

Graduate Texts in Mathematics

听雨尘心@含藏识

GTM 系列电子书下载



Springer 版权所有

仅供学习，请支持正版书籍

<http://realking1980.bokee.com>

Graduate Texts in Mathematics

William S. Massey

**A Basic Course
in Algebraic
Topology**

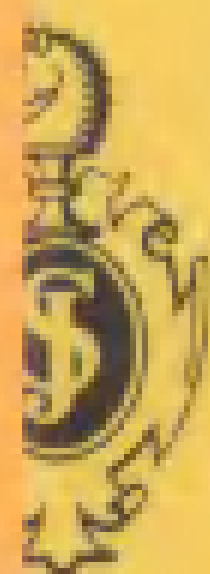

Springer-Verlag

William S. Massey

A Basic Course in Algebraic Topology

With 57 Illustrations in 91 Parts



Springer-Verlag
New York Berlin Heidelberg London
Paris Tokyo Hong Kong Barcelona

William S. Massey
Department of Mathematics
Yale University
New Haven, Connecticut 06520

Editorial Board:

John H. Ewing
Department of Mathematics
Indiana University
Bloomington, Indiana 47405

F.W. Gehring
Department of Mathematics
University of Michigan
Ann Arbor, Michigan 48109

Paul R. Halmos
Department of Mathematics
Santa Clara University
Santa Clara, California 95053

Library of Congress Cataloging-in-Publication Data
Massey, William S.

A basic course in algebraic topology / William S. Massey.

p. cm.—(Graduate texts in mathematics; 127)

Includes bibliographical references and index.

ISBN 0-387-97430-X (alk. paper)

1. Algebraic topology. I. Title. II. Series.

QA612.M374 1991

514'.2—dc20

90-46073

CIP

Printed on acid-free paper.

© 1991 Springer-Verlag New York Inc.

This book is a new edition of the first five chapters of *Algebraic Topology: An Introduction* (GTM 56) and essentially all of *Singular Homology Theory* (GTM 70) by William S. Massey.

All rights reserved. This work may not be translated or copied in whole or in part without the written permission of the publisher (Springer-Verlag New York, Inc., 175 Fifth Avenue, New York, NY 10010, USA), except for brief excerpts in connection with reviews or scholarly analysis. Use in connection with any form of information and retrieval, electronic adaptation, computer computer software, or by similar or dissimilar methodology now known or hereafter developed is forbidden.

The use of general descriptive names, trade names, trademarks, etc., in this publication, even if the former are not especially identified, is not to be taken as a sign that such names, as understood by the Trade Marks and Merchandise Marks Act, may accordingly be used freely by anyone.

Typeset by Asco Trade Typesetting Ltd., Hong Kong.

Printed and bound by R.R. Donnelley and Sons, Harrisonburg, Virginia.

Printed in the United States of America.

9 8 7 6 5 4 3 2 1

ISBN 0-387-97430-X Springer-Verlag New York Berlin Heidelberg

ISBN 3-540-97430-X Springer Verlag Berlin Heidelberg New York

Preface

This book is intended to serve as a textbook for a course in algebraic topology at the beginning graduate level. The main topics covered are the classification of compact 2-manifolds, the fundamental group, covering spaces, singular homology theory, and singular cohomology theory (including cup products and the duality theorems of Poincaré and Alexander). It consists of material from the first five chapters of the author's earlier book *Algebraic Topology: An Introduction* (GTM 56) together with almost all of his book *Singular Homology Theory* (GTM 70). This material from the two earlier books has been revised, corrected, and brought up to date. There is enough here for a full-year course.

The author has tried to give a straightforward treatment of the subject matter, stripped of all unnecessary definitions, terminology, and technical machinery. He has also tried, wherever feasible, to emphasize the geometric motivation behind the various concepts. Several applications of the methods of algebraic topology to concrete geometrical–topological problems are given (e.g., Brouwer fixed point theorem, Brouwer–Jordan separation theorem, Invariance of Domain, Borsuk–Ulam theorem).

In the minds of some people, algebraic topology is a subject which is “esoteric, specialized, and disjoint from the overall sweep of mathematical thought.” It is the author's fervent hope that the emphasis on the geometric motivation for the various concepts, together with the examples of the applications of the subject will help to dispel this point of view.

The concepts and methods which are introduced are developed to the point where they can actually be used to solve problems. For example, after defining the fundamental group, the Seifert–Van Kampen theorem is introduced and explained. This is the principal tool available for actually determining the structure of the fundamental group of various spaces. Another such example

is the cup product. Not only is the cup product defined and its principal properties explained; cup products are actually determined in real, complex, and quaternionic projective spaces, and these computations are then applied to prove certain theorems.

In any exposition of a subject such as algebraic topology, the author has to make choices at various stages. One such choice concerns the class of spaces which will be emphasized. We have preferred to emphasize CW-complexes rather than simplicial complexes. Another choice occurs in the actual definition of singular homology groups: Should one use singular simplices or singular cubes? From a strictly logical point of view it does not matter because the resulting homology and cohomology theories are isomorphic in all respects. From a pedagogical point of view, it does make a difference, however. In developing some of the basic properties of homology theory, such as the homotopy property and the excision property, it is easier and quicker to use the cubical theory. For that reason, we have chosen to use the cubical theory. Of course, it is more traditional to use the simplicial theory; the author hopes that possible prospective users of this book will not reject it because of their respect for tradition alone.

The prospective user of this book can gain some idea of the material contained in each chapter by glancing at the Contents. We are now going to offer additional comments on some of the chapters.

In Chapter I, the classification theorem for compact 2-manifolds is discussed and explained. The proof of the theorem is by rather standard “cut and paste” methods. While this chapter may not be *logically* necessary for the rest of the book, it should not be skipped entirely because 2-manifolds provide a rich source of examples throughout the book.

The general idea of a “universal mapping problem” is a unifying theme in Chapters III and IV. In Chapter III this idea is used in the definition of free groups and free products of groups. Students who are familiar with these concepts can skip this chapter. In Chapter IV the Seifert–Van Kampen theorem on the fundamental group of the union of two spaces is stated in terms of the solution to a certain universal mapping problem. Various special cases and examples are discussed in some detail.

The discussion of homology theory starts in Chapter VI, which contains a summary of some of the basic properties of homology groups, and a survey of some of the problems which originally motivated the development of homology theory. While this chapter is not a prerequisite for the following chapters from a strictly logical point of view, it should be extremely helpful to students who are new to the subject.

Chapters VII, VIII, and IX are concerned solely with singular homology with integer coefficients, perhaps the most basic aspect of the subject. Chapter VIII gives various examples and applications of homology theory, including a proof of the general Jordan–Brouwer separation theorem, and Brouwer’s theorem on “Invariance of Domain.” Chapter IX explains a systematic method of computing the integral homology groups of a regular CW-complex.

In Chapter X we introduce homology with arbitrary coefficient groups. This generalization is carried out by a systematic use of tensor products. Tensor products also play a significant role in Chapter XI, which is concerned with the homology groups of a product space, i.e., the Künneth theorem and the Eilenberg–Zilber theorem.

Cohomology groups make their first appearance in Chapter XII. Much of this chapter of necessity depends on a systematic use of the Hom functor. However, there is also a discussion of the geometric interpretation of cochains and cocycles, a subject which is usually neglected. Chapter XIII contains a systematic discussion of the various products: cup product, cap product, cross product, etc. The cap product is used in Chapter XIV for the statement and proof of the Poincaré duality theorem for manifolds. This chapter also contains the famous Alexander duality theorem and the Lefschetz–Poincaré duality theorem for manifolds with boundary. In Chapter XV we determine cup products in real, complex, and quaternionic projective spaces. These products are then used to prove the classical Borsuk–Ulam theorem, and to give a discussion of the Hopf Invariant of a map of a $(2n - 1)$ -sphere onto an n -sphere.

The book ends with two appendices. Appendix A is devoted to a proof of the famous theorem of DeRham, and Appendix B summarizes various basic facts about permutation groups which are needed in Chapter V on covering spaces.

At the end of many chapters there are notes which give further comments on the subject matter, hints of more recent developments, or a brief history of some of the ideas.

As mentioned above, there is enough material in this book for a full-year course in algebraic topology. For a shorter course, Chapters I–VIII would give a good introduction to many of the basic ideas. Another possibility for a shorter course would be to use Chapter I, skip Chapters II through V, and then take as many chapters after Chapter V as time permits. The author has tried both of these shorter programs several times with good results.

Prerequisites

As in any book on algebraic topology, a knowledge of the basic facts of point set topology is necessary. The reader should feel comfortable with such notions as continuity, compactness, connectedness, homeomorphism, product space, etc. From time to time we have found it necessary to make use of the quotient space or identification space topology; this subject is discussed in the more comprehensive textbooks on point set topology.

The amount of algebra the reader will need depends on how far along he is in the book; in general, the farther he goes, the more algebraic knowledge will be necessary. For Chapters II through V, only a basic, general knowledge of group theory is necessary. Here the reader must understand such terms as

group, subgroup, normal subgroup, homomorphism, quotient group, coset, abelian group, and cyclic group. Moreover, it is hoped that he has seen enough examples and worked enough exercises to have some feeling for the true significance of these concepts. Most of the additional topics needed in group theory are developed in Chapter III and in Appendix B. Most of the groups which occur in these chapters are written multiplicatively.

From Chapter VI to the end of the book, most of the groups which occur are abelian and are written additively. It would be desirable if the reader were familiar with the structure theorem for finitely generated abelian groups (see Theorem V.3.6). Starting in Chapter X, the tensor product of abelian groups is used; and from Chapter XII on the Hom functor is used. Also needed in a few places are the first derived functors of tensor product and Hom (the functors Tor and Ext). These functors are described in detail in books on homological algebra and various other texts. At the appropriate places we give complete references and a summary of their basic properties. In these later chapters we also use some of the language of category theory for the sake of convenience; however, no results or theorems of category theory are used. In order to read Appendix A the reader must be familiar with differential forms and differentiable manifolds.

Acknowledgments

The author is grateful to many colleagues, friends, and students for their suggestions and for the corrections of misprints and mistakes in his earlier two books in this series. The secretarial staff of the Yale Mathematics Department has also played an essential role, and the author is extremely grateful to them. Finally, thanks are due to the staff of Springer-Verlag New York for their kind help in the production of this and the author's previous books.

William S. Massey
New Haven, Connecticut
March, 1988

Contents

Preface	v
Notation and Terminology	xv
CHAPTER I	
Two-Dimensional Manifolds	1
§1. Introduction	1
§2. Definition and Examples of n -Manifolds	2
§3. Orientable vs. Nonorientable Manifolds	3
§4. Examples of Compact, Connected 2-Manifolds	5
§5. Statement of the Classification Theorem for Compact Surfaces	9
§6. Triangulations of Compact Surfaces	14
§7. Proof of Theorem 5.1	16
§8. The Euler Characteristic of a Surface	26
References	34
CHAPTER II	
The Fundamental Group	35
§1. Introduction	35
§2. Basic Notation and Terminology	36
§3. Definition of the Fundamental Group of a Space	38
§4. The Effect of a Continuous Mapping on the Fundamental Group	42
§5. The Fundamental Group of a Circle Is Infinite Cyclic	47

§6. Application: The Brouwer Fixed-Point Theorem in Dimension 2	50
§7. The Fundamental Group of a Product Space	52
§8. Homotopy Type and Homotopy Equivalence of Spaces	54
References	59

CHAPTER III

Free Groups and Free Products of Groups **60**

§1. Introduction	60
§2. The Weak Product of Abelian Groups	60
§3. Free Abelian Groups	63
§4. Free Products of Groups	71
§5. Free Groups	75
§6. The Presentation of Groups by Generators and Relations	78
§7. Universal Mapping Problems	81
References	85

CHAPTER IV

Seifert and Van Kampen Theorem on the Fundamental Group of the Union of Two Spaces. Applications **86**

§1. Introduction	86
§2. Statement and Proof of the Theorem of Seifert and Van Kampen	87
§3. First Application of Theorem 2.1	91
§4. Second Application of Theorem 2.1	95
§5. Structure of the Fundamental Group of a Compact Surface	96
§6. Application to Knot Theory	103
§7. Proof of Lemma 2.4	108
References	116

CHAPTER V

Covering Spaces **117**

§1. Introduction	117
§2. Definition and Some Examples of Covering Spaces	117
§3. Lifting of Paths to a Covering Space	123
§4. The Fundamental Group of a Covering Space	126
§5. Lifting of Arbitrary Maps to a Covering Space	127
§6. Homomorphisms and Automorphisms of Covering Spaces	130

§7. The Action of the Group $\pi(X, x)$ on the Set $p^{-1}(x)$	133
§8. Regular Covering Spaces and Quotient Spaces	135
§9. Application: The Borsuk–Ulam Theorem for the 2-Sphere	138
§10. The Existence Theorem for Covering Spaces	140
References	146

CHAPTER VI

Background and Motivation for Homology Theory **147**

§1. Introduction	147
§2. Summary of Some of the Basic Properties of Homology Theory	147
§3. Some Examples of Problems which Motivated the Development of Homology Theory in the Nineteenth Century	149
References	157

CHAPTER VII

Definitions and Basic Properties of Homology Theory **158**

§1. Introduction	158
§2. Definition of Cubical Singular Homology Groups	158
§3. The Homomorphism Induced by a Continuous Map	163
§4. The Homotopy Property of the Induced Homomorphisms	166
§5. The Exact Homology Sequence of a Pair	169
§6. The Main Properties of Relative Homology Groups	173
§7. The Subdivision of Singular Cubes and the Proof of Theorem 6.4	178

CHAPTER VIII

**Determination of the Homology Groups of Certain Spaces:
Applications and Further Properties of Homology Theory** **186**

§1. Introduction	186
§2. Homology Groups of Cells and Spheres—Applications	192
§3. Homology of Finite Graphs	201
§4. Homology of Compact Surfaces	206
§5. The Mayer–Vietoris Exact Sequence	207
§6. The Jordan–Brouwer Separation Theorem and Invariance of Domain	211
§7. The Relation between the Fundamental Group and the First Homology Group	217
References	224

CHAPTER IX

Homology of CW-Complexes **225**

§1. Introduction	225
§2. Adjoining Cells to a Space	225
§3. CW-Complexes	228
§4. The Homology Groups of a CW-Complex	232
§5. Incidence Numbers and Orientations of Cells	238
§6. Regular CW-Complexes	243
§7. Determination of Incidence Numbers for a Regular Cell Complex	244
§8. Homology Groups of a Pseudomanifold	249
References	253

CHAPTER X

Homology with Arbitrary Coefficient Groups **254**

§1. Introduction	254
§2. Chain Complexes	254
§3. Definition and Basic Properties of Homology with Arbitrary Coefficients	262
§4. Intuitive Geometric Picture of a Cycle with Coefficients in G	266
§5. Coefficient Homomorphisms and Coefficient Exact Sequences	267
§6. The Universal Coefficient Theorem	269
§7. Further Properties of Homology with Arbitrary Coefficients	274
References	278

CHAPTER XI

The Homology of Product Spaces **279**

§1. Introduction	279
§2. The Product of CW-Complexes and the Tensor Product of Chain Complexes	280
§3. The Singular Chain Complex of a Product Space	282
§4. The Homology of the Tensor Product of Chain Complexes (The Künneth Theorem)	284
§5. Proof of the Eilenberg–Zilber Theorem	286
§6. Formulas for the Homology Groups of Product Spaces	300
References	303

CHAPTER XII

Cohomology Theory 305

§1. Introduction	305
§2. Definition of Cohomology Groups—Proofs of the Basic Properties	306
§3. Coefficient Homomorphisms and the Bockstein Operator in Cohomology	309
§4. The Universal Coefficient Theorem for Cohomology Groups	310
§5. Geometric Interpretation of Cochains, Cocycles, etc.	316
§6. Proof of the Excision Property; the Mayer–Vietoris Sequence	319
References	322

CHAPTER XIII

Products in Homology and Cohomology 323

§1. Introduction	323
§2. The Inner Product	324
§3. An Overall View of the Various Products	324
§4. Extension of the Definition of the Various Products to Relative Homology and Cohomology Groups	329
§5. Associativity, Commutativity, and Existence of a Unit of the Various Products	333
§6. Digression: The Exact Sequence of a Triple or a Triad	336
§7. Behavior of Products with Respect to the Boundary and Coboundary Operator of a Pair	338
§8. Relations Involving the Inner Product	341
§9. Cup and Cap Products in a Product Space	342
§10. Remarks on the Coefficients for the Various Products— The Cohomology Ring	343
§11. The Cohomology of Product Spaces (The Künneth Theorem for Cohomology)	344
References	349

CHAPTER XIV

Duality Theorems for the Homology of Manifolds 350

§1. Introduction	350
§2. Orientability and the Existence of Orientations for Manifolds	351
§3. Cohomology with Compact Supports	358
§4. Statement and Proof of the Poincaré Duality Theorem	360

§5. Applications of the Poincaré Duality Theorem to Compact Manifolds	365
§6. The Alexander Duality Theorem	370
§7. Duality Theorems for Manifolds with Boundary	375
§8. Appendix: Proof of Two Lemmas about Cap Products	380
References	393
CHAPTER XV	
Cup Products in Projective Spaces and Applications of Cup Products	394
§1. Introduction	394
§2. The Projective Spaces	394
§3. The Mapping Cylinder and Mapping Cone	399
§4. The Hopf Invariant	402
References	406
APPENDIX A	
A Proof of De Rham's Theorem	407
§1. Introduction	407
§2. Differentiable Singular Chains	408
§3. Statement and Proof of De Rham's Theorem	411
References	417
APPENDIX B	
Permutation Groups or Transformation Groups	419
§1. Basic Definitions	419
§2. Homogeneous G -spaces	421
Index	424

Notation and Terminology

The standard language and notation of set theory is used throughout. Some more special notations that are used in this book are the following:

- \mathbf{Z} = ring of integers,
- \mathbf{Q} = field of all rational numbers,
- \mathbf{R} = field of all real numbers,
- \mathbf{C} = field of all complex numbers,
- \mathbf{R}^n = set of all n -tuples (x_1, \dots, x_n) of real numbers,
- \mathbf{C}^n = set of all n -tuples of complex numbers.

If $x = (x_1, \dots, x_n) \in \mathbf{R}^n$, then the *norm* or *absolute value* of x is

$$|x| = (x_1^2 + x_2^2 + \dots + x_n^2)^{1/2}.$$

With this notation, we define the following standard subsets of \mathbf{R}^n for any $n > 0$:

$$\begin{aligned} E^n &= \{x \in \mathbf{R}^n \mid |x| \leq 1\}, \\ U^n &= \{x \in \mathbf{R}^n \mid |x| < 1\}, \\ S^{n-1} &= \{x \in \mathbf{R}^n \mid |x| = 1\}. \end{aligned}$$

These spaces are called the *closed n -dimensional disc* or *ball*, the *open n -dimensional disc* or *ball*, and the *$(n - 1)$ -dimensional sphere*, respectively. Each is topologized as a subset of Euclidean n -space, \mathbf{R}^n . The symbols RP^n , CP^n , and QP^n are introduced in Chapter IX to denote n -dimensional real, complex, and quaternionic projective space, respectively.

A homomorphism from one group to another is called an *epimorphism* if it is onto, a *monomorphism* if it is one-to-one (i.e., the kernel consists of a single element) and an *isomorphism* if it is both one-to-one and onto. If $h : A \rightarrow B$ is

a homomorphism of abelian groups, the *cokernel* of h is the quotient group $B/h(A)$. A sequence of groups and homomorphisms such as

$$\cdots \longrightarrow A_{n-1} \xrightarrow{h_{n-1}} A_n \xrightarrow{h_n} A_{n+1} \longrightarrow \cdots$$

is called *exact* if the kernel of each homomorphism is precisely the same as the image of the preceding homomorphism. Such exact sequences play a big role from Chapter VII on.

CHAPTER I

Two-Dimensional Manifolds

§1. Introduction

The topological concept of a surface or 2-dimensional manifold is a mathematical abstraction of the familiar concept of a surface made of paper, sheet metal, plastic, or some other thin material. A surface or 2-dimensional manifold is a topological space with the same local properties as the familiar plane of Euclidean geometry. An intelligent bug crawling on a surface could not distinguish it from a plane if he had a limited range of visibility.

The natural, higher-dimensional analog of a surface is an n -dimensional manifold, which is a topological space with the same local properties as Euclidean n -space. Because they occur frequently and have application in many other branches of mathematics, manifolds are certainly one of the most important classes of topological spaces. Although we define and give some examples of n -dimensional manifolds for any positive integer n , we devote most of this chapter to the case $n = 2$. Because there is a classification theorem for compact 2-manifolds, our knowledge of 2-dimensional manifolds is incomparably more complete than our knowledge of the higher-dimensional cases. This classification theorem gives a simple procedure for obtaining all possible compact 2-manifolds. Moreover, there are simple computable invariants which enable us to decide whether or not any two compact 2-manifolds are homeomorphic. This may be considered an ideal theorem. Much research in topology has been directed toward the development of analogous classification theorems for other situations. Unfortunately, no such theorem is known for compact 3-manifolds, and logicians have shown that we cannot even hope for such a complete result for n -manifolds, $n \geq 4$. Nevertheless, the theory of higher-dimensional manifolds is currently a very

active field of mathematical research and will probably continue to be so for a long time to come.

We shall use the material developed in this chapter later in the book.

§2. Definition and Examples of n -Manifolds

Assume n is a positive integer. An n -dimensional manifold is a Hausdorff space (i.e., a space that satisfies the T_2 separation axiom) such that each point has an open neighborhood homeomorphic to the open n -dimensional disc U^n ($= \{x \in \mathbf{R}^n : |x| < 1\}$). Usually we shall say “ n -manifold” for short.

Examples

2.1. Euclidean n -space \mathbf{R}^n is obviously an n -dimensional manifold. We can easily prove that the unit n -dimensional sphere

$$S^n = \{x \in \mathbf{R}^{n+1} : |x| = 1\}$$

is an n -manifold. For the point $x = (1, 0, \dots, 0)$, the set $\{(x_1, \dots, x_{n+1}) \in S^n : x_1 > 0\}$ is a neighborhood with the required properties, as we see by orthogonal projection on the hyperplane in \mathbf{R}^{n+1} defined by $x_1 = 0$. For any other point $x \in S^n$, there is a rotation carrying x into the point $(1, 0, \dots, 0)$. Such a rotation is a homeomorphism of S^n onto itself; hence, x also has the required kind of neighborhood.

2.2. If M^n is any n -dimensional manifold, then any open subset of M^n is also an n -dimensional manifold. The proof is immediate.

2.3. If M is an m -dimensional manifold and N is an n -dimensional manifold, then the product space $M \times N$ is an $(m + n)$ -dimensional manifold. This follows from the fact that $U^m \times U^n$ is homeomorphic to U^{m+n} . To prove this, note that, for any positive integer k , U^k is homeomorphic to \mathbf{R}^k , and $\mathbf{R}^m \times \mathbf{R}^n$ is homeomorphic to \mathbf{R}^{m+n} .

In addition to the 2-sphere S^2 , the reader can easily give examples of many other subsets of Euclidean 3-space \mathbf{R}^3 , which are 2-manifolds, e.g., surfaces of revolution, etc.

As these examples show, an n -manifold may be either connected or disconnected, compact or noncompact. In any case, an n -manifold is always locally compact.

What is not so obvious is that a connected manifold need not satisfy the second axiom of countability (i.e., it need not have a countable base). The simplest example is the “long line.”¹ Such manifolds are usually regarded as pathological, and we shall restrict our attention to manifolds with a countable base.

¹ See *General Topology* by J. L. Kelley. Princeton, N.J.: Van Nostrand, 1955. Exercise L, p. 164.

Note that in our definition we required that a manifold satisfy the Hausdorff separation axiom. We must make this requirement explicit in the definition because it is *not* a consequence of the other conditions imposed on a manifold. We leave it to the reader to construct examples of non-Hausdorff spaces, such that each point has an open neighborhood homeomorphic to U^n for $n = 1$ or 2 .

§3. Orientable vs. Nonorientable Manifolds

Connected n -manifolds for $n > 1$ are divided into two kinds: orientable and nonorientable. We will try to make the distinction clear without striving for mathematical precision.

Consider the case where $n = 2$. We can prescribe in various ways an orientation for the Euclidean plane \mathbf{R}^2 or, more generally, for a small region in the plane. For example, we could designate which of the two possible kinds of coordinate systems in the plane is to be considered a right-handed coordinate system and which is to be considered a left-handed coordinate system. Another way would be to prescribe which direction of rotation in the plane about a point is to be considered the positive direction and which is to be considered the negative direction. Let us imagine an intelligent bug or some 2-dimensional being constrained to move in the plane; once he decides on a choice of orientation at any point in the plane, he can carry this choice with him as he moves about. If two such bugs agree on an orientation at a given point in the plane, and one of them travels on a long trip to some distant point in the plane and eventually returns to his starting point, both bugs will still agree on their choice of orientation.

Similar considerations apply to any connected 2-dimensional manifold because each point has a neighborhood homeomorphic to a neighborhood of a point in the plane. Here our two hypothetical bugs agree on a choice of orientation at a given point. It is possible, however, that after one of them returns from a long trip to some distant point on the manifold, they may find they are no longer in agreement. This phenomenon can occur even though both were meticulously careful about keeping an accurate check of the positive orientation.

The simplest example of a 2-dimensional manifold exhibiting this phenomenon is the well-known Möbius strip. As the reader probably knows, we construct a model of a Möbius strip by taking a long, narrow rectangular strip of paper and gluing the ends together with a half twist (see Figure 1.1). Mathematically, a Möbius strip is a topological space that is described as follows. Let X denote the following rectangle in the plane:

$$X = \{(x, y) \in \mathbf{R}^2 : -10 \leq x \leq +10, -1 < y < +1\}.$$

We then form a quotient space of X by identifying the points $(10, y)$ and $(-10, -y)$ for $-1 < y < +1$. Note that the two boundaries of the rectangle

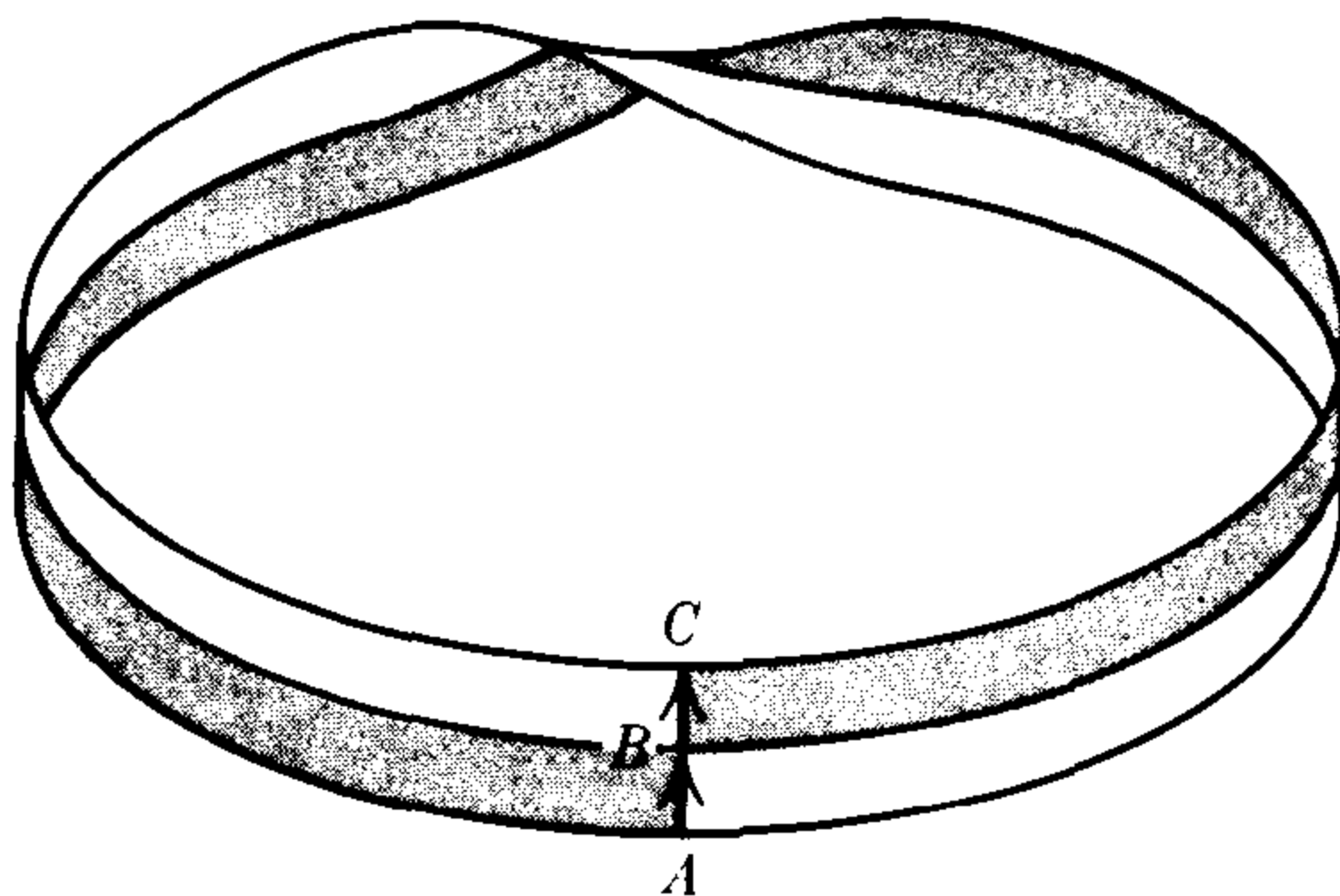
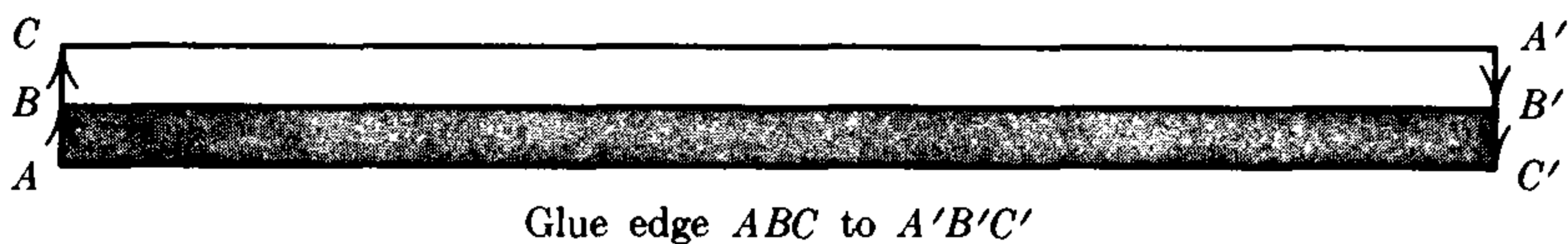

FIGURE 1.1. Constructing a Möbius strip.

corresponding to $y = +1$ and $y = -1$ were omitted. This omission is crucial; otherwise the result would not be a manifold (it would be a “manifold with boundary,” a concept we will take up later in Chapter XIV). Alternatively, we could specify a certain subset of \mathbf{R}^3 which is homeomorphic to the quotient space just described.

However, we define the Möbius strip, the center line of the rectangular strip becomes a circle after the gluing or identification of the two ends. We leave it to the reader to verify that if our imaginary bug started out at any point on this circle with a definite choice of orientation and carried this orientation with him around the circle once, he would come back to his initial point with his original orientation reversed. We will call such a path in a manifold an *orientation-reversing* path. A closed path that does not have this property will be called an *orientation-preserving* path. For example, any closed path in the plane is orientation preserving.

A connected 2-manifold is defined to be *orientable* if every closed path is orientation preserving; a connected 2-manifold is *nonorientable* if there is at least one orientation-reversing path.

We now consider the orientability of 3-manifolds. We can specify an orientation of Euclidean 3-space or a small region thereof by designating which type of coordinate system is to be considered right handed and which type is to be considered left handed. An alternative method would be to specify which type of helix or screw thread is to be designated as right handed and which kind is to be left handed. We can now describe a closed path in a 3-manifold as *orientation preserving* or *orientation reversing*, depending on whether or not a traveler who traverses the path comes back to his initial

point with his initial choice of right and left unchanged. If our universe were nonorientable, then an astronaut who made a journey along some orientation-reversing path would return to earth with the right and left sides of his body interchanged: His heart would not be on the right side of his chest, etc.

There is a 3-dimensional generalization of the Möbius strip which furnishes a particularly simple example of a nonorientable 3-manifold. Let

$$X = \{(x, y, z) \in \mathbf{R}^3 : -10 \leq x \leq +10, -1 < y < +1, -1 < z < +1\}.$$

Form a quotient space of X by identifying the points $(10, y, z)$ and $(-10, -y, z)$ for $-1 < y < +1$ and $-1 < z < +1$. This space may also be considered the product of an ordinary 2-dimensional Möbius strip with the open interval $\{z \in \mathbf{R} : -1 < z < +1\}$. In any case, the segment $-10 \leq x \leq +10$ of the x axis becomes a circle under the identification, and we leave it to the reader to convince himself that this circle is an orientation-reversing path in the resulting 3-manifold.

We will consider the analogous definitions for higher-dimensional manifolds in later chapters.

§4. Examples of Compact, Connected 2-Manifolds

To save words, from now on we shall refer to a connected 2-manifold as a *surface*. The simplest example of a compact surface is the 2-sphere S^2 ; another important example is the *torus*. A torus may be roughly described as any surface homeomorphic to the surface of a doughnut or of a solid ring. It may be defined more precisely as

- (a) Any topological space homeomorphic to the product of two circles, $S^1 \times S^1$.
- (b) Any topological space homeomorphic to the following subset of \mathbf{R}^3 :

$$\{(x, y, z) \in \mathbf{R}^3 : [(x^2 + y^2)^{1/2} - 2]^2 + z^2 = 1\}.$$

[This is the set obtained by rotating the circle $(x - 2)^2 + z^2 = 1$ in the xz plane about the z axis.]

- (c) Let X denote the unit square in the plane \mathbf{R}^2 :

$$\{(x, y) \in \mathbf{R}^2 : 0 \leq x \leq 1, 0 \leq y \leq 1\}.$$

Then, a torus is any space homeomorphic to the quotient space of X obtained by identifying opposite sides of the square X according to the following rules. The points $(0, y)$ and $(1, y)$ are to be identified for $0 \leq y \leq 1$, and the points $(x, 0)$ and $(x, 1)$ are to be identified for $0 \leq x \leq 1$.

We will find it convenient to indicate symbolically how such identifications are to be made by a diagram such as Figure 1.2. Sides that are to be identified are labeled with the same letter of the alphabet, and the identifications should be made so that the directions indicated by the arrows agree.

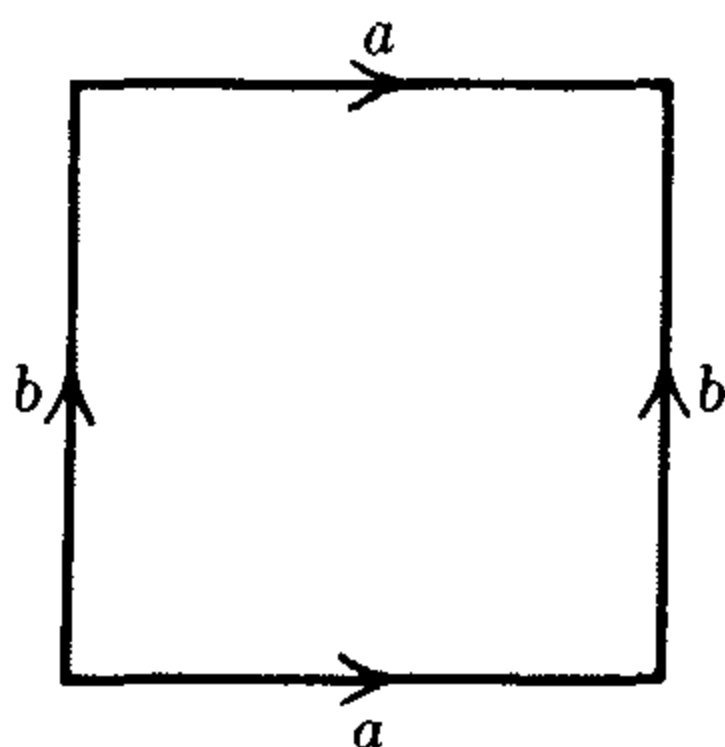

FIGURE 1.2. Construction of a torus.

We leave it to the reader to prove that the topological spaces described in (a), (b), and (c) are actually homeomorphic. The reader should also convince himself that a torus is orientable.

Our next example of a compact surface is the *real projective plane* (referred to as the *projective plane* for short). It is a compact, nonorientable surface. Because it is not homeomorphic to any subset of Euclidean 3-space, the projective plane is much more difficult to visualize than the 2-sphere or the torus.

Definition. The quotient space of the 2-sphere S^2 obtained by identifying every pair of diametrically opposite points is called a *projective plane*. We shall also refer to any space homeomorphic to this quotient space as a projective plane.

For readers who have studied projective geometry, we shall explain why this surface is called the real projective plane. Such a reader will recall that, in the study of projective plane geometry, a point has “homogeneous” coordinates (x_0, x_1, x_2) , where $x_0, x_1,$ and x_2 are real numbers, at least one of which is $\neq 0$. The term “homogeneous” means (x_0, x_1, x_2) and (x'_0, x'_1, x'_2) represent the same point if and only if there exists a real number λ (of necessity $\neq 0$) such that

$$x_i = \lambda x'_i, \quad i = 0, 1, 2.$$

If we interpret (x_0, x_1, x_2) as the ordinary Euclidean coordinates of a point in \mathbf{R}^3 , then we see that (x_0, x_1, x_2) and (x'_0, x'_1, x'_2) represent the same point in the projective plane if and only if they are on the same line through the origin. Thus, we may reinterpret a point of the projective plane as a line through the origin in \mathbf{R}^3 . The next question is, how shall we topologize the set of all lines through the origin in \mathbf{R}^3 ? Perhaps the easiest way is to note that each line through the origin in \mathbf{R}^3 intersects the unit sphere S^2 in a pair of diametrically opposite points. This leads to the above definition.

Let $H = \{(x, y, z) \in S^2 : z \geq 0\}$ denote the closed upper hemisphere of S^2 . It is clear that, of each diametrically opposite pair of points in S^2 , at least one point lies in H . If both points lie in H , then they are on the equator, which is

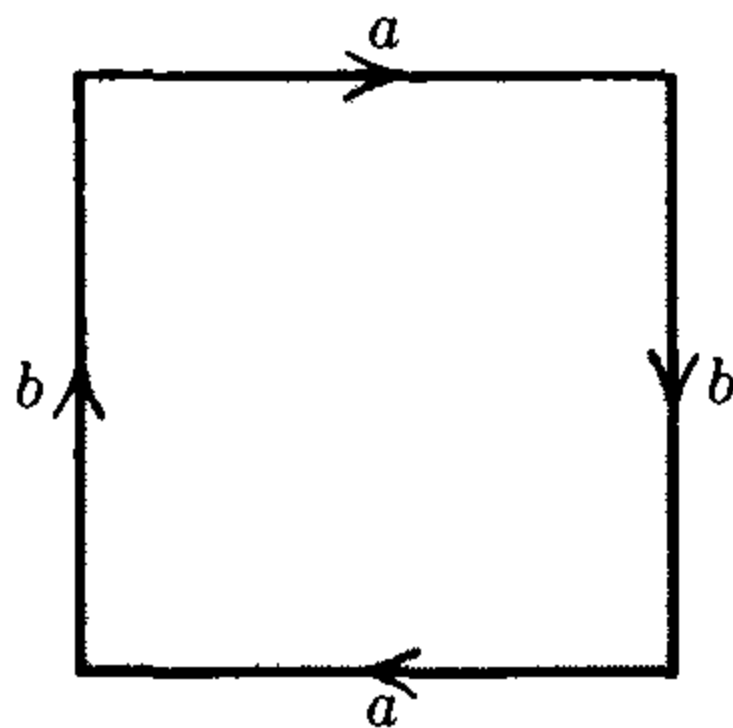

FIGURE 1.3. Construction of a projective plane from a square.

the boundary of H . Thus, we could also define the projective plane as the quotient space of H obtained by identifying diametrically opposite points on the boundary of H . As H is obviously homeomorphic to the closed unit disc E^2 in the plane,

$$E^2 = \{(x, y) \in \mathbf{R}^2 : x^2 + y^2 \leq 1\},$$

the quotient space of E^2 obtained by identifying diametrically opposite points on the boundary is a projective plane. For E^2 we could substitute any homeomorphic space, e.g., a square. Thus, a projective plane is obtained by identifying the opposite sides of a square as indicated in Figure 1.3. The reader should compare this with the construction of a torus in Figure 1.2.

The projective plane is easily seen to be nonorientable; in fact, it contains a subset homeomorphic to a Möbius strip.

We shall now describe how to give many additional examples of compact surfaces by forming what are called connected sums. Let S_1 and S_2 be disjoint surfaces. Their *connected sum*, denoted by $S_1 \# S_2$, is formed by cutting a small circular hole in each surface, and then gluing the two surfaces together along the boundaries of the holes. To be precise, we choose subsets $D_1 \subset S_1$ and $D_2 \subset S_2$ such that D_1 and D_2 are closed discs (i.e., homeomorphic to E^2). Let S'_i denote the complement of the interior of D_i in S_i for $i = 1$ and 2 . Choose a homeomorphism h of the boundary circle of D_1 onto the boundary of D_2 . Then $S_1 \# S_2$ is the quotient space of $S'_1 \cup S'_2$ obtained by identifying the points x and $h(x)$ for all points x in the boundary of D_1 . It is clear that $S_1 \# S_2$ is a surface. It seems plausible, and can be proved rigorously, that the topological type of $S_1 \# S_2$ does not depend on the choice of the discs D_1 and D_2 or the choice of the homeomorphism h .

Examples

4.1. If S_2 is a 2-sphere, then $S_1 \# S_2$ is homeomorphic to S_1 .

4.2. If S_1 and S_2 are both tori, then $S_1 \# S_2$ is homeomorphic to the surface of a block that has two holes drilled through it. (It is assumed, of course, that the holes are not so close together that their boundaries touch or intersect.)

4.3. If S_1 and S_2 are projective planes, then $S^1 \# S^2$ is a “Klein bottle,” i.e., homeomorphic to the surface obtained by identifying the opposite sides of a

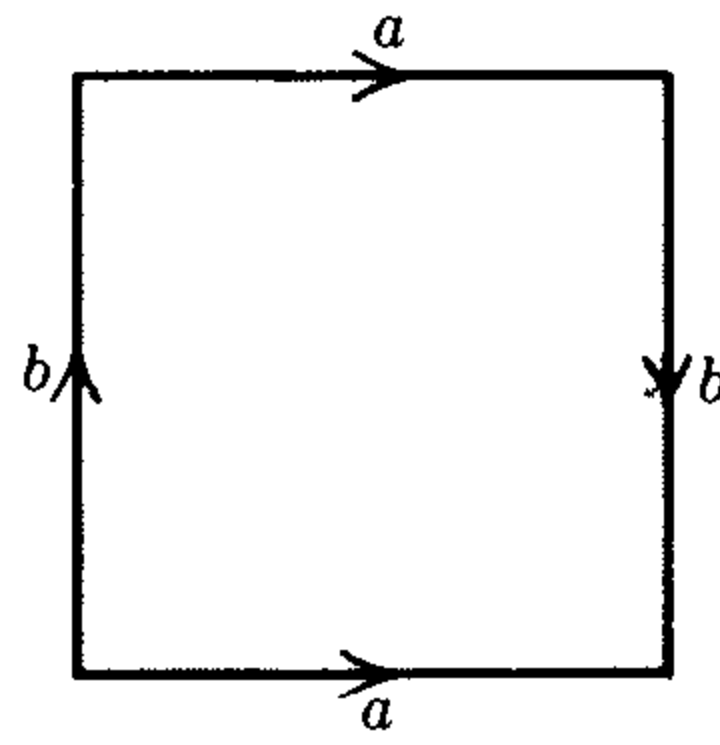

FIGURE 1.4. Construction of a Klein bottle from a square.

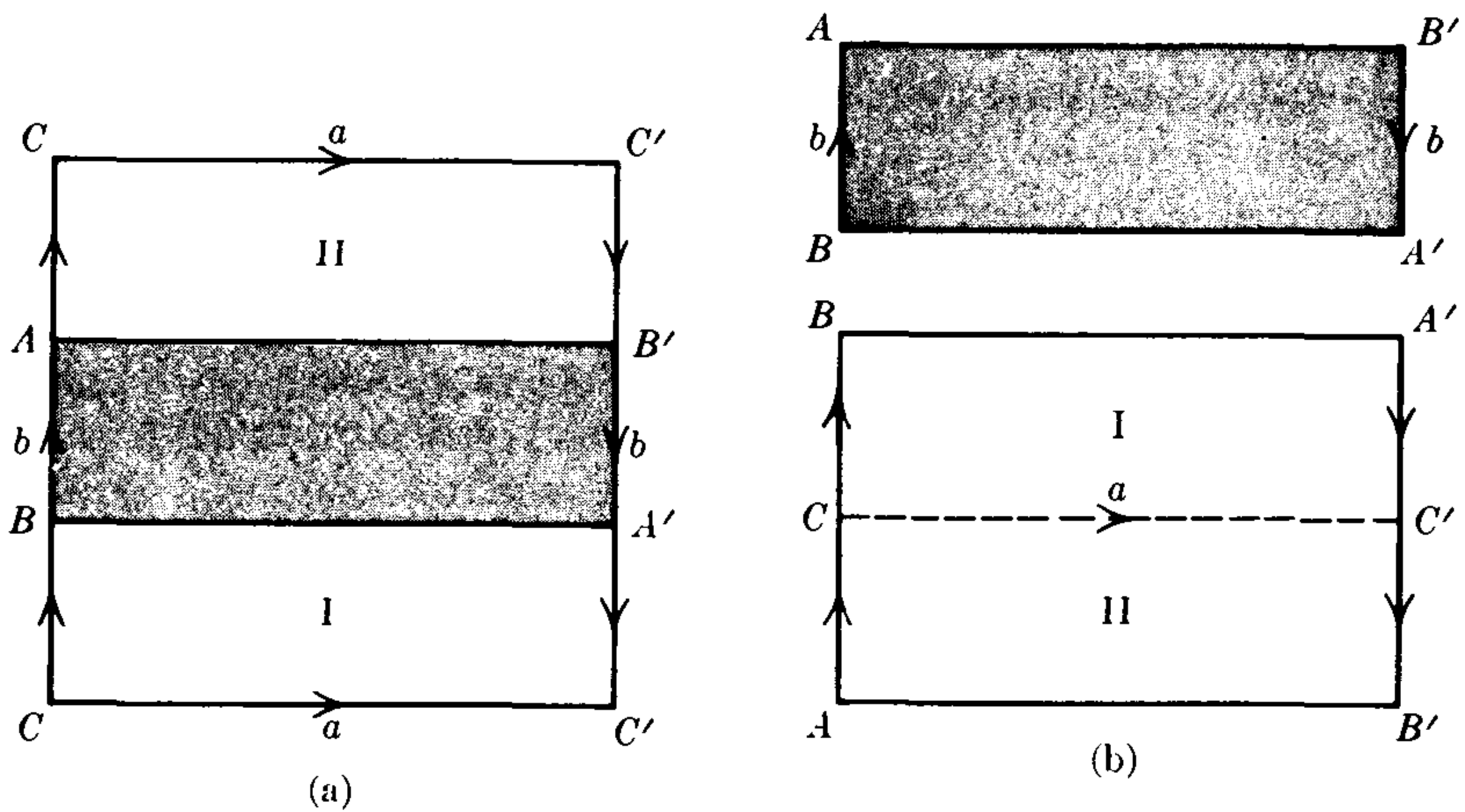

FIGURE 1.5. The Klein bottle is the union of two Möbius strips.

square as shown in Figure 1.4. We may prove this by the “cut and paste” technique, as follows. If S_i is a projective plane and D_i is a closed disc such that $D_i \subset S_i$, then S_i' , the complement of the interior of D_i , is homeomorphic to a Möbius strip (including the boundary). In fact, if we think of S_i as the space obtained by identification of the diametrically opposite points on the boundary of the unit disc E^2 in \mathbf{R}^2 , then we can choose D_i to be the image of the set $\{(x, y) \in E^2 : |y| \geq \frac{1}{2}\}$ under the identification, and the truth of the assertion is clear. From this it follows that $S_1 \# S_2$ is obtained by gluing together two Möbius strips along their boundaries. On the other hand, Figure 1.5 shows how to cut a Klein bottle so as to obtain two Möbius strips. We cut along the lines AB' and BA' ; under the identification, this cut becomes a circle.

We will now consider some properties of this operation of forming connected sums.

It is clear from our definitions that there is no distinction between $S_1 \# S_2$ and $S_2 \# S_1$; i.e., the operation is commutative. It is not difficult to see that

the manifolds $(S_1 \# S_2) \# S_3$ and $S_1 \# (S_2 \# S_3)$ are homeomorphic. Thus, we see that the connected sum is a commutative, associative operation on the set of homeomorphism types of compact surfaces. Moreover, Example 4.1 shows the sphere is a unit or neutral element for this operation. We must not jump to the conclusion that the set of homeomorphism classes of compact surfaces forms a group under this operation: There are no inverses. It only forms what is called a semigroup.

The connected sum of two orientable manifolds is again orientable. On the other hand, if either S_1 or S_2 is nonorientable, then so is $S_1 \# S_2$.

§5. Statement of the Classification Theorem for Compact Surfaces

In the preceding section we have seen how examples of compact surfaces can be constructed by forming connected sums of various numbers of tori and/or projective planes. Our main theorem asserts that these examples exhaust all the possibilities. In fact, it is even a slightly stronger statement, in that we do not need to consider surfaces that are connected sums of both tori and projective planes.

Theorem 5.1. *Any compact surface is either homeomorphic to a sphere, or to a connected sum of tori, or to a connected sum of projective planes.*

As preparation for the proof, we shall describe what might be called a “canonical form” for a connected sum of tori or projective planes.

Recall our description of a torus as a square with the opposite sides identified (see Figure 1.2). We can obtain an analogous description of the connected sum of two tori as follows. Represent each of the tori T_1 and T_2 as a square with opposite sides identified as shown in Figure 1.6(a). Note that all four vertices of each square are identified to a single point of the corresponding torus. To form their connected sum, we must first cut out a circular hole in each torus, and we can do this in any way that we wish. It is convenient to cut out the regions shaded in the diagrams. The boundaries of the holes are labeled c_1 and c_2 , and they are to be identified as indicated by the arrows. We can also represent the complement of the holes in the two tori by the pentagons shown in Figure 1.6(b), because the indicated edge identifications imply that the two end points of the segment c_i are to be identified, $i = 1, 2$. We now identify the segments c_1 and c_2 ; the result is the octagon in Figure 1.6(c), in which the sides are to be identified in pairs, as indicated. Note that all eight vertices of this octagon are to be identified to a single point in $T_1 \# T_2$.

This octagon with the edges identified in pairs is our desired “canonical form” for the connected sum of two tori. By repeating this process, we can show that the connected sum of three tori is the quotient space of the 12-gon

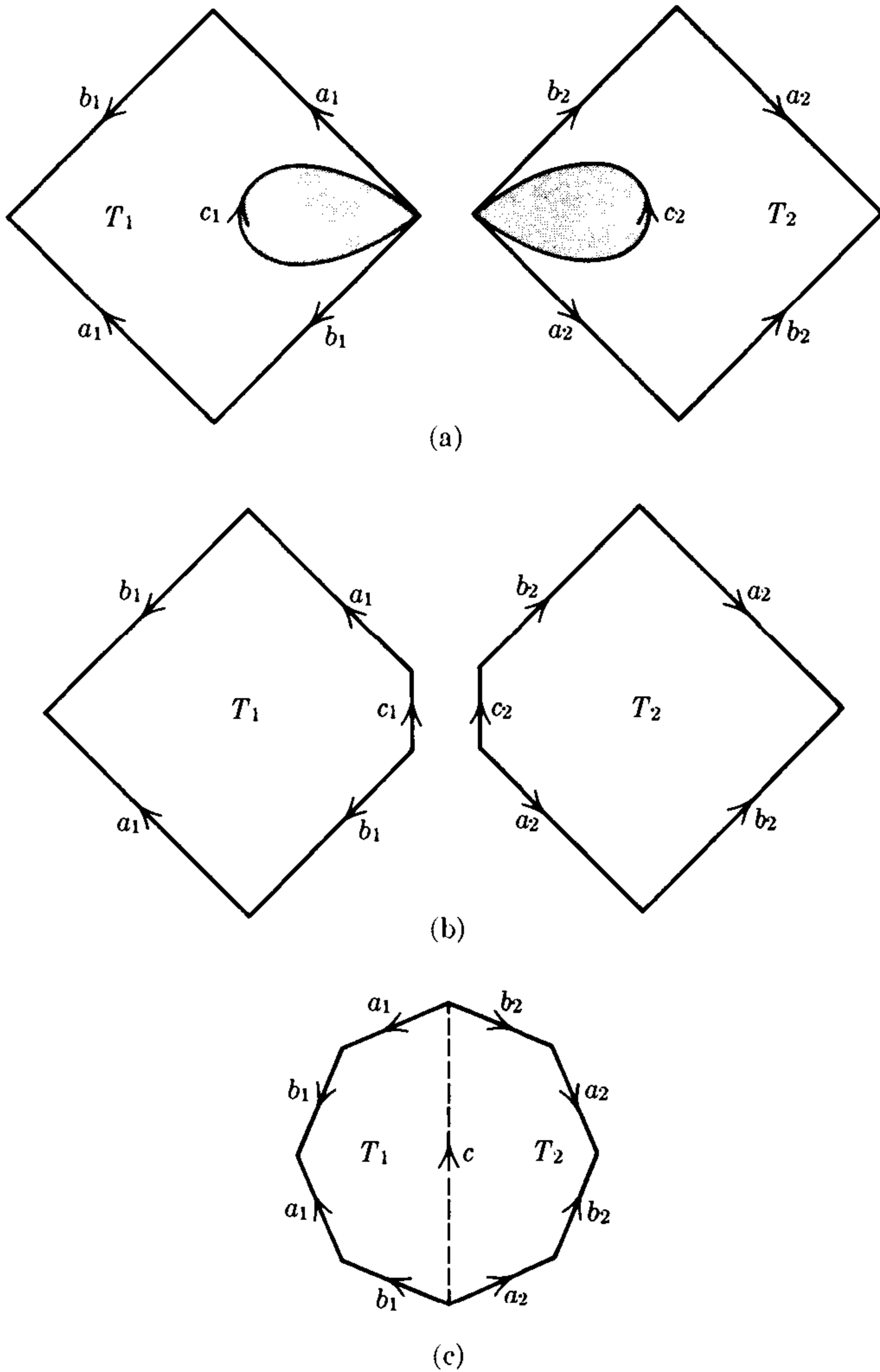

FIGURE 1.6. (a) Two disjoint tori, T_1 and T_2 . (b) Disjoint tori with holes cut out. (c) After gluing together.

shown in Figure 1.7, where the edges are to be identified in pairs as indicated. It should now be clear how to prove by induction that the connected sum of n tori is homeomorphic to the quotient space of a $4n$ -gon whose edges are to be identified in pairs according to a scheme, the precise description of which is left to the reader.

Next, we must consider the analogous procedure for the connected sum of projective planes. We have considered the projective plane as the quotient space of a circular disc; diametrically opposite points on the boundary are to be identified. By choosing a pair of diametrically opposite points on the

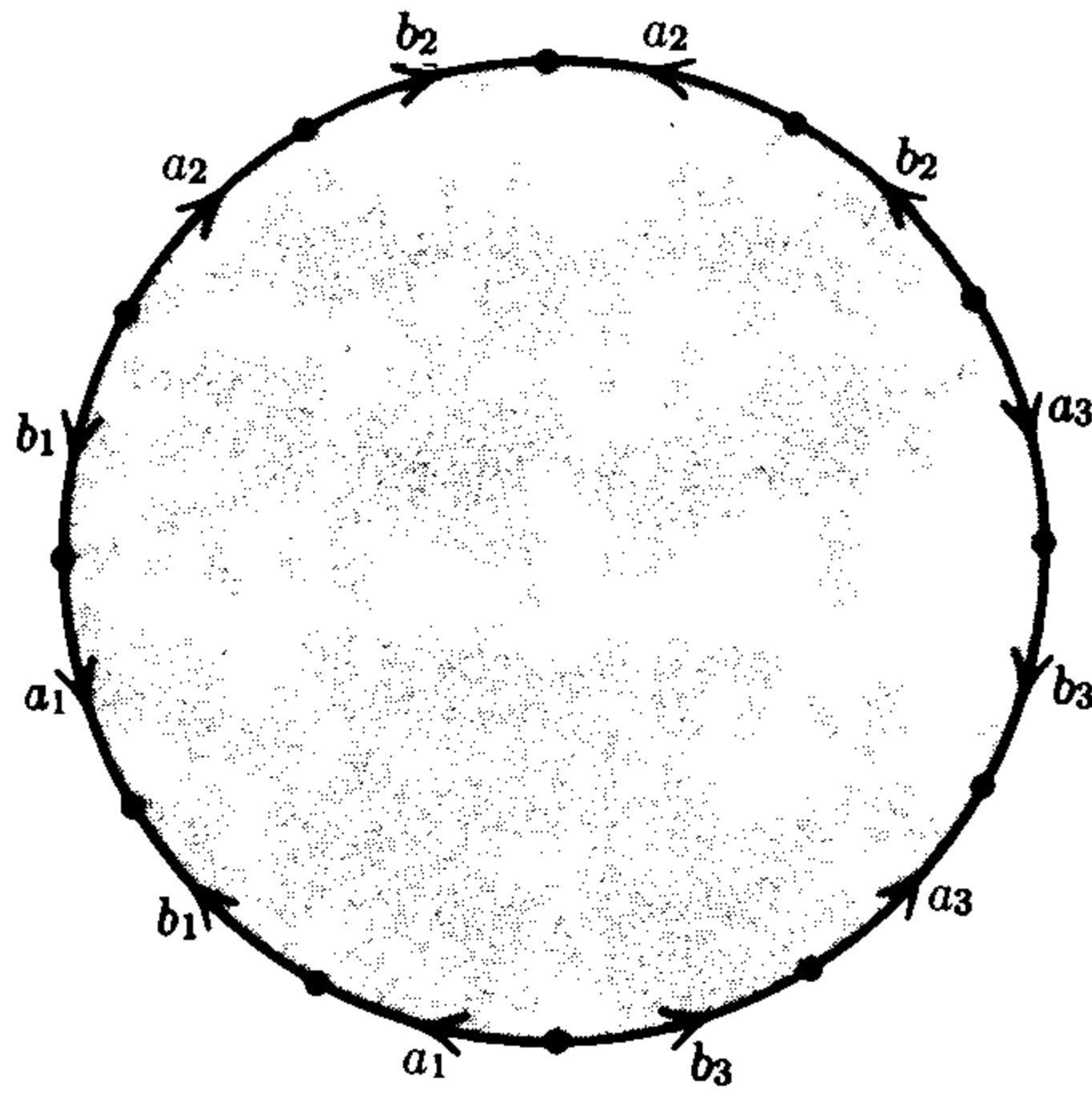

FIGURE 1.7. The connected sum of three tori is obtained by identifying the edges of a 12-gon in pairs as shown.

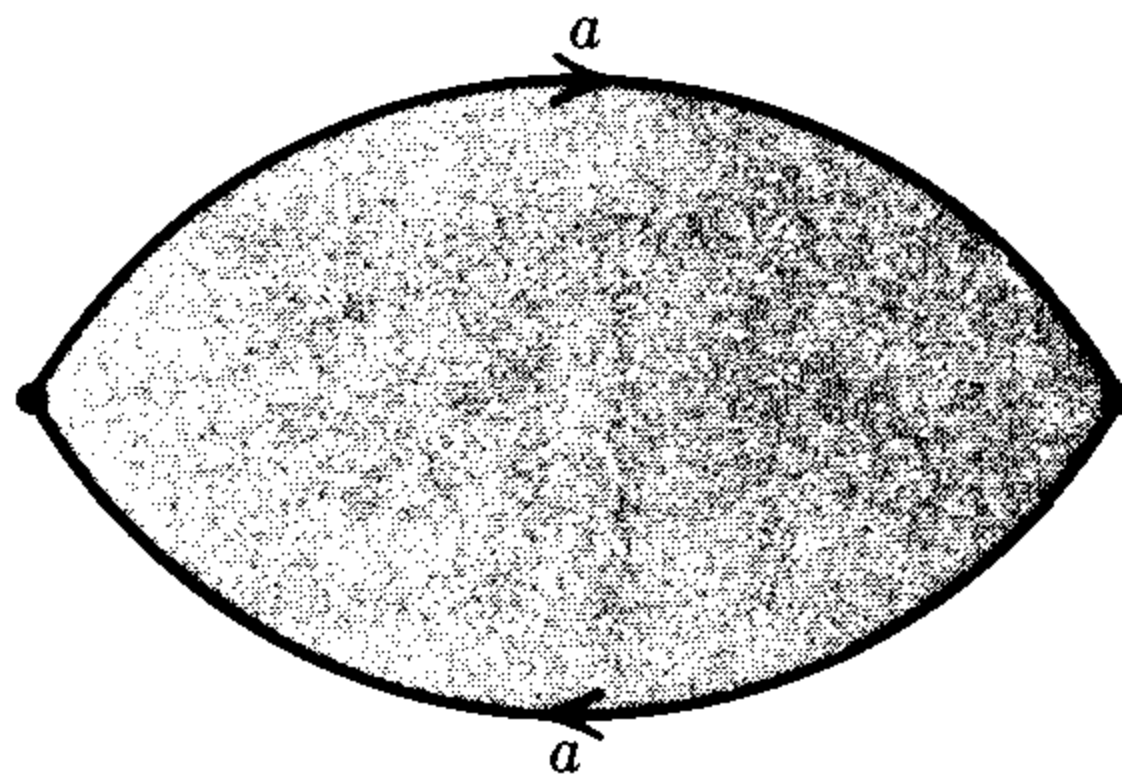

FIGURE 1.8. The projective plane is obtained by identifying opposite edges of a 2-gon.

boundary as vertices, the circumference of the disc is divided into two segments. Thus, we can regard the projective plane as obtained from a 2-gon by identification of the two edges; see Figure 1.8.

Figure 1.9 shows how to obtain a representation of the connected sum of two projective planes as a square with the edges identified in pairs. The method is basically the same as that used to obtain a representation of the connected sum of two tori as a quotient space of an octagon (Figure 1.6). By repeating this process, we see that the connected sum of three projective planes is the quotient space of a hexagon with the sides identified in pairs as indicated in Figure 1.10. By a rather obvious induction, we can prove that, for any positive integer n , the connected sum of n projective planes is the quotient space of a $2n$ -gon with the sides identified in pairs according to a certain scheme. Note that all the vertices of this polygon are identified to one point.

It remains to represent the sphere as the quotient space of a polygon with the sides identified in pairs. We can do this as shown in Figure 1.11. We can think of a sphere with a zipper on it, like a purse; when the zipper is opened, the purse can be flattened out.

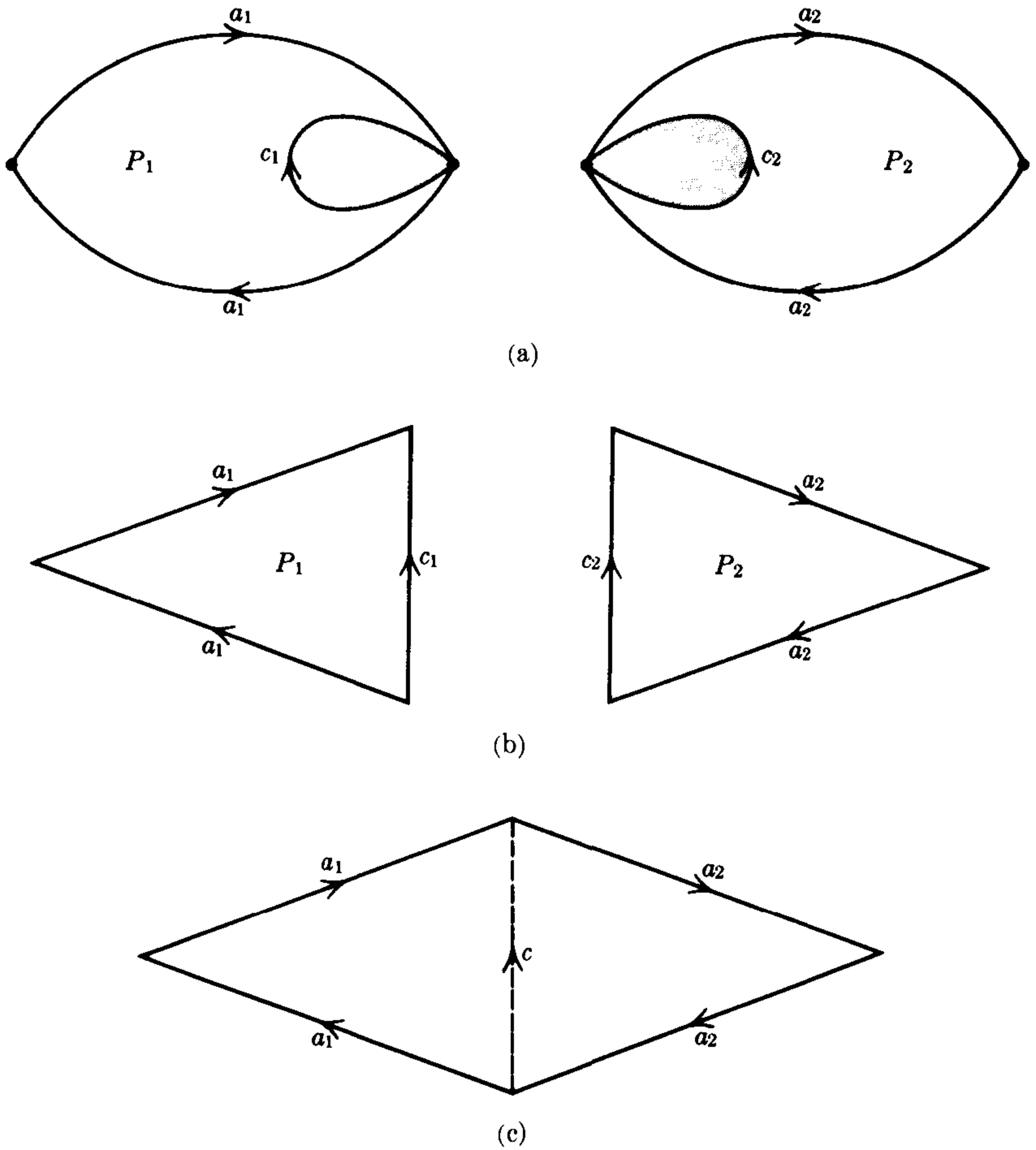

FIGURE 1.9. (a) Two disjoint projective planes, P_1 and P_2 . (b) Disjoint projective planes with holes cut out. (c) After gluing together.

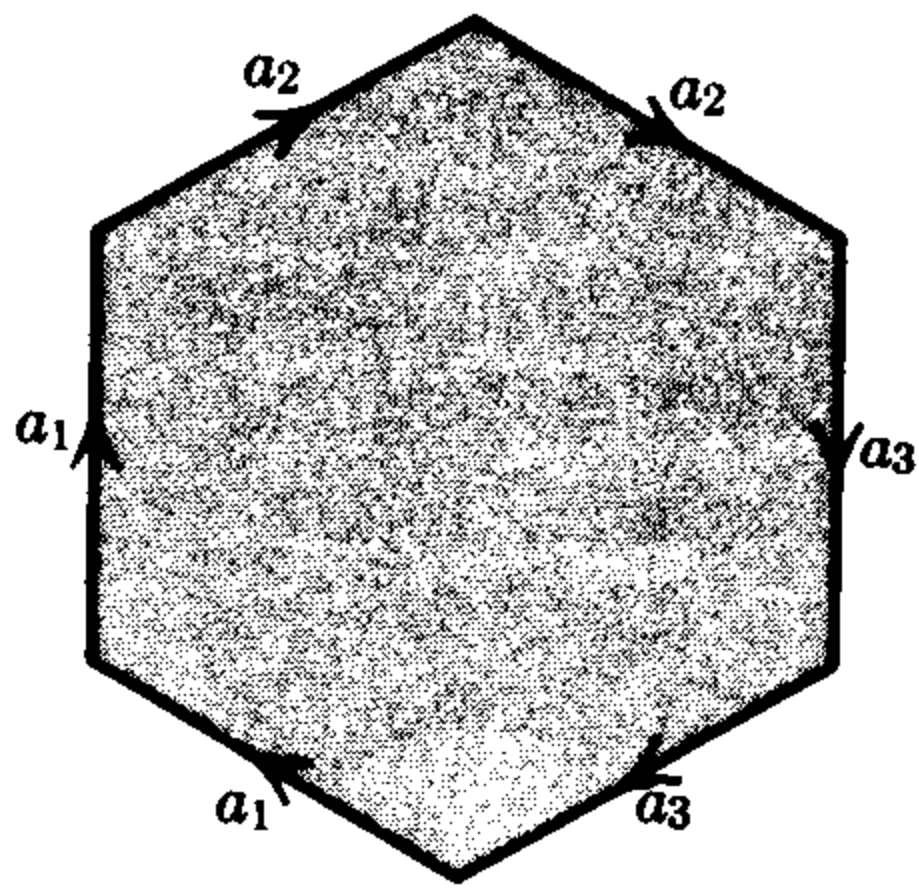

FIGURE 1.10. Construction of the connected sum of three projective planes by identifying the sides of a hexagon in pairs.

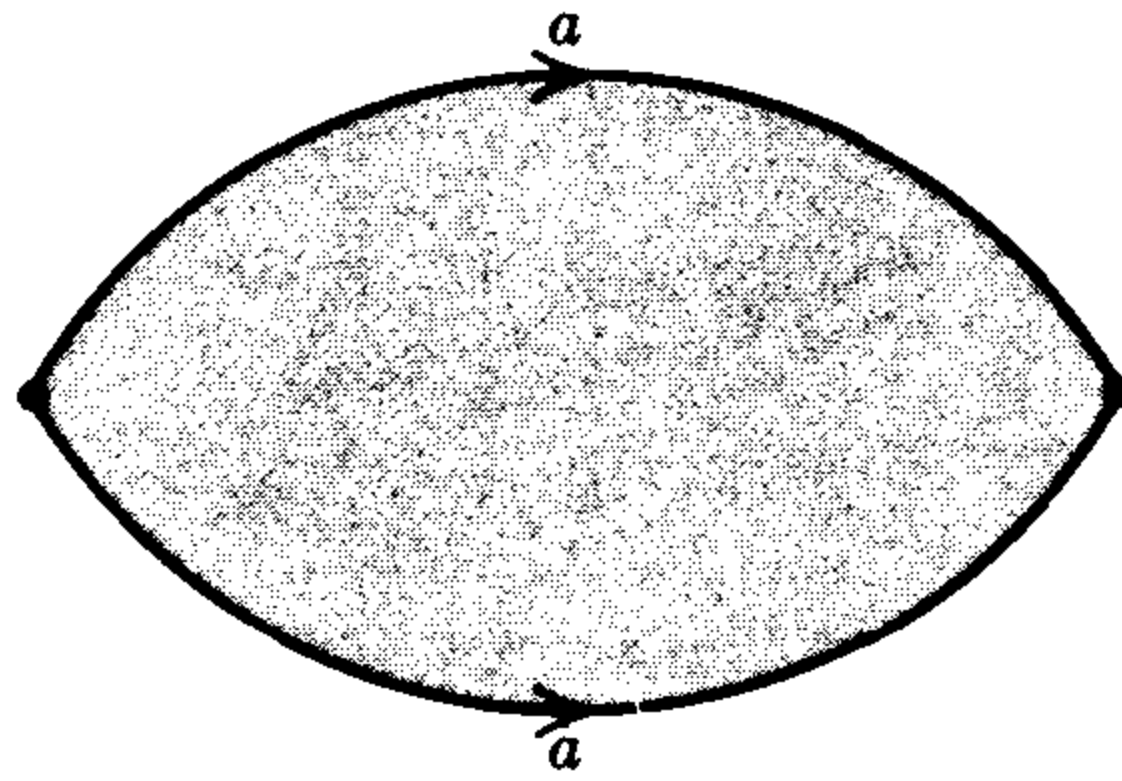

FIGURE 1.11. The sphere is a quotient space of a 2-gon with edges identified as shown.

Thus, we have shown how each of the compact surfaces mentioned in Theorem 5.1 can be considered as the quotient space of a polygon with the edges identified in pairs. We now introduce a rather obvious and convenient method of indicating precisely which paired edges are to be identified in such a polygon. Consider the diagram which indicates how the edges are identified; starting at a definite vertex, proceed around the boundary of the polygon, recording the letters assigned to the different sides in succession. If the arrow on a side points in the *same* direction that we are going around the boundary, then we write the letter for that side with no exponent (or the exponent $+1$). On the other hand, if the arrow points in the *opposite* direction, then we write the letter for that side with the exponent -1 . For example, in Figures 1.7 and 1.10 the identifications are precisely indicated by the symbols

$$a_1 b_1 a_1^{-1} b_1^{-1} a_2 b_2 a_2^{-1} b_2^{-1} a_3 b_3 a_3^{-1} b_3^{-1} \quad \text{and} \quad a_1 a_1 a_2 a_2 a_3 a_3.$$

In each case we started at the bottom vertex of the diagram and read clockwise around the boundary. It is clear that such a symbol unambiguously describes the identifications; on the other hand, in writing the symbol corresponding to a given diagram, we can start at any vertex, and proceed either clockwise or counterclockwise around the boundary.

We summarize our results by writing the symbols corresponding to each of the surfaces mentioned in Theorem 5.1.

- (a) The sphere: aa^{-1} .
 (b) The connected sum of n tori:

$$a_1 b_1 a_1^{-1} b_1^{-1} a_2 b_2 a_2^{-1} b_2^{-1} \dots a_n b_n a_n^{-1} b_n^{-1}.$$

- (c) The connected sum of n projective planes:

$$a_1 a_1 a_2 a_2 \dots a_n a_n.$$

EXERCISES

- 5.1. Let P be a polygon with an even number of sides. Suppose that the sides are identified in pairs in accordance with any symbol whatsoever. Prove that the quotient space is a compact surface.

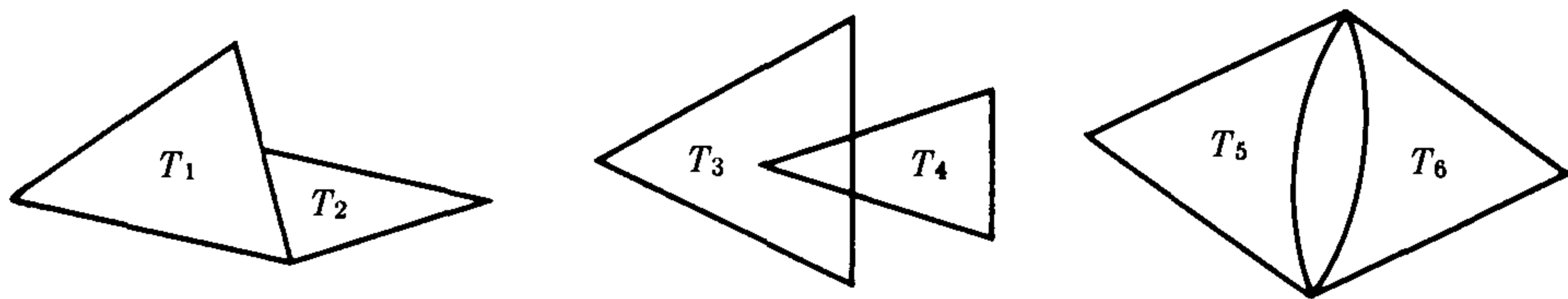

FIGURE 1.12. Some types of intersection forbidden in a triangulation.

§6. Triangulations of Compact Surfaces

To prove Theorem 5.1, we must assume that the given surface is triangulated, i.e., divided up into triangles which fit together nicely. We can easily visualize the surface of the earth divided into triangular regions, and such a subdivision is very useful in the study of compact surfaces in general.

Definition. A *triangulation* of a compact surface S consists of a finite family of closed subsets $\{T_1, T_2, \dots, T_n\}$ that cover S , and a family of homeomorphisms $\varphi_i: T'_i \rightarrow T_i$, $i = 1, \dots, n$, where each T'_i is a triangle in the plane \mathbf{R}^2 (i.e., a compact subset of \mathbf{R}^2 bounded by three distinct straight lines). The subsets T_i are called “triangles.” The subsets of T_i that are the images of the vertices and edges of the triangle T'_i under φ_i are also called “vertices” and “edges,” respectively. Finally, it is required that any two distinct triangles, T_i and T_j , either be disjoint, have a single vertex in common, or have one entire edge in common.

Perhaps the conditions in the definition are clarified by Figure 1.12, which shows three *unallowable* types of intersection of triangles.

Given any compact surface S , it seems plausible that there should exist a triangulation of S . A rigorous proof of this fact (first given by T. Radó in 1925) requires the use of a strong form of the Jordan curve theorem. Although it is not difficult, the proof is tedious, and we will not repeat it here.

We can regard a triangulated surface as having been constructed by gluing together the various triangles in a certain way, much as we put together a jigsaw puzzle or build a wall of bricks. Because two different triangles cannot have the same vertices we can specify completely a triangulation of a surface by numbering the vertices, and then listing which triples of vertices are vertices of a triangle. Such a list of triangles completely determines the surface together with the given triangulation up to homeomorphism.

Examples

6.1. The surface of an ordinary tetrahedron in Euclidean 3-space is homeomorphic to the sphere S^2 ; moreover, the four triangles satisfy all the conditions for a triangulation of S^2 . In this case there are four vertices, and every triple

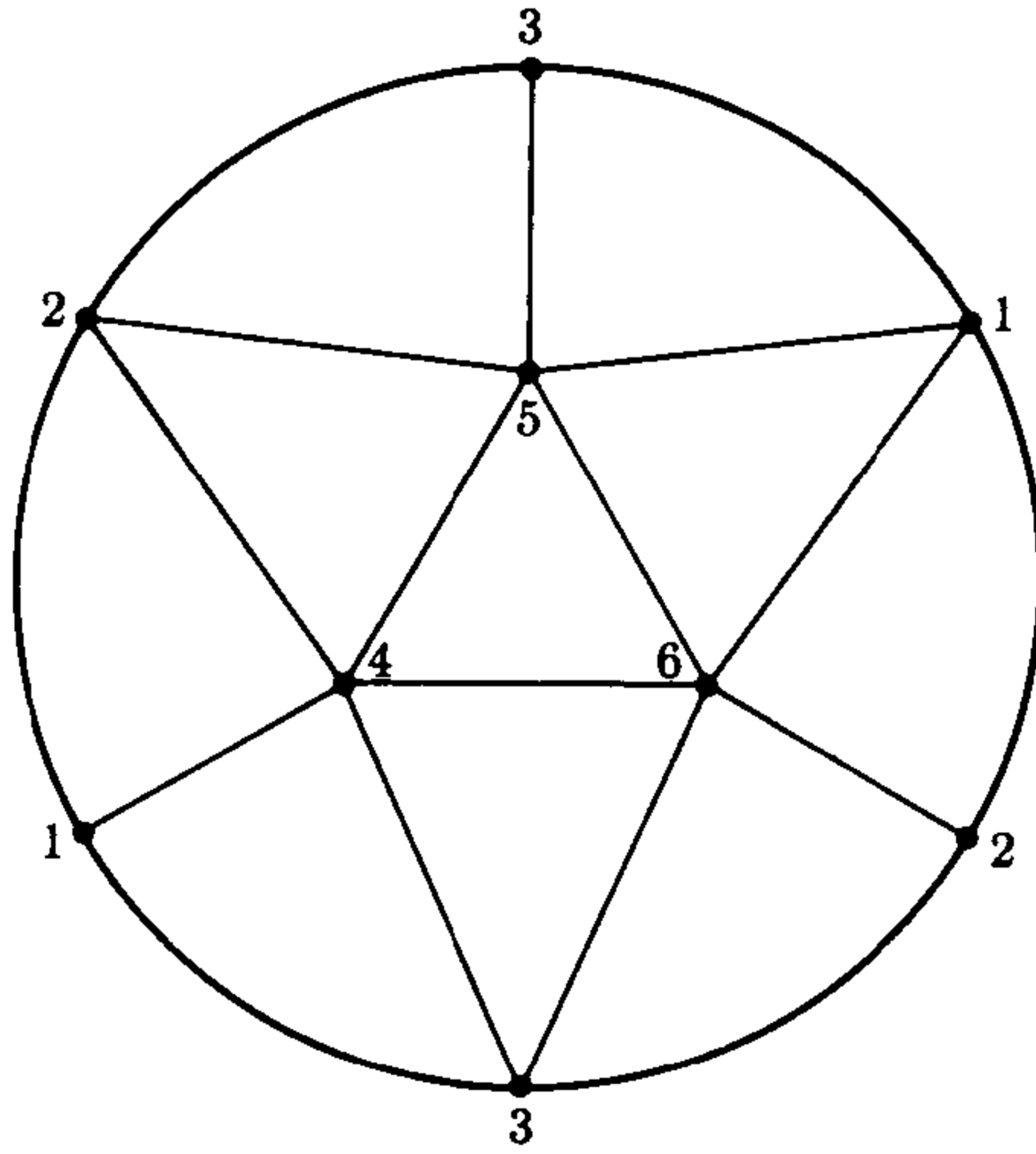

FIGURE 1.13. A triangulation of the projective plane.

of vertices is the set of vertices of a triangle. No other triangulation of any surface can have this property.

6.2. In Figure 1.13 we show a triangulation of the projective plane, considered as the space obtained by identifying diametrically opposite points on the boundary of a disc. The vertices are numbered from 1 to 6, and there are the following 10 triangles:

- | | |
|-----|-----|
| 124 | 245 |
| 235 | 135 |
| 156 | 126 |
| 236 | 346 |
| 134 | 456 |

6.3. In Figure 1.14 we show a triangulation of a torus, regarded as a square with the opposite sides identified. There are 9 vertices, and the following 18 triangles:

- | | | |
|-----|-----|-----|
| 124 | 245 | 235 |
| 356 | 361 | 146 |
| 457 | 578 | 658 |
| 689 | 649 | 479 |
| 187 | 128 | 289 |
| 239 | 379 | 137 |

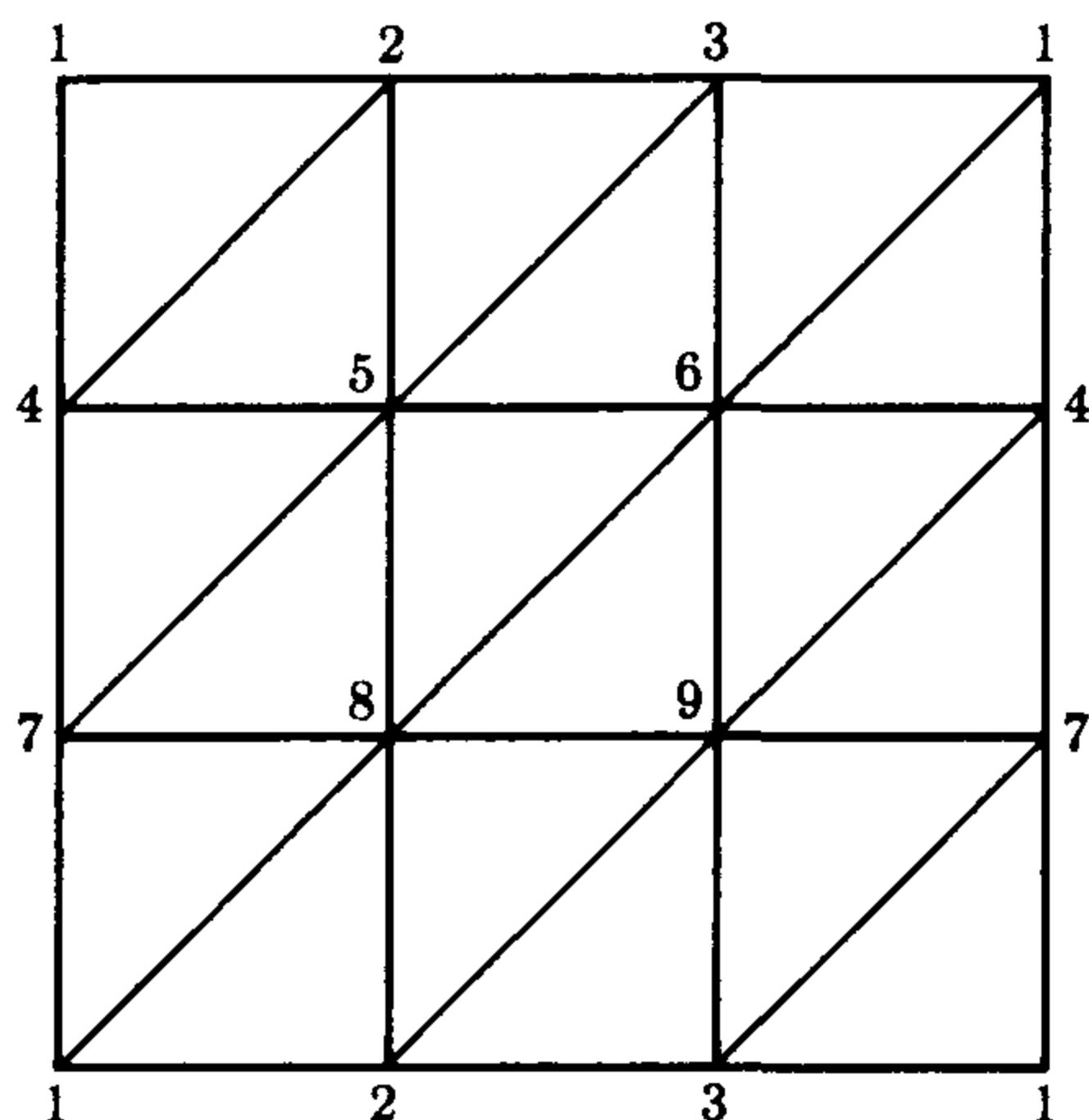

FIGURE 1.14. A triangulation of a torus.

We conclude our discussion of triangulations by noting that any triangulation of a compact surface satisfies the following two conditions:

- (1) Each edge is an edge of exactly two triangles.
- (2) Let v be a vertex of a triangulation. Then we may arrange the set of all triangles with v as a vertex in cyclic order, $T_0, T_1, T_2, \dots, T_{n-1}, T_n = T_0$, such that T_i and T_{i+1} have an edge in common for $0 \leq i \leq n-1$.

The truth of (1) follows from the fact that each point on the edge in question must have an open neighborhood homeomorphic to the open disc U^2 . If an edge were an edge of only one triangle or more than two triangles, this would not be possible. The rigorous proof of this last assertion can be given by using the concept of "The local homology groups at a point." We will take up this concept in Chapter VIII.

Condition (2) can be demonstrated as follows. The fact that the set of all the triangles with v as a vertex can be divided into several disjoint subsets, such that the triangles in each subset can be arranged in cyclic order as described, is an easy consequence of condition (1). However, if there were more than one such subset, then the requirement that v have a neighborhood homeomorphic to U^2 would be violated. This statement can also be proved by using local homology groups at a point.

§7. Proof of Theorem 5.1

Let S be a compact surface. We shall demonstrate Theorem 5.1 by proving that S is homeomorphic to a polygon with the edges identified in pairs as indicated by one of the symbols listed at the end of §5.

First step. From the discussion in the preceding section, we may assume that S is triangulated. Denote the number of triangles by n . We assert that we can number the triangles T_1, T_2, \dots, T_n , so that the triangle T_i has an edge e_i in common with at least one of the triangles T_1, \dots, T_{i-1} , $2 \leq i \leq n$. To prove this assertion, label any of the triangles T_1 ; for T_2 choose any triangle that has an edge in common with T_1 , for T_3 choose any triangle that has an edge in common with T_1 or T_2 , etc. If at any stage we could not continue this process, then we would have two sets of triangles $\{T_1, \dots, T_k\}$, and $\{T_{k+1}, \dots, T_n\}$ such that no triangle in the first set would have an edge or vertex in common with any triangle of the second set. But this would give a partition of S into two disjoint nonempty closed sets, contrary to the assumption that S was connected.

We now use this ordering of the triangles, T_1, T_2, \dots, T_n , together with the choice of edges e_2, e_3, \dots, e_n , to construct a “model” of the surface S in the Euclidean plane; this model will be a polygon whose sides are to be identified in pairs. Recall that for each triangle T_i there exists an ordinary Euclidean triangle T'_i in \mathbf{R}^2 and a homeomorphism φ_i of T'_i onto T_i . We can assume that the triangles T'_1, T'_2, \dots, T'_n are pairwise disjoint; if they are not, we can translate some of them to various other parts of the plane \mathbf{R}^2 . Let

$$T' = \bigcup_{i=1}^n T'_i;$$

then T' is a compact subset of \mathbf{R}^2 . Define a map $\varphi : T' \rightarrow S$ by $\varphi|_{T'_i} = \varphi_i$; the map φ is obviously continuous and onto. Because T' is compact and S is a Hausdorff space, φ is a closed map, and hence S has the quotient topology determined by φ . This is a rigorous mathematical statement of our intuitive idea that S is obtained by gluing the triangles T_1, T_2, \dots together along the appropriate edges.

The polygon we desire will be constructed as a quotient space of T' . Consider any of the edges e_i , $2 \leq i \leq n$. By assumption, e_i is an edge of the triangle T_i and one other triangle T_j , for which $1 \leq j < i$. Therefore, $\varphi^{-1}(e_i)$ consists of an edge of the triangle T'_i and an edge of the triangle T'_j . We identify these two edges of the triangles T'_i and T'_j by identifying points which map onto the same point of e_i (speaking intuitively, we glue together the triangles T'_i and T'_j). We make these identifications for each of the edges e_2, e_3, \dots, e_n . Let D denote the resulting quotient space of T' . It is clear that the map $\varphi : T' \rightarrow S$ induces a map ψ of D onto S , and that S has the quotient topology induced by ψ (because D is compact and S is Hausdorff, ψ is a closed map).

We now assert that topologically D is a closed disc. The proof depends on two facts:

- (a) Let E_1 and E_2 be disjoint spaces, which topologically are closed discs (i.e., they are homeomorphic to E^2). Let A_1 and A_2 be subsets of the boundary of E_1 and E_2 , respectively, which are homeomorphic to the closed interval $[0, 1]$, and let $h : A_1 \rightarrow A_2$ be a definite homeomorphism. Form a quotient space of $E_1 \cup E_2$ by identifying points that correspond under h . Then,

topologically, the quotient space is also a closed disc. The reader may either take this very plausible fact for granted, or construct a proof using the type of argument given in II.8. Intuitively, it means that if we glue two discs together along a common segment of their boundaries, the result is again a disc.

- (b) In forming the quotient space D of T' , we may either make all the identifications at once, or make the identifications corresponding to e_2 , then those corresponding to e_3 , etc., in succession. This is a consequence of standard theorems about quotient spaces.

We now use these facts to prove that D is a disc as follows. T'_1 and T'_2 are topologically equivalent to discs. Therefore, the quotient space of $T'_1 \cup T'_2$ obtained by identifying points of $\varphi^{-1}(e_2)$ is again a disc by (a). Form a quotient space of this disc and T'_3 by making the identifications corresponding to the edge e_3 , etc.

It is clear that S is obtained from D by identifying certain paired edges on the boundary of D .

Examples

7.1. Figure 1.15 shows an easily visualized example. The surface of a cube has been triangulated by dividing each face by a diagonal into two triangles. The resulting disc D might look like the diagram, depending, of course, on how the triangles were enumerated, and how the edges e_2, \dots, e_{12} were chosen. The edges to D that are to be identified are labeled in the usual way. At this stage, we can forget about the edges e_2, e_3, \dots, e_{12} . Thus, instead of the polygon in Figure 1.15, we could work equally well with the one in Figure 1.16.

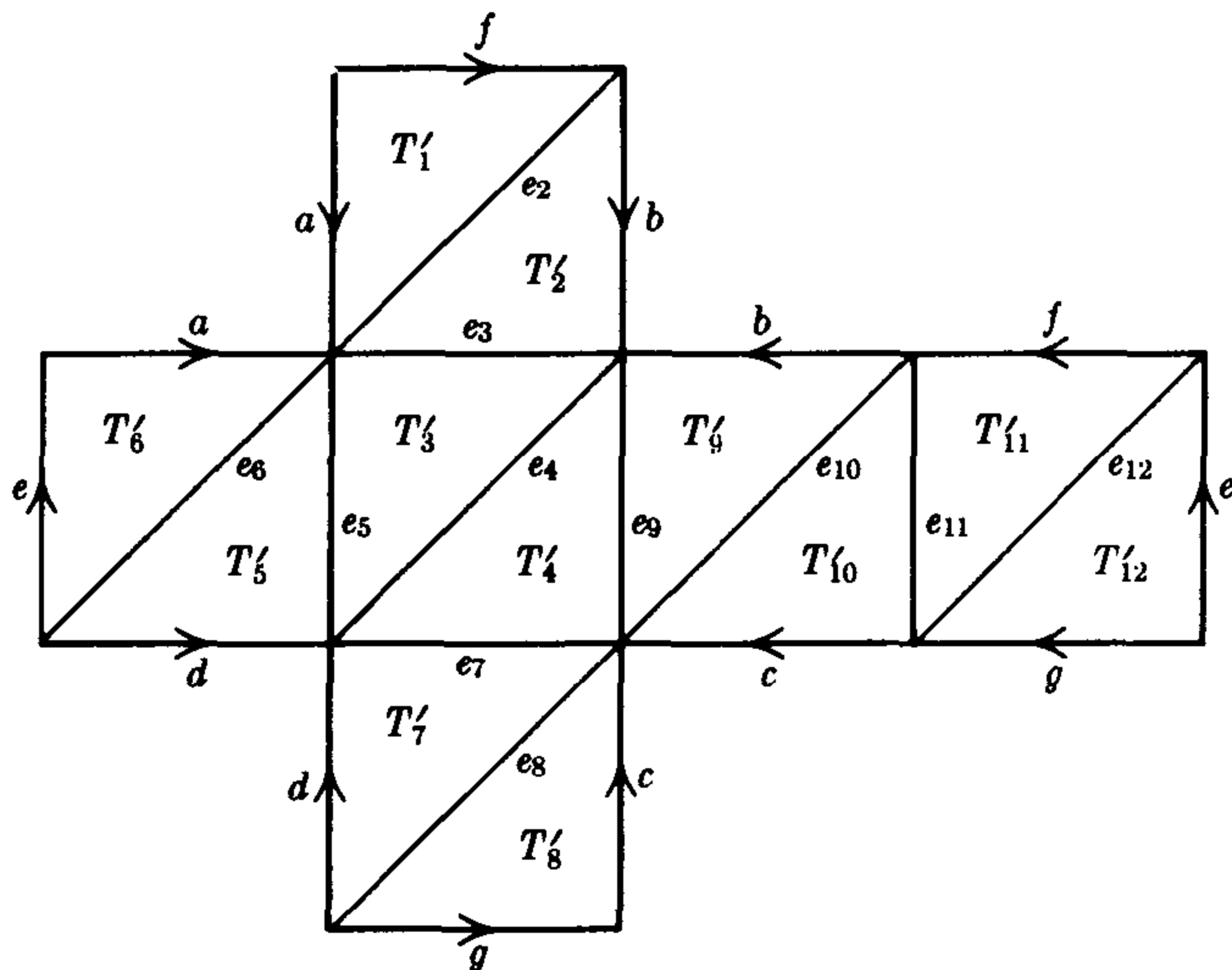

FIGURE 1.15. Example illustrating the first step of the proof of Theorem 5.1.

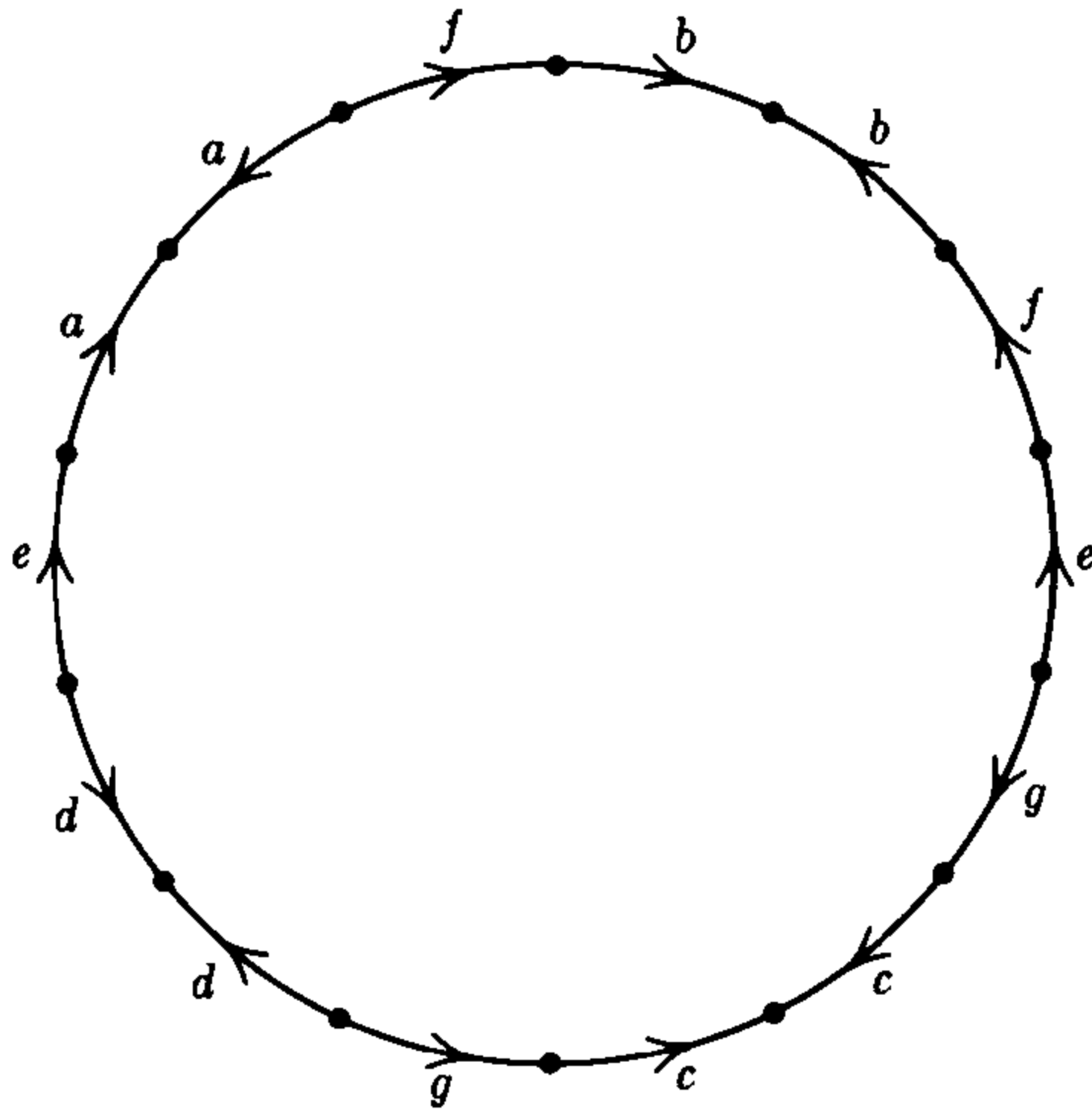

FIGURE 1.16. Simplified version of polygon shown in Figure 1.15.

EXERCISES

Carry out the above process for each of the surfaces whose triangulations are given below. (NOTE: these examples will be used later.)

- | | | | | | | |
|------|-----|-----|-----|-----|-----|-----|
| 7.1. | 124 | 236 | 134 | 246 | | |
| | 367 | 347 | 469 | 459 | | |
| | 698 | 678 | 457 | 259 | | |
| | 289 | 578 | 358 | 125 | | |
| | 238 | 135 | | | | |
| 7.2. | 123 | 234 | 341 | 412 | | |
| 7.3. | 123 | 234 | 345 | 451 | 512 | |
| | 136 | 246 | 356 | 416 | 526 | |
| 7.4. | 124 | 235 | 346 | 457 | 561 | 672 |
| | 713 | 134 | 245 | 356 | 467 | 571 |
| | 126 | 237 | | | | |
| 7.5. | 123 | 256 | 341 | 451 | | |
| | 156 | 268 | 357 | 468 | | |
| | 167 | 275 | 374 | 476 | | |
| | 172 | 283 | 385 | 485 | | |

Second step. Elimination of adjacent edges of the first kind. We have now obtained a polygon D whose edges have to be identified in pairs to obtain the given surface S . These identifications may be indicated by the appropriate symbol; e.g., in Figure 1.16, the identifications are described by

$$aa^{-1}fbb^{-1}f^{-1}e^{-1}gcc^{-1}g^{-1}dd^{-1}e.$$

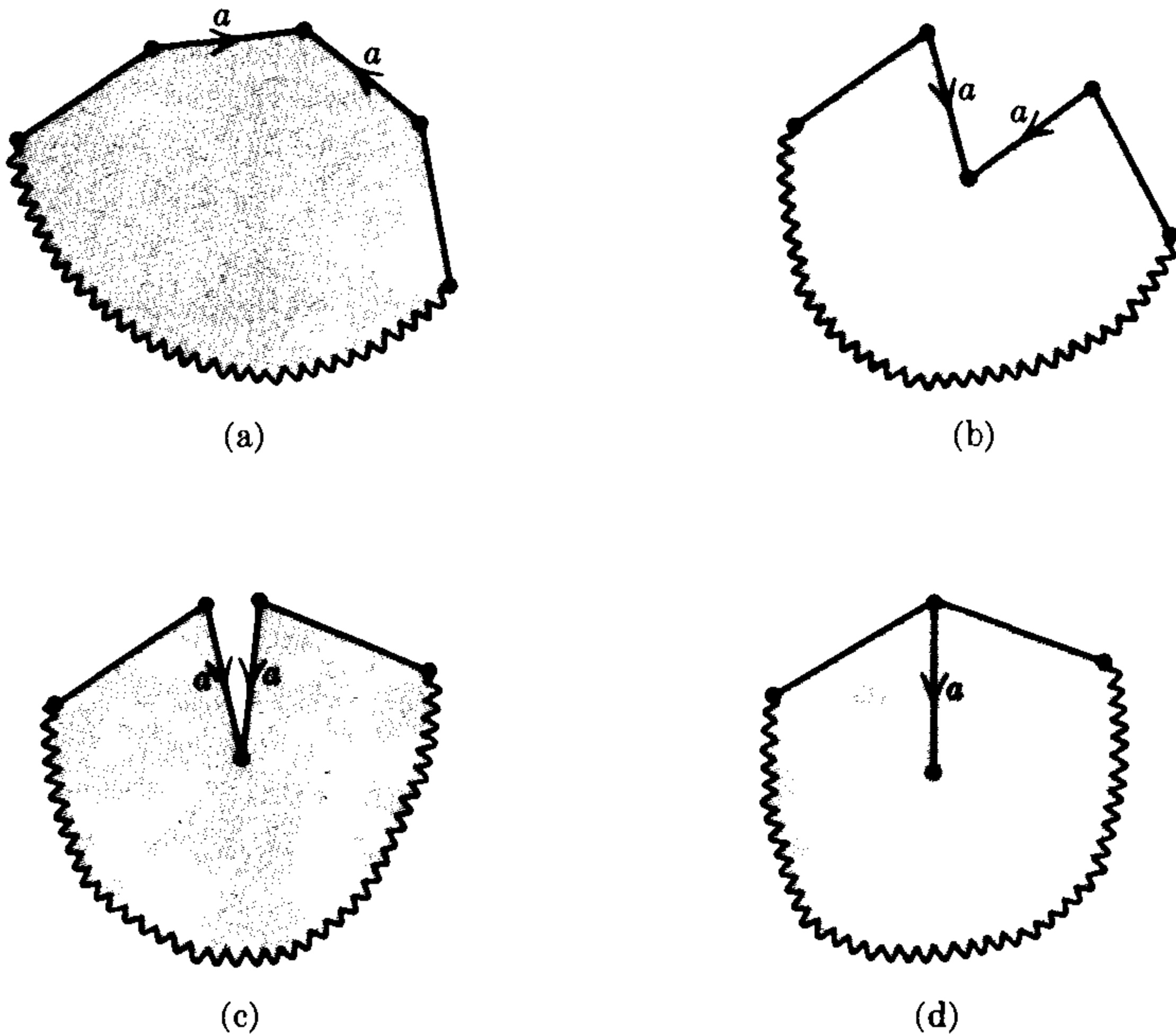

FIGURE 1.17. Elimination of an adjacent pair of edges of the first kind.

If the letter designating a certain pair of edges occurs with *both* exponents, $+1$ and -1 , in the symbol, then we will call that pair of edges a pair of the *first kind*; otherwise, the pair is of the *second kind*. For example, in Figure 1.16, all seven pairs are of the first kind.

We wish to show that an adjacent pair of edges of the first kind can be eliminated, provided there are at least four edges in all. This is easily seen from the sequence of diagrams in Figure 1.17. We can continue this process until all such pairs are eliminated, or until we obtain a polygon with only two sides. In the latter case, this polygon, whose symbol will be aa or aa^{-1} , must be a projective plane or a sphere, and we have completed the proof. Otherwise, we proceed as follows.

Third step. Transformation to a polygon such that all vertices must be identified to a single vertex. Although the edges of our polygon must be identified in pairs, the vertices may be identified in sets of one, two, three, four, Let us call two vertices of the polygon *equivalent* if and only if they are to be identified. For example, the reader can easily verify that in Figure 1.16 there are eight different equivalence classes of vertices. Some equivalence classes contain only one vertex, whereas other classes contain two or three vertices.

Assume we have carried out step two as far as possible. We wish to prove we can transform our polygon into another polygon with all its vertices belonging to one equivalence class.

Suppose there are at least two different equivalence classes of vertices. Then,

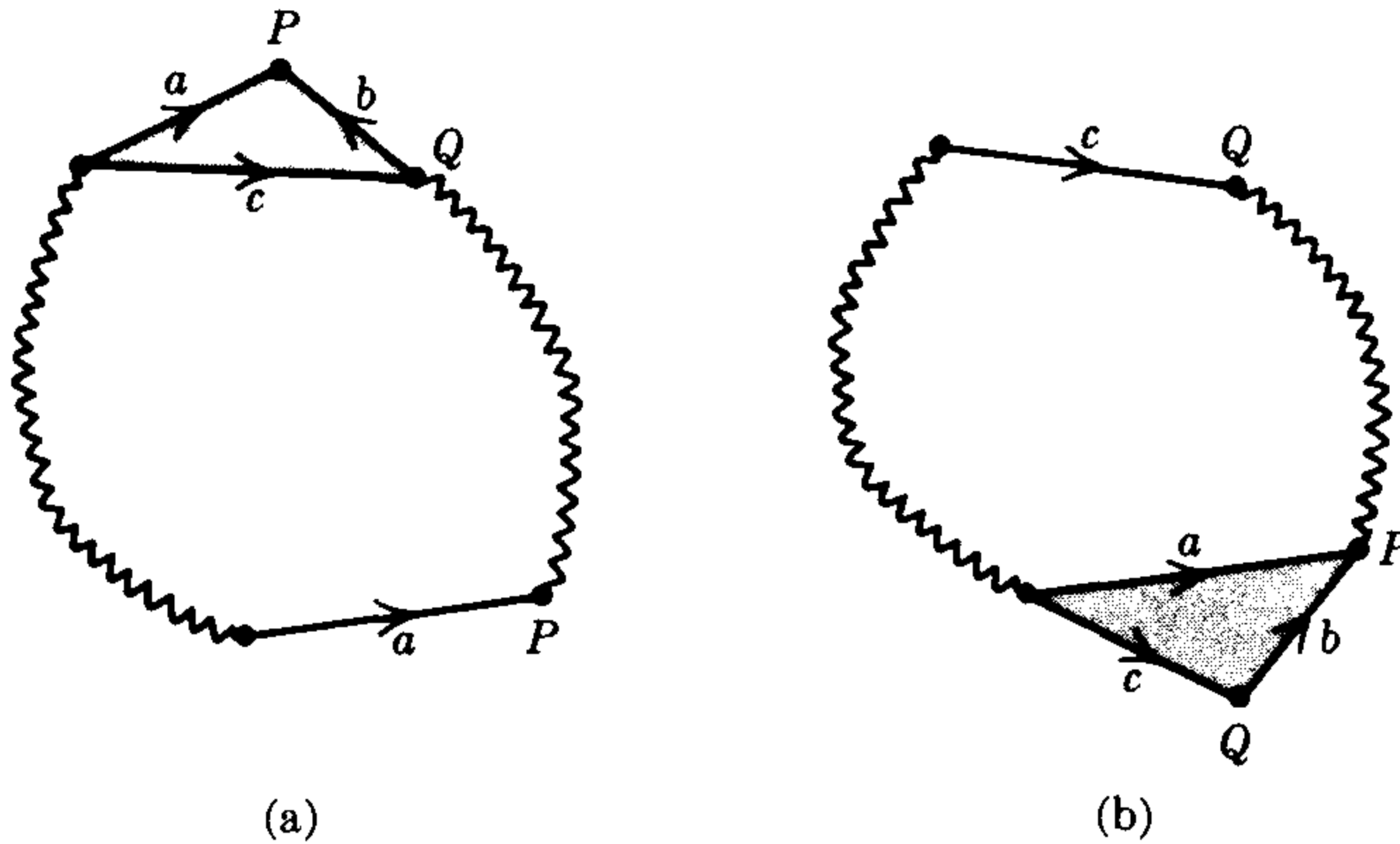

FIGURE 1.18. Third step in the proof of Theorem 5.1.

the polygon must have an adjacent pair of vertices which are nonequivalent. Label these vertices P and Q . Figure 1.18 shows how to proceed. As P and Q are nonequivalent, and we have carried out step two, it follows that sides a and b are *not* to be identified. Make a cut along the line labeled c , from the vertex labeled Q to the other vertex of the edge a (i.e., to the vertex of edge a , which is distinct from P). Then, glue the two edges labeled a together. A new polygon with one less vertex in the equivalence class of P and one more vertex in the equivalence class of Q results. If possible, perform step two again. Then carry out step three to reduce the number of vertices in the equivalence class of P still further, then do step two again. Continue alternately doing step three and step two until the equivalence class of P is eliminated entirely. If more than one equivalence class of vertices remains, we can repeat this procedure to reduce the number by 1. If we continue in this manner, we ultimately obtain a polygon such that all the vertices are to be identified to a single vertex.

Fourth step. How to make any pair of edges of the second kind adjacent. We wish to show that our surface can be transformed so that any pair of edges of the second kind are adjacent to each other. Suppose we have a pair of edges of the second kind which are nonadjacent, as in Figure 1.19(a). Cut along the

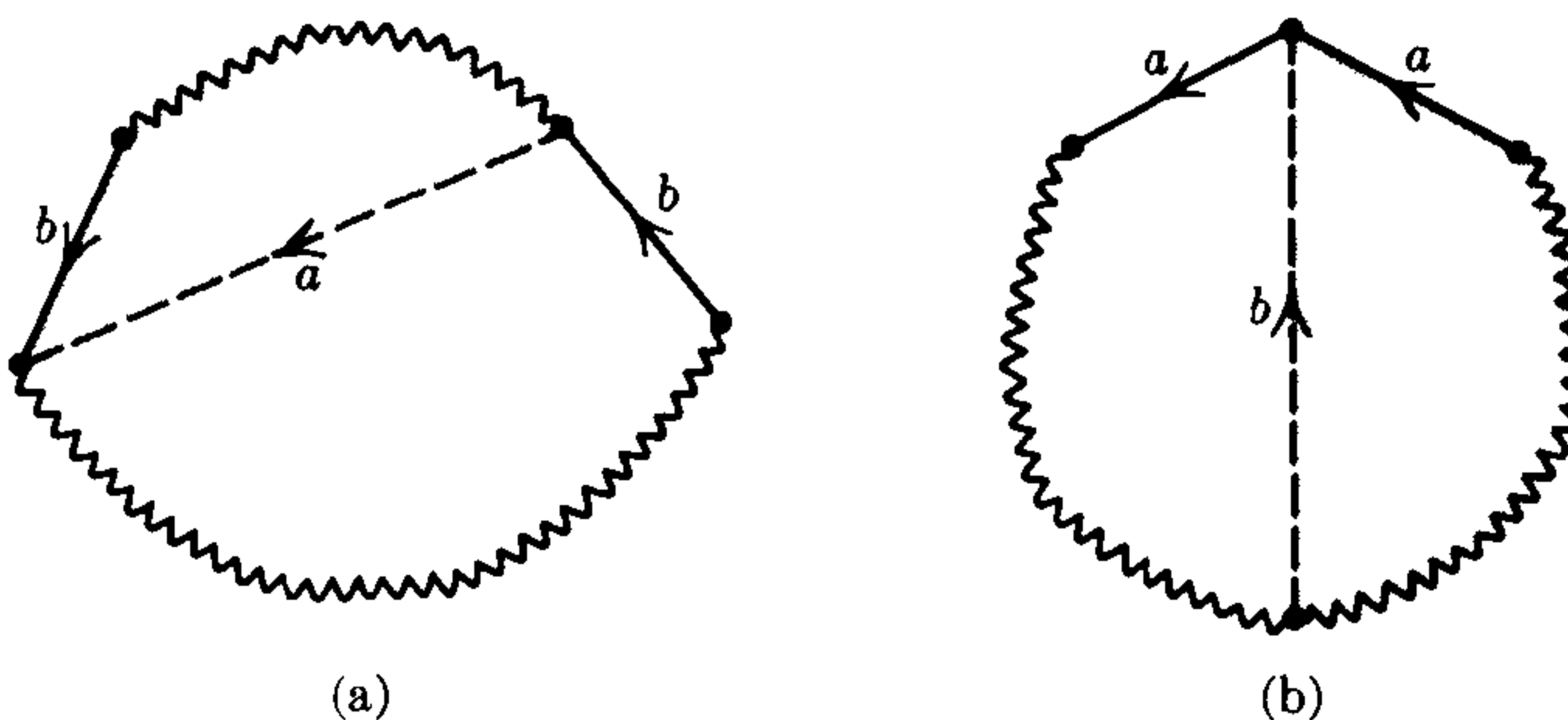

FIGURE 1.19. Fourth step in the proof of Theorem 5.1.

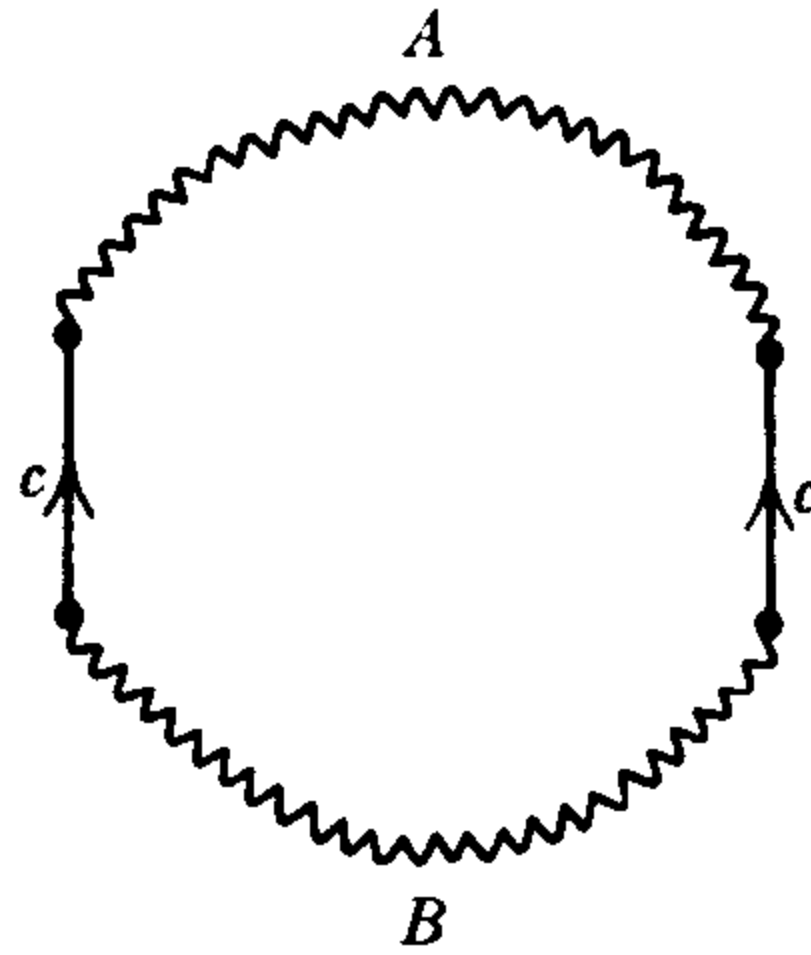

FIGURE 1.20. A pair of edges of the first kind.

dotted line labeled a and paste together along b . As shown in Figure 1.19(b), the two edges are now adjacent.

Continue this process until all pairs of edges of the second kind are adjacent. If there are no pairs of the first kind, we are finished, because the symbol of the polygon must then be of the form $a_1 a_1 a_2 a_2 \dots a_n a_n$, and hence S is the connected sum of n projective planes.

Assume to the contrary that at this stage there is at least one pair of edges of the first kind, each of which is labeled with the letter c . Then we assert that there is at least one other pair of edges of the first kind such that these two pairs separate one another; i.e., edges from the two pairs occur alternately as we proceed around the boundary of the polygon (hence, the symbol must be of the form $c \dots d \dots c^{-1} \dots d^{-1} \dots$, where the dots denote the possible occurrence of other letters).

To prove this assertion, assume that the edges labeled c are not separated by any other pair of the first kind. Then our polygon has the appearance indicated in Figure 1.20. Here A and B each designate a whole sequence of edges. The important point is that any edge in A must be identified with another edge in A , and similarly for B . No edge in A is to be identified with an edge in B . But this contradicts the fact that the initial and final vertices of either edge labeled c are to be identified, in view of step three.

Fifth step. Pairs of the first kind. Suppose, then, that we have two pairs of the first kind which separate each other as described (see Figure 1.21). We shall show that we can transform the polygon so that the four sides in question are consecutive around the perimeter of the polygon.

First, cut along c and paste together along b to obtain Figure 1.21(b). Then, cut along d and paste together along a to obtain Figure 1.21(c), as desired.

Continue this process until all pairs of the first kind are in adjacent groups of four, as $cdc^{-1}d^{-1}$ in Figure 1.21(c). If there are no pairs of the second kind, this leads to the desired result because, in that case, the symbol must be of the form

$$a_1 b_1 a_1^{-1} b_1^{-1} a_2 b_2 a_2^{-1} b_2^{-1} \dots a_n b_n a_n^{-1} b_n^{-1}$$

and the surface is the connected sum of n tori.

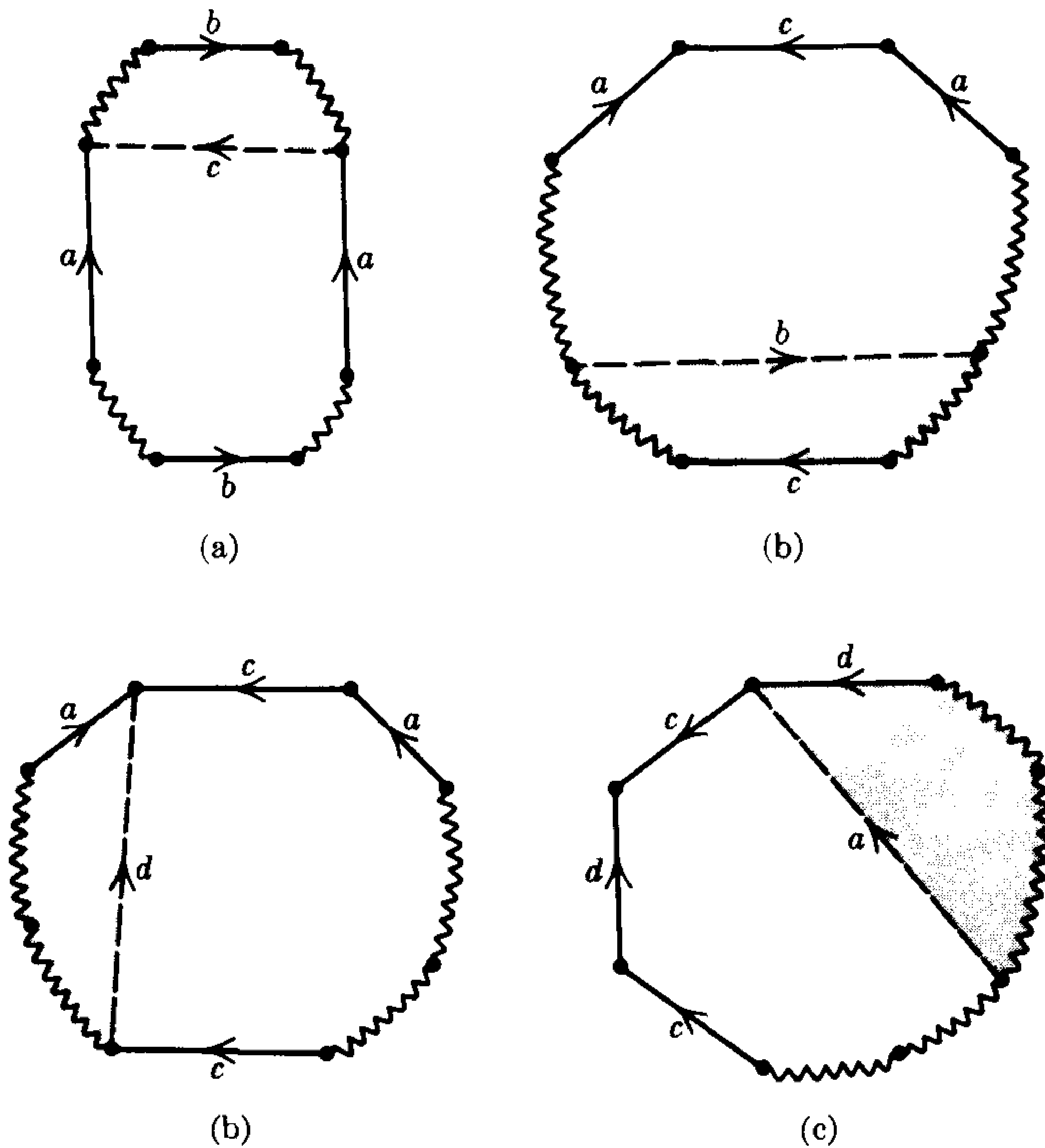

FIGURE 1.21. Fifth step in the proof of Theorem 5.1.

It remains to treat the case in which there are pairs of both the first and second kind at this stage. The key to the situation is the following rather surprising lemma:

Lemma 7.1. *The connected sum of a torus and a projective plane is homeomorphic to the connected sum of three projective planes.*

PROOF. We have remarked that the connected sum of two projective planes is homeomorphic to a Klein bottle (see Example 4.3). Thus, we must prove that the connected sum of a projective plane and a torus is homeomorphic to the connected sum of a projective plane and a Klein bottle. To do this, it will be convenient to give an alternative construction for a connected sum of any surface S with a torus or a Klein bottle. We can represent the torus and Klein bottle as rectangles with opposite sides identified as shown in Figure 1.22. To form the connected sum, we first cut out the disc that is shaded in the diagrams, cut a similar hole in S , and glue the boundary of the hole in the torus or Klein bottle to the boundary of the hole in S . However, instead of gluing on the entire torus or Klein bottle in one step, we may do it in two stages: First, glue on the part of the torus or Klein bottle that is the image of the rectangle

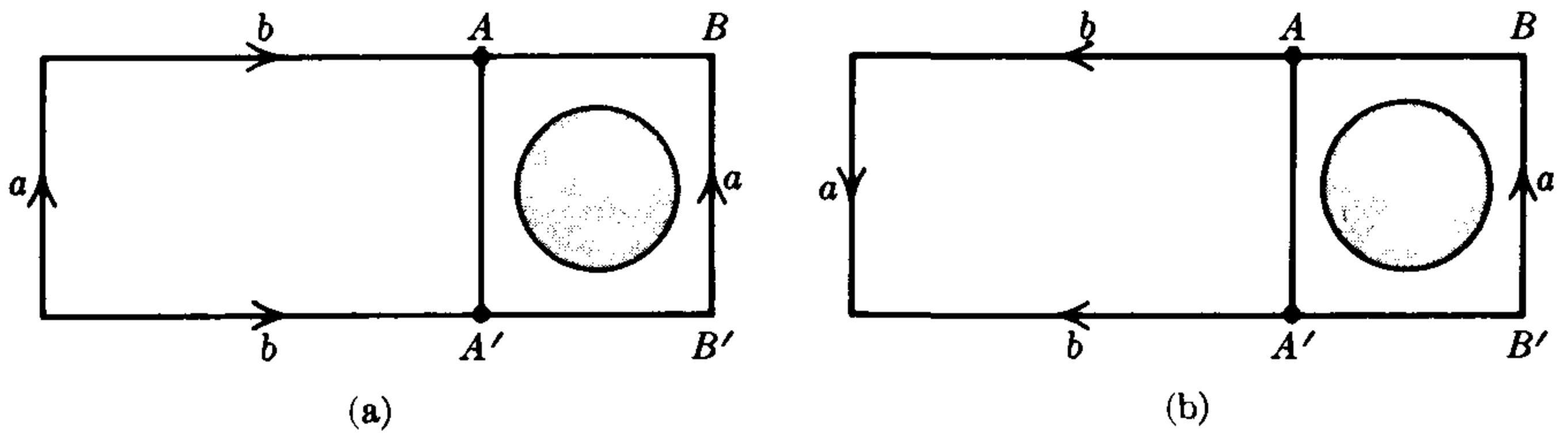

FIGURE 1.22. (a) Torus with hole. (b) Klein bottle with hole.

$ABB'A'$ under the identification, and then glue on the rest of the torus or Klein bottle. In the first stage we form the connected sum of S with an open tube or cylinder. Such an open tube or cylinder is homeomorphic to a sphere with two holes cut in it, and forming the connected sum of S with a sphere does not change anything. Thus, the space resulting from the first stage is homeomorphic to the original surface S with two holes cut in it. In the second stage we then connect the boundaries of these two holes with a tube that is the remainder of the torus or Klein bottle. The difference between the two cases depends on whether we connect the boundaries so they will have the same or opposite orientations. This is illustrated in Figure 1.23, where S is a Möbius strip.

We now assert that the two spaces shown in Figures 1.23(a) and 1.23(b) (i.e., the connected sum of a Möbius strip with a torus and a Klein bottle, respectively) are homeomorphic. To see this, imagine that we cut each of these topological spaces along the lines AB . In each case, the result is the connected sum of a rectangle and a torus, with the two ends of the rectangle to be identified with a twist, as shown in Figure 1.24. Hence, the two spaces are homeomorphic.

As stated previously, we obtain the projective plane by gluing the boundary of a disc to the boundary of a Möbius strip. As the spaces shown in Figure 1.23 are homeomorphic, so are the spaces obtained by gluing a disc on the boundary of each. Thus, the connected sum of a projective plane and a torus is homeomorphic to the connected sum of a projective plane and a Klein bottle, as was to be proved. Q.E.D.

It should be clear that this lemma takes care of the remaining case. Assume that after the fifth step has been completed, the polygon has m pairs ($m > 0$) of the second kind such that the two edges of each pair are adjacent, and n quadruples ($n > 0$) of sides, each quadruple consisting of two pairs of the first kind which separate each other. Then, the surface is the connected sum of m projective planes and n tori, which by the lemma is homeomorphic to the connected sum of $m + 2n$ projective planes. This completes the proof of Theorem 5.1.

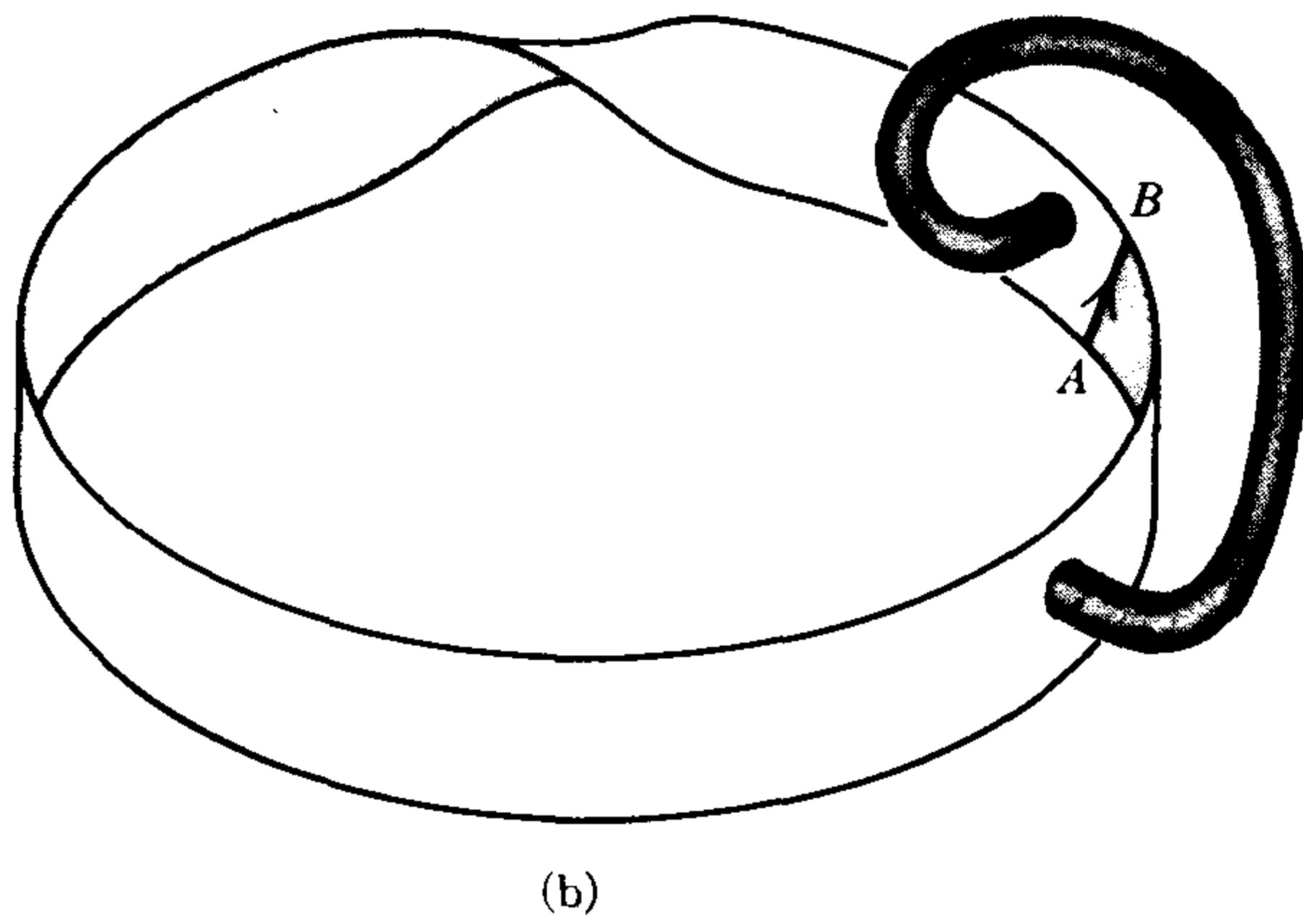
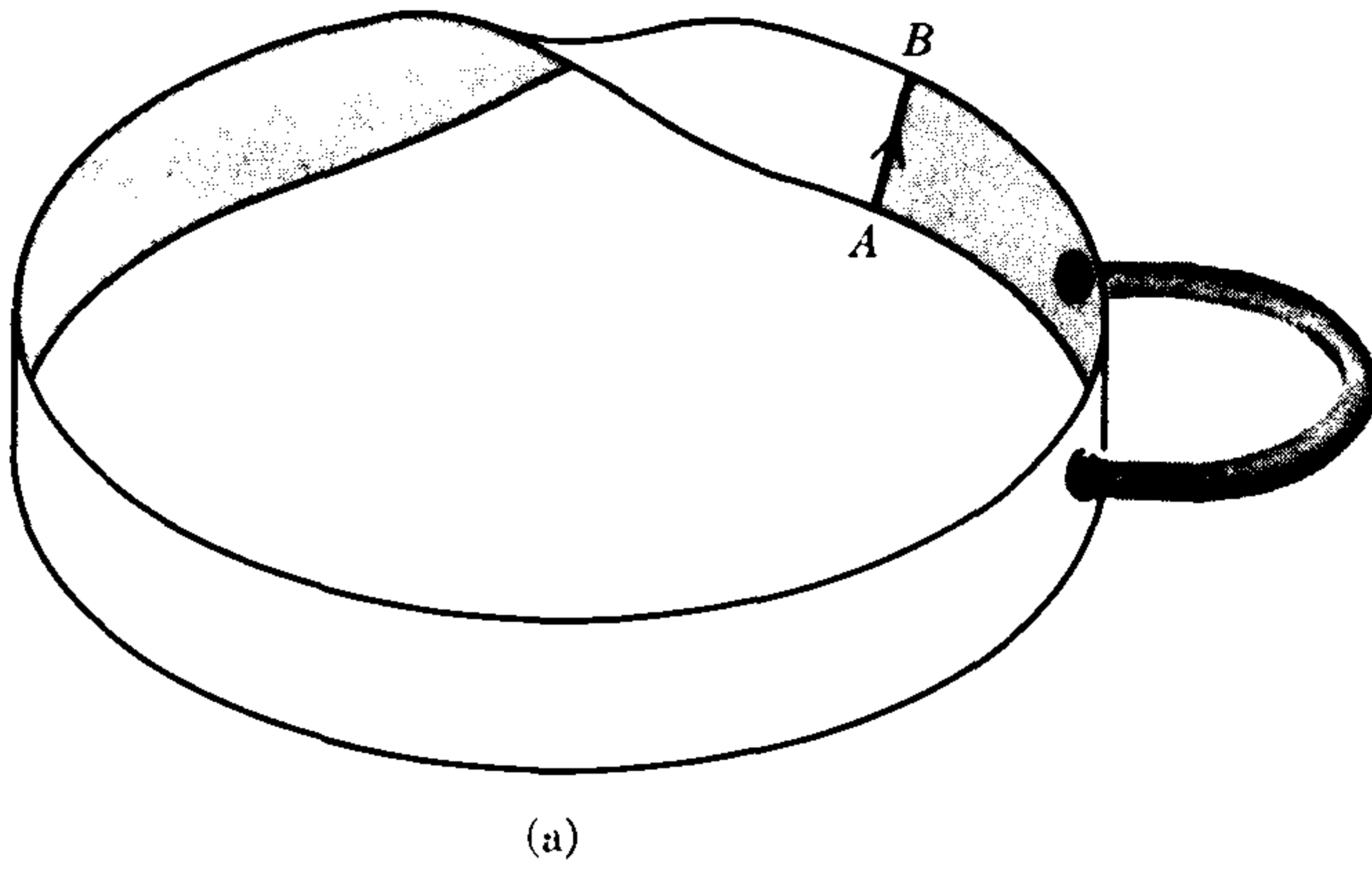

FIGURE 1.23. (a) Connected sum of a Möbius strip and a torus. (b) Connected sum of a Möbius strip and a Klein bottle.

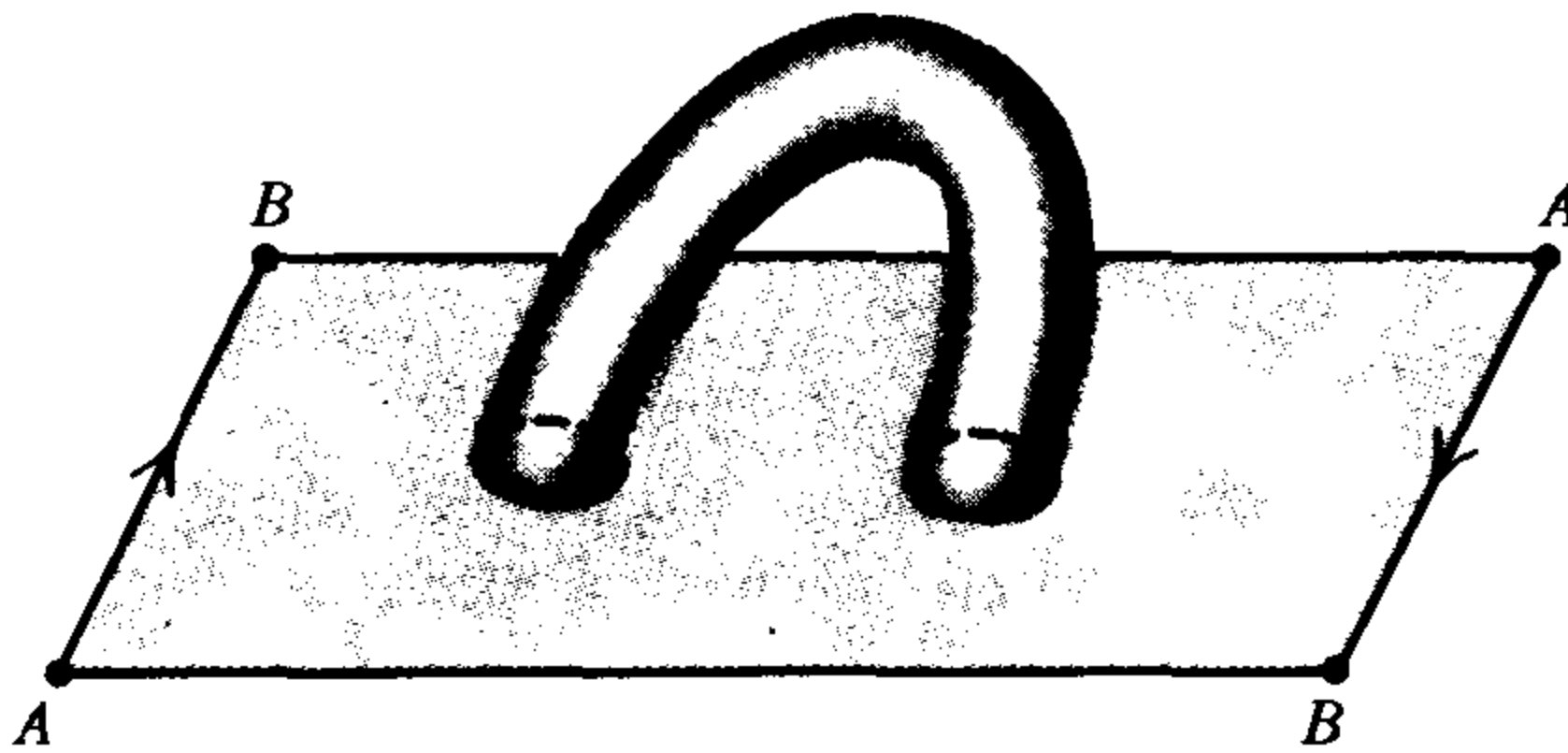

FIGURE 1.24. The result of cutting the spaces shown in Figure 1.23 along the line AB .

EXERCISES

7.6. Carry out each of the above steps for the examples given in Exercises 7.1–7.5.

It is clear that we can also work the process described above backwards; whenever there are three pairs of the second kind, we can replace them by one pair of the second kind and two pairs of the first kind. Alternatively, we can apply Lemma 7.1 to any connected sum of which three or more of the summands are projective planes. The following alternative form of Theorem 5.1, which may be preferable in some cases, results.

Theorem 7.2. *Any compact, orientable surface is homeomorphic to a sphere or a connected sum of tori. Any compact, nonorientable surface is homeomorphic to the connected sum of either a projective plane or Klein bottle and a compact, orientable surface.*

§8. The Euler Characteristic of a Surface

Although we have shown that any compact surface is homeomorphic to a sphere, a sum of tori, or a sum of projective planes, we do not know that all these are topologically different. It is conceivable that there exist positive integers m and n , $m \neq n$, such that the sum of m tori is homeomorphic to the sum of n tori. To show that this cannot happen, we introduce a numerical invariant called the *Euler characteristic*.

First, we define the Euler characteristic of a triangulated surface. Let M be a compact surface with triangulation $\{T_1, \dots, T_n\}$. Let

v = total number of vertices of M ,

e = total number of edges of M ,

t = total number of triangles (in this case, $t = n$).

Then,

$$\chi(M) = v - e + t$$

is called the *Euler characteristic* of M .

Example

8.1. Figure 1.25 suggests uniform methods of triangulating the sphere, torus, and projective plane so that we may make the number of triangles as large as we please. Using such triangulations, the reader should verify that the Euler characteristics of the sphere, torus, and projective plane are 2, 0, and 1, respectively. He should also verify that the Euler characteristics are independent of the number of vertical and horizontal dividing lines in the diagrams

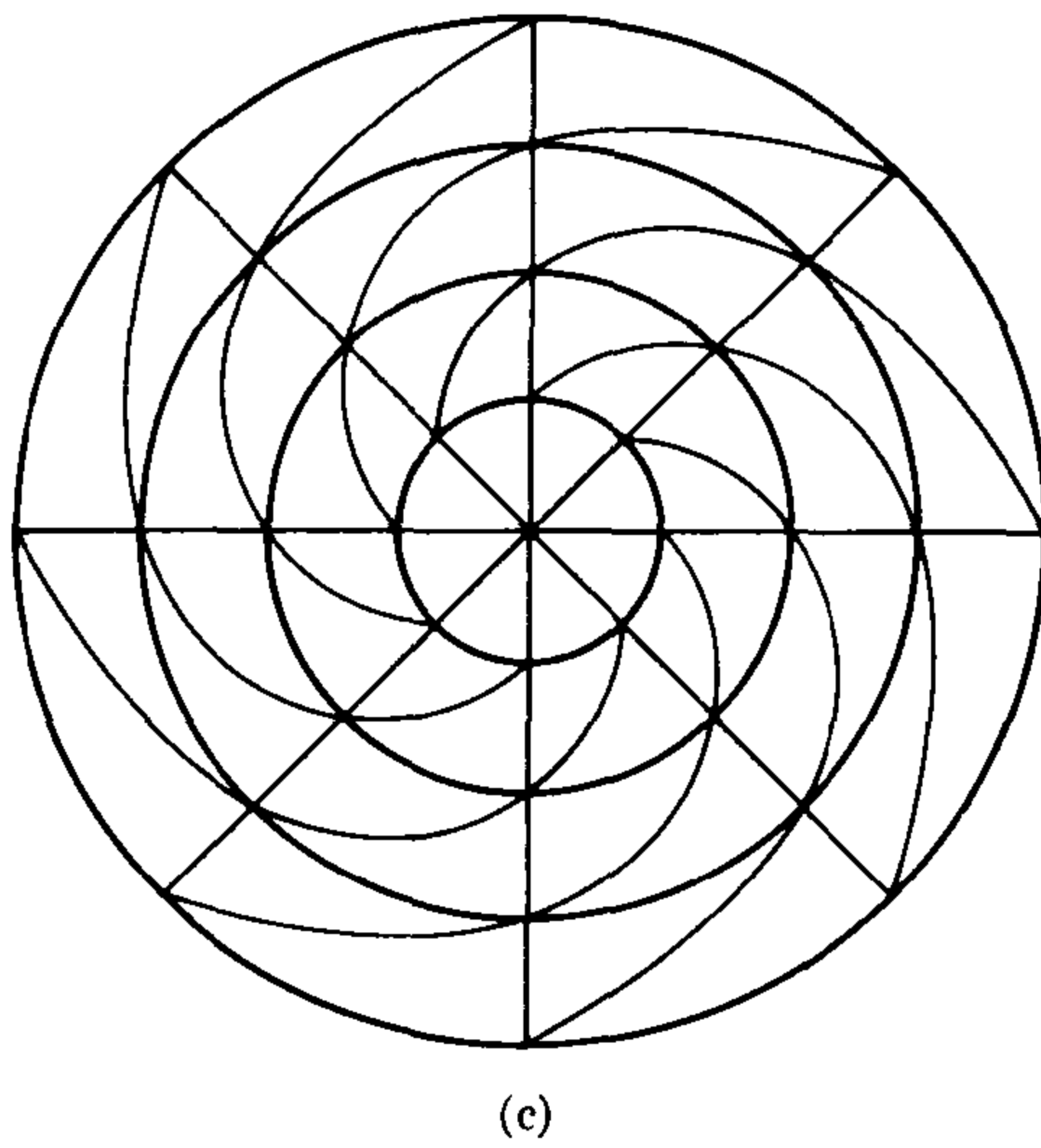
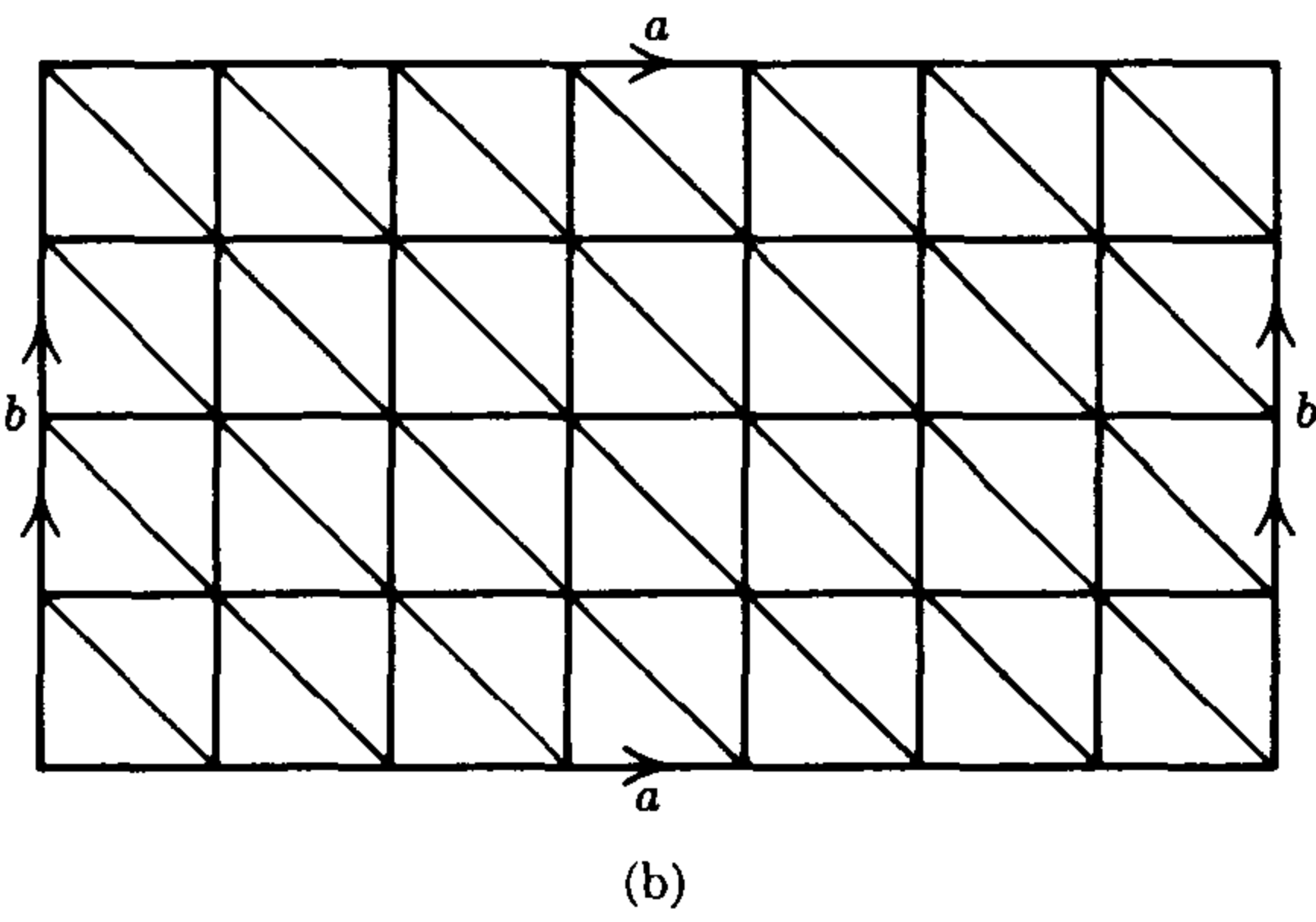
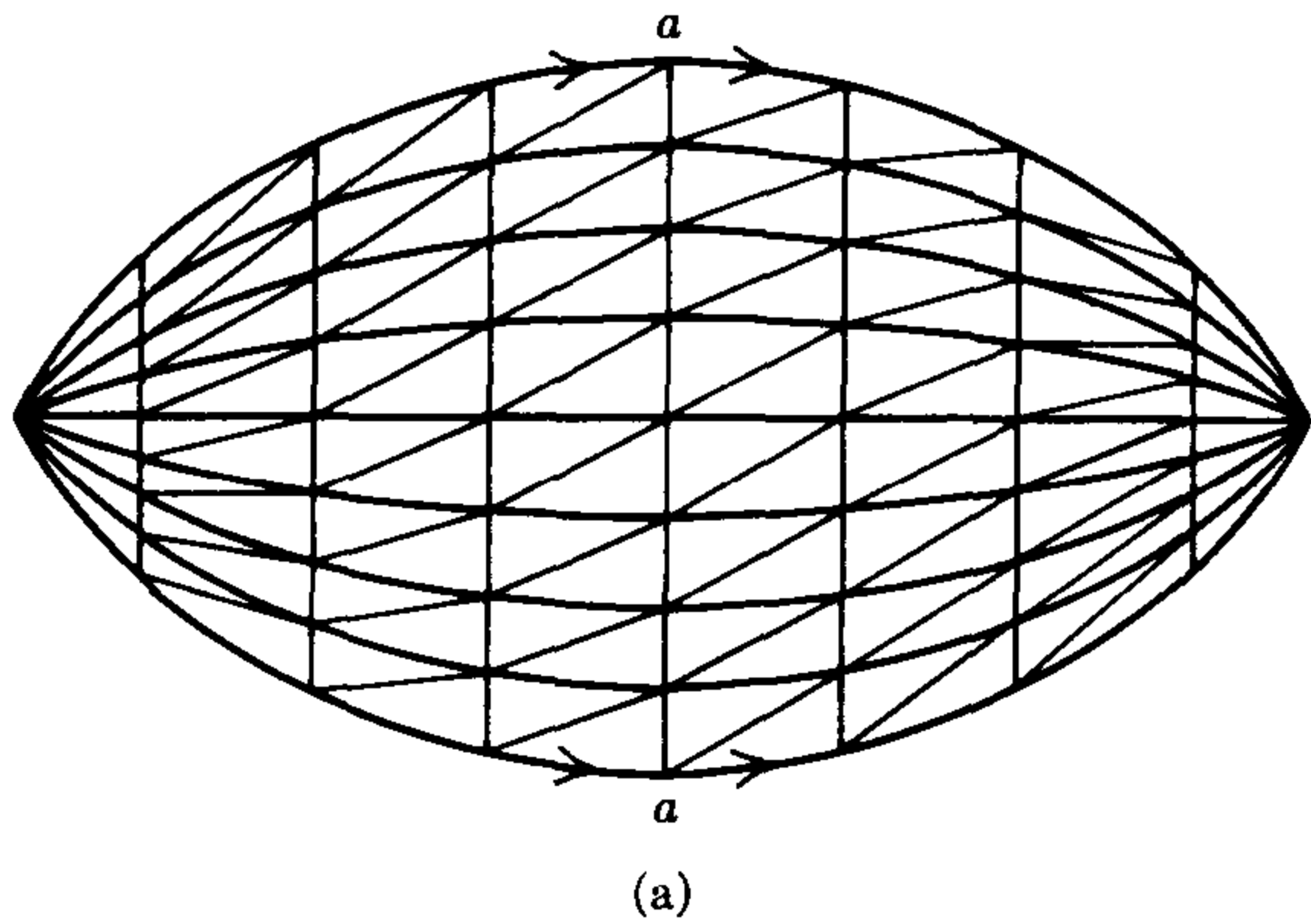

FIGURE 1.25. Computing the Euler characteristic from a triangulation. (a) Sphere. (b) Torus. (c) Projective plane.

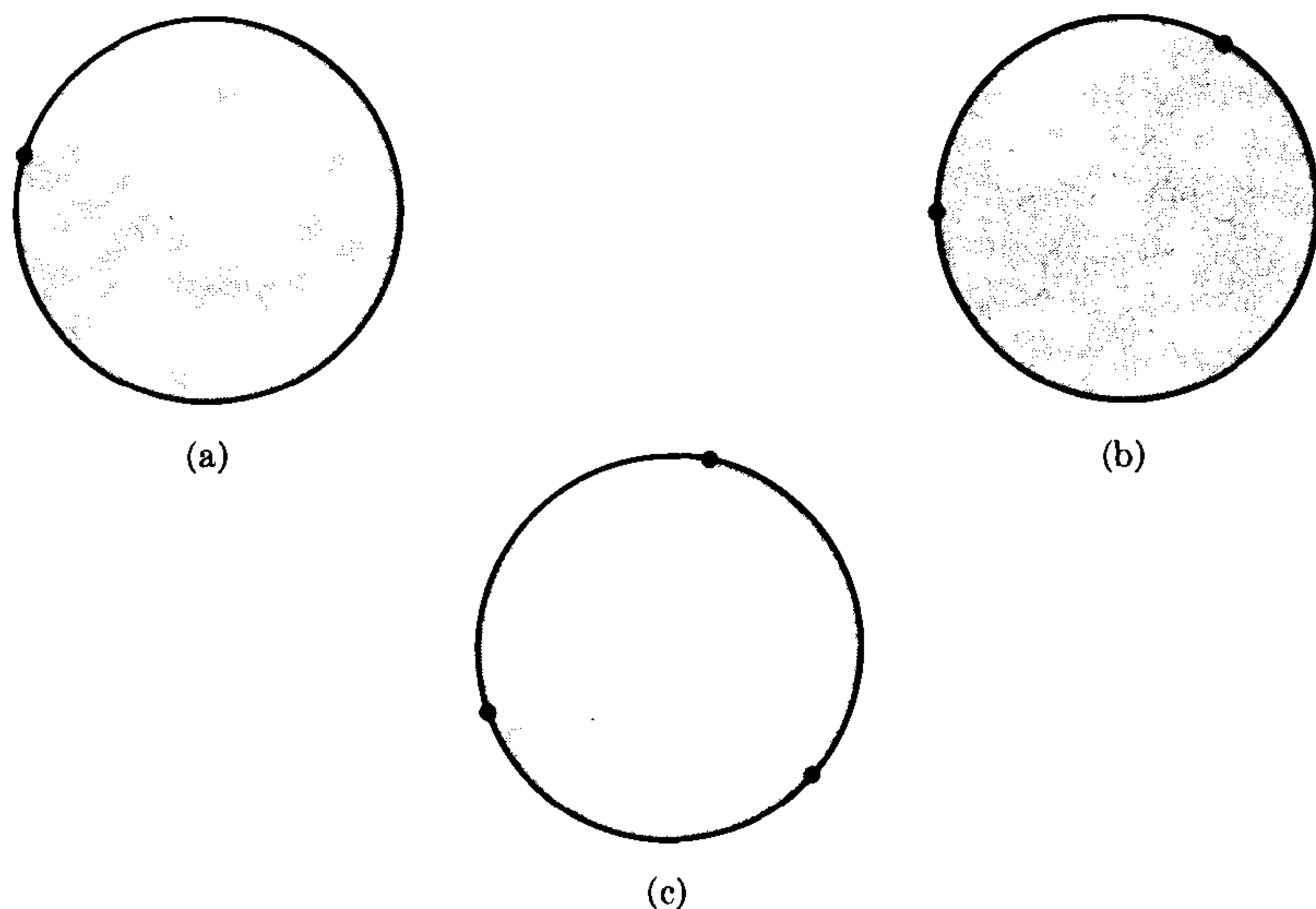

FIGURE 1.26. (a) 1-gon. (b) A 2-gon. (c) A 3-gon.

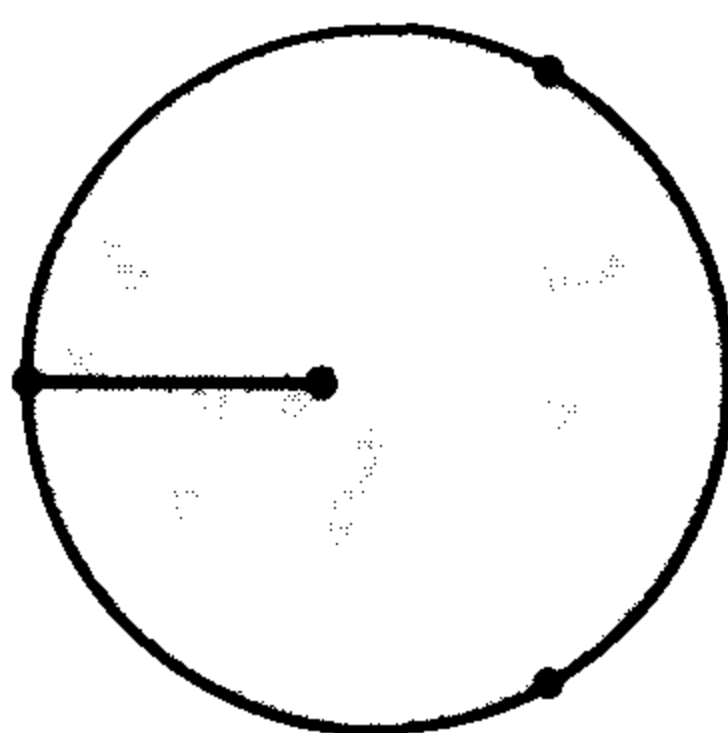

FIGURE 1.27. An allowable kind of edge.

for the sphere and torus, and of the number of radial lines or concentric circles in the case of the diagram for the projective plane.

Consideration of these and other examples suggests that $\chi(M)$ depends only on M , not on the triangulation chosen. We wish to suggest a method of proving this. To do this, we shall allow subdivisions of M into arbitrary polygons, not just triangles. These polygons may have any number n of sides and vertices, $n \geq 1$ (see Figure 1.26). We shall also allow for the possibility of edges that do not subdivide a region, as in Figure 1.27. In any case, the interior of each polygonal region is required to be homeomorphic to an open disc, and each edge is required to be homeomorphic to an open interval of the real line, once the vertices are removed (the closure of each edge shall be homeomorphic to a closed interval or a circle). Finally, the number of vertices, edges, and polygonal regions will be finite. As before, we define the Euler characteristic

of such a subdivision of a compact surface M to be

$$\chi(M) = (\text{No. of vertices}) - (\text{No. of edges}) + (\text{No. of regions}).$$

It is now easily shown that the Euler characteristic is invariant under the following processes:

- (a) Subdividing an edge by adding a new vertex at an interior point (or, inversely, if only two edges meet at a given vertex, we can amalgamate the two edges into one and eliminate the vertex).
- (b) Subdividing an n -gon, $n \geq 1$, by connecting two of the vertices by a new edge (or, inversely, amalgamating two regions into one by removing an edge).
- (c) Introducing a new edge and vertex running into a region, as shown in Figure 1.27 (or, inversely, eliminating such an edge and vertex).

The invariance of the Euler characteristic would now follow if it could be shown that we could get from any one triangulation (or subdivision) to any other by a finite sequence of “moves” of types (a), (b), and (c). Suppose we have two triangulations

$$\mathcal{T} = \{T_1, T_2, \dots, T_m\},$$

$$\mathcal{T}' = \{T'_1, T'_2, \dots, T'_n\}$$

of a given surface. If the intersection of any edge of the triangulation \mathcal{T} with any edge of the triangulation \mathcal{T}' consists of a finite number of points and a finite number of closed intervals, then it is easily seen that we can get from the triangulation \mathcal{T} to the triangulation \mathcal{T}' in a finite number of such moves; the details are left to the reader. However, it may happen that an edge of \mathcal{T} intersects an edge of \mathcal{T}' in an infinite number of points, like the following two curves in the xy plane:

$$\{(x, y) : y = 0 \quad \text{and} \quad -1 \leq x \leq +1\},$$

$$\left\{ (x, y) : y = x \sin \frac{1}{x} \quad \text{and} \quad 0 < |x| \leq 1 \right\} \cup \{(0, 0)\}.$$

If this is the case, it is clearly impossible to get from the triangulation \mathcal{T} to the triangulation \mathcal{T}' by any finite number of moves. It appears plausible that we could always avoid such a situation by “moving” one of the edges slightly. This is true and can be proved rigorously. However, we do not attempt such a proof here for several reasons: (a) The details are tedious and involved. (b) In Chapter IX we will define the Euler characteristic for a more general class of topological spaces and prove its invariance by means of homology theory. In these more general circumstances, the type of proof we have suggested here is not possible. (c) We will use the Euler characteristic to distinguish between compact surfaces. We will achieve this purpose with complete rigor in later chapters by the use of the fundamental group and by use of homology groups.

Proposition 8.1. *Let S_1 and S_2 be compact surfaces. The Euler characteristics of S_1 and S_2 and their connected sum, $S_1 \# S_2$, are related by the formula*

$$\chi(S_1 \# S_2) = \chi(S_1) + \chi(S_2) - 2.$$

PROOF. The proof is very simple; assume S_1 and S_2 are triangulated. Form their connected sum by removing from each the interior of a triangle, and then identifying edges and vertices of the boundaries of the removed triangles. The formula then follows by counting vertices, edges, and triangles before and after the formation of the connected sum. Q.E.D.

Using this proposition, and an obvious induction, starting from the known results for the sphere, torus, and projective plane, we obtain the following values for the Euler characteristics of the various possible compact surfaces:

<i>Surface</i>	<i>Euler characteristic</i>
Sphere	2
Connected sum of n tori	$2 - 2n$
Connected sum of n projective planes	$2 - n$
Connected sum of projective plane and n tori	$1 - 2n$
Connected sum of Klein bottle and n tori	$-2n$

Note that the Euler characteristic of an orientable surface is always even, whereas for a nonorientable surface it may be either odd or even.

Assuming the topological invariance of the Euler characteristic and Theorem 5.1, we have the following important result:

Theorem 8.2. *Let S_1 and S_2 be compact surfaces. Then, S_1 and S_2 are homeomorphic if and only if their Euler characteristics are equal and both are orientable or both are nonorientable.*

This is a topological theorem par excellence; it reduces the classification problem for compact surfaces to the determination of the orientability and Euler characteristic, both problems usually readily soluble. Moreover, Theorem 5.1 makes clear what are all possible compact surfaces.

Such a complete classification of any class of topological spaces is very rare. No corresponding theorem is known for compact 3-manifolds, and for 4-manifolds it has been proven (roughly speaking) that no such result is possible.

We close this section by giving some standard terminology. A surface that is the connected sum of n tori or n projective planes is said to be of *genus* n , whereas a sphere is of *genus* 0. The following relation holds between the genus g and the Euler characteristic χ of a compact surface:

$$g = \begin{cases} \frac{1}{2}(2 - \chi) & \text{in the orientable case} \\ 2 - \chi & \text{in the nonorientable case.} \end{cases}$$

EXERCISES

8.1. For over 2000 years it has been known that there are only five regular polyhedra, namely, the regular tetrahedron, cube, octahedron, dodecahedron, and icosahedron. Prove this by considering subdivisions of the sphere into n -gons (n fixed) such that exactly m edges meet at each vertex (m fixed, $m, n \geq 3$). Use the fact that $\chi(S^2) = 2$.

8.2. For any *triangulation* of a compact surface, show that

$$3t = 2e,$$

$$e = 3(v - \chi),$$

$$v \geq \frac{1}{2}(7 + \sqrt{49 - 24\chi}).$$

In the case of the sphere, projective plane, and torus, what are the minimum values of the numbers v , e , and t ? (Here, t , e , and v denote the number of triangles, edges, and vertices, respectively.)

8.3. In how many pieces do n great circles, no three of which pass through a common point, dissect a sphere?

8.4. (a) The sides of a regular octagon are identified in pairs in such a way as to obtain a compact surface. Prove that the Euler characteristic of this surface is ≥ -2 .

(b) Prove that any surface (orientable or nonorientable) of Euler characteristic ≥ -2 can be obtained by suitably identifying in pairs the sides of a regular octagon.

8.5. Prove that it is not possible to subdivide the surface of a sphere into regions, each of which has six sides (i.e., it is a hexagon) and such that distinct regions have no more than one side in common.

8.6. Let S_1 be a surface that is the sum of m tori, $m \geq 1$, and let S_2 be a surface that is the sum of n projective planes, $n \geq 1$. Suppose two holes are cut in each of these surfaces, and the two surfaces are then glued together along the boundaries of the holes. What surface is obtained by this process?

8.7. What surface is represented by a regular 10-gon with edges identified in pairs, as indicated by the symbol $abcdec^{-1}da^{-1}b^{-1}e^{-1}$? (HINT: How are the vertices identified around the boundary?)

8.8. What surface is represented by a $2n$ -gon with the edges identified in pairs according to the symbol

$$a_1 a_2 \dots a_n a_1^{-1} a_2^{-1} \dots a_{n-1}^{-1} a_n?$$

8.9. What surface is represented by a $2n$ -gon with the edges identified in pairs according to the symbol

$$a_1 a_2 \dots a_n a_1^{-1} a_2^{-1} \dots a_{n-1}^{-1} a_n^{-1}?$$

(HINT: The cases where n is odd and where n is even are different.)

Remark: The results of Exercises 8.8 and 8.9 together give an alternative “normal form” for the representation of a compact surface as a quotient space of polygon.

NOTES

Definition of the connected sum of two manifolds

The definition of the connected sum given in §4 is adequate for 2-dimensional manifolds, but more care is necessary when we define the connected sum of two orientable n -manifolds for $n > 2$. We must worry about whether the homeomorphism h in our definition preserves or reverses orientations. The essential reason for this difference is that any orientable surface admits an orientation-reversing self-homeomorphism, whereas there exist orientable manifolds in higher dimensions which do not admit such a self-homeomorphism. Seifert and Threlfall ([6], pp. 290–291) give an example of a 3-dimensional manifold with this property. The complex projective plane is a 4-dimensional manifold having the property in question.

Triangulation of manifolds

In the early days of topology, it was apparently taken for granted that all surfaces and all higher-dimensional manifolds could be triangulated. The first rigorous proof that surfaces can be triangulated was published by Tibor Radó in a paper on Riemann surfaces [7]. Radó pointed out the necessity of assuming the surface has a countable basis for its topology and gave an example (due to Prüfer) of a surface that does not have such a countable basis. Radó's proof, given in Chapter I of the text by Ahlfors and Sario [1], makes essential use of a strong form of the Jordan Curve Theorem. The triangulability of 3-manifolds was proved by E. Moise (Affine Structures in 3-manifolds, V: The triangulation theorem and Hauptvermutung. *Ann. Math.* **56** (1952), 96–114).

Recent results of A. Casson and M. Freedman show that some 4-dimensional manifolds cannot be triangulated.

Models of nonorientable surfaces in Euclidean 3-space

No closed subset of Euclidean n -space is homeomorphic to a nonorientable $(n - 1)$ -manifold. This result, first proved by the Dutch mathematician L.E.J. Brouwer in 1912, can now be proved as an easy corollary of some general theorems of homology theory. This fact seriously hampers the development of our geometric intuition regarding compact, nonorientable surfaces, since they cannot be imbedded homeomorphically in Euclidean 3-space. However, it is possible to construct models of such surfaces in Euclidean 3-space provided we allow "singularities" or "self-intersections." We can even construct a mathematical theory of such models by considering the concept of *immersion* of manifolds. We say that a continuous map f of a compact n -manifold M^n into m -dimensional Euclidean space \mathbf{R}^m is a *topological immersion* if each point

of M^n has a neighborhood mapped homeomorphically onto its image by f . (The definition of a *differentiable immersion* is analogous; f is required to be differentiable and have a Jacobian everywhere of maximal rank.) The usual model of a Klein bottle in \mathbf{R}^3 is an immersion of the Klein bottle in 3-space. Werner Boy, in his thesis at the University of Göttingen in 1901 [Über die Abbildung der projektiven Ebene auf eine im Endlichen geschlossene singularitätenfreie Fläche. *Nach. Königl. Gesell. Wiss. Göttingen (Math. Phys. Kl.)*, 1901, pp. 20–33. See also *Math. Ann.* **57** (1903), 173–184], constructed immersions of the projective plane in \mathbf{R}^3 . One of the immersions given by Boy is reproduced in Hilbert and Cohn-Vossen [3]. Since any compact, non-orientable surface is homeomorphic to the connected sum of an orientable surface and a projective plane or a Klein bottle, it is now easy to construct immersions of the remaining compact, nonorientable surfaces in \mathbf{R}^3 .

The usual immersion of the Klein bottle in \mathbf{R}^3 is much nicer than any of the immersions of the projective plane given by Boy. The set of singular points for the immersion of the Klein bottle consists of a circle of double points, whereas the set of singular points for Boy's immersions of the projective plane is much more complicated. This raises the question, does there exist an immersion of the projective plane in \mathbf{R}^3 such that the set of singular points consists of disjoint circles of double points? The answer to this question is negative, at least in the case of differentiable immersions; for the proof, see the two papers by T. Banchoff in *Proceedings of the American Mathematical Society* published in 1974 (**46**, 402–413).

For further information on the immersion of compact surfaces in \mathbf{R}^3 , see the interesting article entitled "Turning a Surface Inside Out" by Anthony Phillips in *Scientific American* published in 1966 (**214**, 112–120).

Bibliographical notes

The first proof of the classification theorem for compact surfaces is ascribed by some to H. R. Brahana (*Ann. Math.* **23** (1922), 144–68). However, Seifert and Threlfall ([6], p. 322), attribute it to Dehn and Heegard and do not even list Brahana's paper in their bibliography. During the 19th century several mathematicians worked on the classification of surfaces, especially at the time of Riemann and afterword. The nonexistence of any algorithm for the classification of compact triangulable 4-manifolds is a result of the Russian mathematician A. A. Markov (*Proc. Int. Cong. Mathematicians*, 1958, pp. 300–306). For the use of the Euler characteristic to prove the 5-color theorem for maps, see R. Courant and H. Robbins, *What Is Mathematics?* (Oxford University Press, New York, 1941, pp. 264–267). We also refer the student to excellent drawings in the books by Cairns ([2], p. 28), and Hilbert and Cohn-Vossen ([3], p. 265), illustrating how the connected sum of two or three tori can be cut open to obtain a polygon whose opposite edges are to be identified in pairs.

References

Books

1. L. V. Ahlfors and L. Sario, *Riemann Surfaces*, Princeton University Press, Princeton, N.J., 1960, Chapter I.
2. S. S. Cairns, *Topology*, Ronald, New York, 1961, Chapter II.
3. D. Hilbert and S. Cohn-Vossen, *Anschauliche Geometrie*, Dover, New York, 1944. Chapter VI. There is also an English translation by P. Nemenyi entitled *Geometry and the Imagination*, Chelsea, New York, 1956.
4. B. Kerekjarto, *Vorlesungen über Topologie*, J. Springer, Berlin, 1923, Chapters IV and V.
5. K. Reidemeister, *Einführung in die kombinatorische Topologie*, Friedr. Vieweg & Sohn, Braunschweig, 1932, Chapter V.
6. H. Seifert and W. Threlfall, *A Textbook of Topology*, Academic Press, New York, 1980, Chapter 6.

Papers

7. T. Radó, Über den Begriff der Riemannschen Fläche. *Acta Litt. Sci. Szeged.* **2** (1925), 101–121.
8. I. Richards, On the classification of noncompact surfaces, *Trans. Am. Math. Soc.* **106** (1963), 259–269.
9. P. H. Doyle and D. A. Moran. A short proof that compact 2-manifolds can be triangulated, *Invent. Math.* **5** (1968), 160–162.

CHAPTER II

The Fundamental Group

§1. Introduction

For any topological space X and any point $x_0 \in X$, we will define a group, called *the fundamental group* of X , and denoted by $\pi(X, x_0)$. (Actually, the choice of the point x_0 is usually of minor importance, and hence it is often omitted from the notation.) We define this group by a very simple and intuitive procedure involving the use of closed paths in X . From the definition, it will be clear that the group is a topological invariant of X ; i.e., if two spaces are homeomorphic, their fundamental groups are isomorphic. This gives us the possibility of proving that two spaces are not homeomorphic by proving that their fundamental groups are nonisomorphic. For example, this method suffices to distinguish between the various compact surfaces and in many other cases.

Now only does the fundamental group give information about spaces, but it also is often useful in studying continuous maps. As we shall see, any continuous map from a space X into a space Y induces a homomorphism of the fundamental group of X into that of Y . Certain topological properties of the continuous map will be reflected in the properties of this induced homomorphism. Thus, we can prove facts about certain continuous maps by studying the induced homomorphism of the fundamental groups.

We can summarize the above two paragraphs as follows: By using the fundamental group, topological problems about spaces and continuous maps can sometimes be reduced to purely algebraic problems about groups and homomorphisms. This is the basic strategy of the entire subject of algebraic topology: to find methods of reducing topological problems to questions of pure algebra, and then hope that algebraists can solve the latter.

This chapter will only give the basic definition and properties of the fundamental group and induced homomorphism, and determine its structure for a few very simple spaces. In later chapters we shall develop more general methods for determining the fundamental groups of some more interesting spaces.

§2. Basic Notation and Terminology

As usual, for any real numbers a and b such that $a < b$, $[a, b]$ denotes the closed interval of the real line with a and b as end points. For conciseness, we set $I = [0, 1]$. We note that, given any two closed intervals $[a, b]$ and $[c, d]$, there exist unique *linear* homeomorphisms

$$h_1, h_0 : [a, b] \rightarrow [c, d],$$

such that

$$h_0(a) = c, \quad h_0(b) = d,$$

$$h_1(a) = d, \quad h_1(b) = c.$$

We distinguish between these two by calling h_0 *orientation preserving* and h_1 *orientation reversing*.

A *path* or *arc* in a topological space X is a continuous map of some closed interval into X . The images of the end points of the interval are called the *end points* of the path or arc, and the path is said to *join* its end points. One of the end points is called the *initial* point, the other is called the *terminal* point (it is clear which is which).

A space X is called *arcwise connected* or *pathwise connected* if any two points of X can be joined by an arc. An arcwise-connected space is connected, but the converse statement is not true. The *arc components* of X are the maximal arcwise-connected subsets of X (by analogy with the ordinary components of X). Note that the arc components of X need not be closed sets. A space is *locally arcwise connected* if each point has a basic family of arcwise-connected neighborhoods (by analogy with ordinary local connectivity).

EXERCISE

2.1. Prove that a space which is connected and locally arcwise connected is arcwise connected.

Definition. Let $f_0, f_1 : [a, b] \rightarrow X$ be two paths in X such that $f_0(a) = f_1(a)$, $f_0(b) = f_1(b)$ (i.e., the two paths have the same initial and terminal points). We say that these two paths are *equivalent*, denoted by $f_0 \sim f_1$, if and only if there exists a continuous map

$$f : [a, b] \times I \rightarrow X,$$

such that

$$\left. \begin{aligned} f(t, 0) &= f_0(t) \\ f(t, 1) &= f_1(t) \end{aligned} \right\} t \in [a, b],$$

$$\left. \begin{aligned} f(a, s) &= f_0(a) = f_1(a) \\ f(b, s) &= f_0(b) = f_1(b) \end{aligned} \right\} s \in I.$$

Note that in the above definition we could replace I by any other closed interval if necessary. We leave it as an exercise to verify that this relation is reflexive, symmetric, and transitive.

Intuitively we say that two paths are equivalent if one can be continuously deformed into the other in the space X . During the deformation, the end points must remain fixed.

Our second basic definition is that of the *product* of two paths. The product of two paths is only defined if the terminal point of the first path is the initial point of the second path. If this condition holds, the product path is traversed by traversing the first path and then the second path, in the given order. To be precise, assume

$$\begin{aligned} f &: [a, b] \rightarrow X, \\ g &: [b, c] \rightarrow X \end{aligned}$$

are paths such that $f(b) = g(b)$ (here $a < b < c$). Then the product $f \cdot g$ is defined by

$$(f \cdot g)t = \begin{cases} f(t), & t \in [a, b] \\ g(t), & t \in [b, c]. \end{cases} \quad (2.2.1)$$

It is a map $[a, c] \rightarrow X$. In the above definition, we had the rather cumbersome requirement that the domains of f and g had to be the intervals $[a, b]$ and $[b, c]$, respectively. We can remove this requirement by changing the domain of f or g by means of an orientation-preserving linear homeomorphism. Actually, in the future we shall only be interested in equivalence classes of paths rather than the paths themselves. By “equivalence class,” we mean, with respect to the equivalence relation defined above and also with respect to the following obvious equivalence relation: If $f : [a, b] \rightarrow X$ and $g : [c, d] \rightarrow X$ are paths such that $g = fh$, where $h : [c, d] \rightarrow [a, b]$ is an *orientation-preserving* linear homeomorphism, then f and g are to be regarded as equivalent. Rather than considering paths whose domain is an arbitrary closed interval and allowing orientation-preserving linear homeomorphisms between any two such intervals, we find it technically simpler to demand that all paths be functions defined on one fixed interval, namely, the interval $I = [0, 1]$. As a result of this simplification, the simple formula for the product of two paths, (2.2.1), has to be replaced by a more complicated formula. Also, it will not be immediately obvious that the multiplication of path classes is associative. However, the reader should keep in mind that there are various alternative ways of proceeding with this subject.

§3. Definition of the Fundamental Group of a Space

From now on, by a *path in X* we mean a continuous map $I \rightarrow X$. If f and g are paths in X such that the terminal point of f is the initial point of g , then the product $f \cdot g$ is defined by

$$(f \cdot g)t = \begin{cases} f(2t), & 0 \leq t \leq \frac{1}{2} \\ g(2t - 1), & \frac{1}{2} \leq t \leq 1. \end{cases}$$

We say two paths, f_0 and f_1 , are *equivalent* ($f_0 \sim f_1$) if the condition in §2 is satisfied.

Lemma 3.1. *The equivalence relation and the product we have defined are compatible in the following sense: If $f_0 \sim f_1$ and $g_0 \sim g_1$, then $f_0 \cdot g_0 \sim f_1 \cdot g_1$ (it is assumed, of course, that the terminal point of f_0 is the initial point of g_0).*

The proof may be left to the reader. In proving lemmas such as this, the following fact is often useful: *Let A and B be closed subsets of the topological space X such that $X = A \cup B$. If f is a function defined on X such that the restrictions $f|_A$ and $f|_B$ are both continuous, then f is continuous.* The proof, which is easy, is left to the reader. In the future, we will use this fact without comment.

As a result of Lemma 3.1, the multiplication of paths defines a multiplication of equivalence classes of paths (provided the terminal point of the first path and the initial point of the second path coincide). It is this multiplication of equivalence classes with which we are primarily concerned. Note that the multiplication of paths is not associative in general, i.e., $(f \cdot g) \cdot h \neq f \cdot (g \cdot h)$ (we assume both products are defined). However, we have

Lemma 3.2. *The multiplication of equivalence classes of paths is associative.*

PROOF. It suffices to prove the following: Let f , g , and h be paths such that the terminal point of $f =$ initial point of g , and the terminal point of $g =$ initial point of h . Then

$$(f \cdot g) \cdot h \sim f \cdot (g \cdot h).$$

To prove this, consider the function $F : I \times I \rightarrow X$ defined by

$$F(t, s) = \begin{cases} f\left(\frac{4t}{1+s}\right), & 0 \leq t \leq \frac{s+1}{4} \\ g(4t - 1 - s), & \frac{s+1}{4} \leq t \leq \frac{s+2}{4} \\ h\left(1 - \frac{4(1-t)}{2-s}\right), & \frac{s+2}{4} \leq t \leq 1. \end{cases}$$

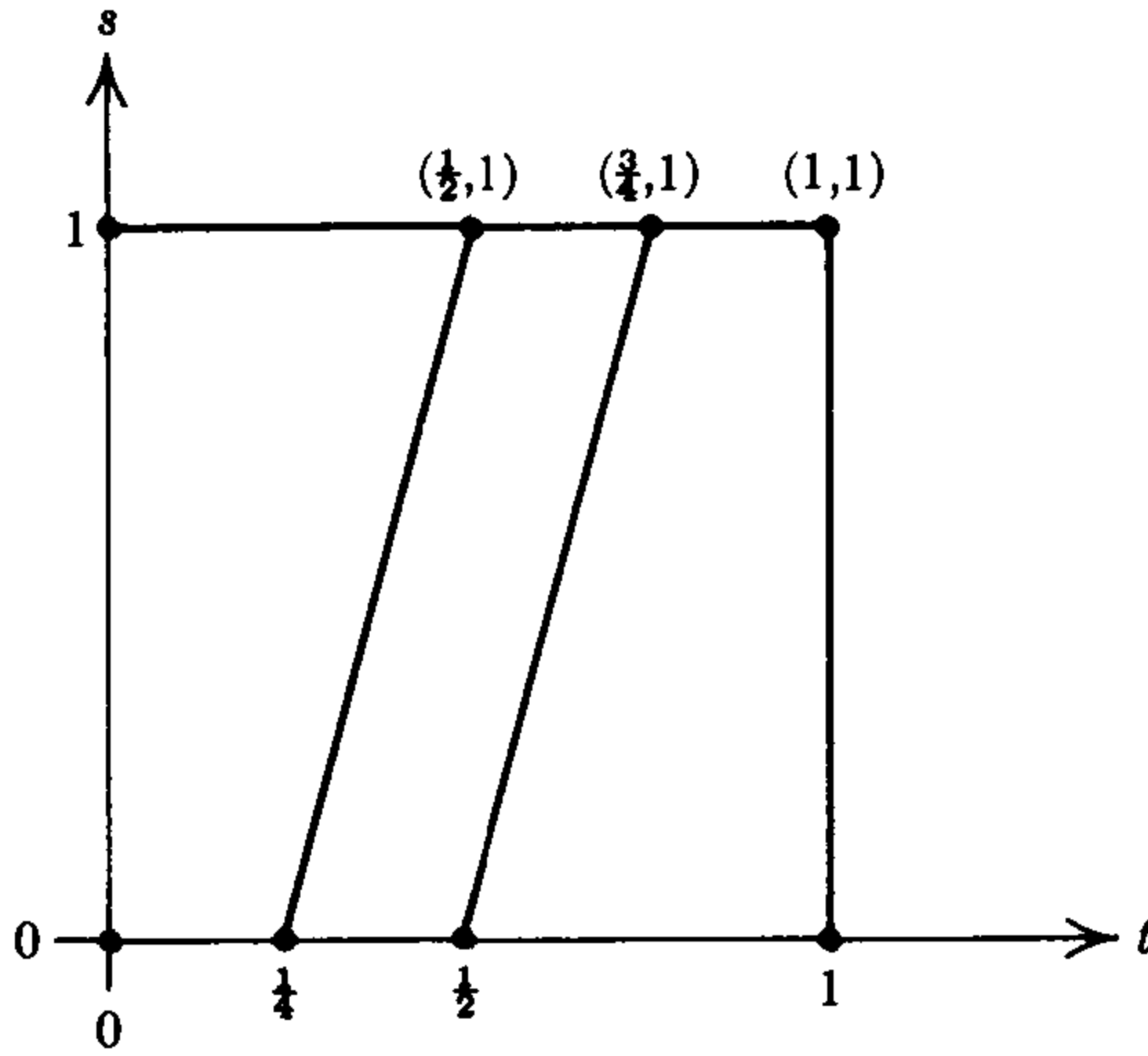

FIGURE 2.1. Proof of associativity.

Then, F is continuous, $F(t, 0) = [(f \cdot g) \cdot h]t$, and $F(t, 1) = [f \cdot (g \cdot h)]t$. The motivation for the definition of F is given in Figure 2.1. Q.E.D.

For any point $x \in X$, let us denote by \mathcal{E}_x the equivalence class of the constant map of I into the point x of X . This path class has the following fundamental property:

Lemma 3.3. *Let α be an equivalence class of paths with initial point x and terminal point y . Then $\mathcal{E}_x \cdot \alpha = \alpha$ and $\alpha \cdot \mathcal{E}_y = \alpha$.*

PROOF. Let $e : I \rightarrow X$ be the constant map such that $e(I) = \{x\}$ and let $f : I \rightarrow X$ be a representative of the path class α . To prove the first relation, it suffices to prove that $e \cdot f \sim f$. Define $F : I \times I \rightarrow X$ by

$$F(t, s) = \begin{cases} x, & 0 \leq t \leq \frac{1}{2}s \\ f\left(\frac{2t - s}{2 - s}\right), & \frac{1}{2}s \leq t \leq 1. \end{cases}$$

Then $F(t, 0) = f(t)$ and $F(t, 1) = (e \cdot f)t$ as required. The motivation for the definition of F is shown in Figure 2.2. The proof that $\alpha \cdot \mathcal{E}_y = \alpha$ is similar and is left to the reader. Q.E.D.

For any path $f : I \rightarrow X$, let \bar{f} denote the path defined by

$$\bar{f}(t) = f(1 - t), \quad t \in I.$$

The path \bar{f} is obtained by traversing the path f in the opposite direction.

Lemma 3.4 *Let α and $\bar{\alpha}$ denote the equivalence classes of the paths f and \bar{f} , respectively. Then,*

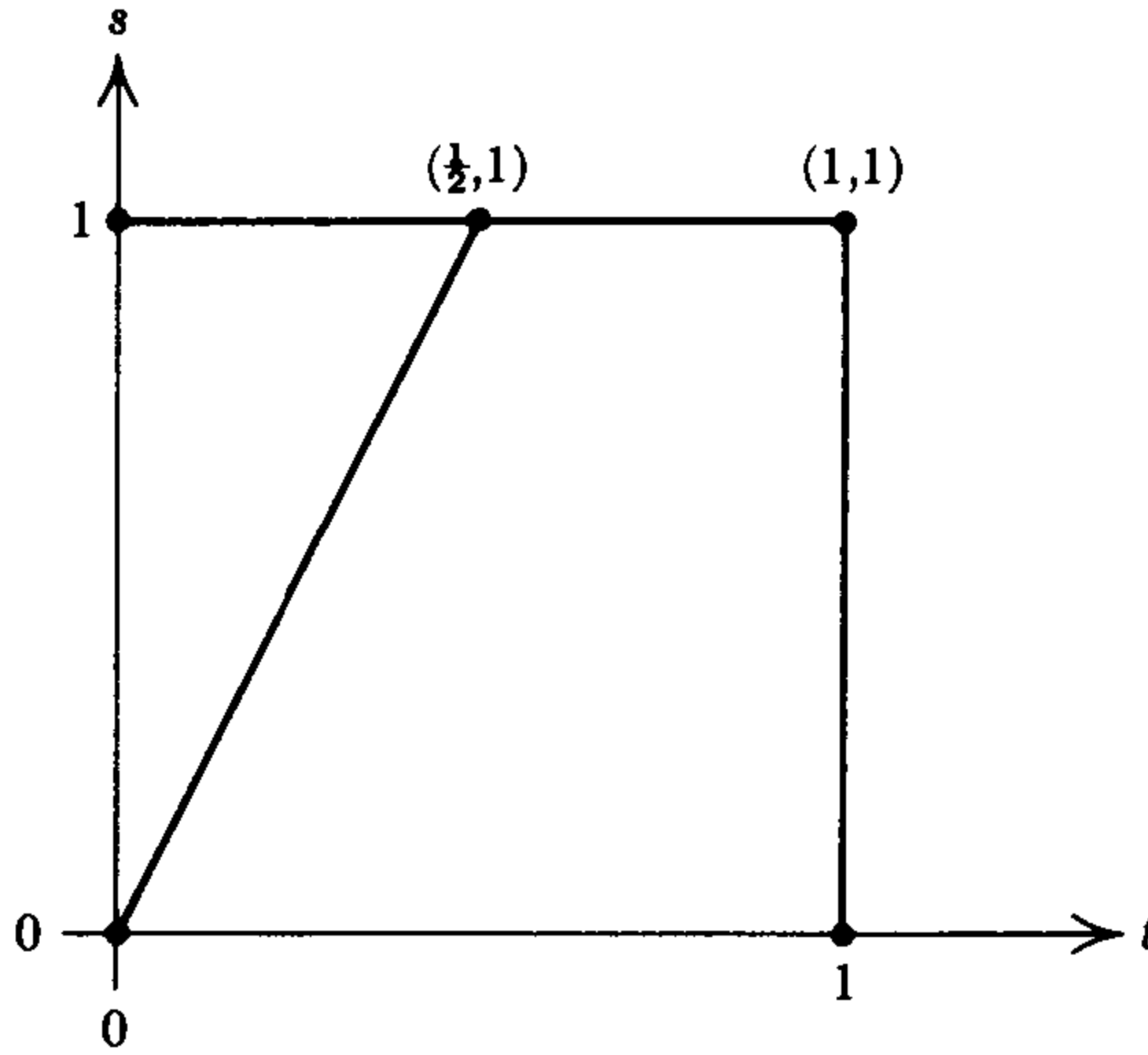

FIGURE 2.2. Proof of existence of units.

$$\alpha \cdot \bar{\alpha} = \mathcal{E}_x, \quad \bar{\alpha} \cdot \alpha = \mathcal{E}_y,$$

where x and y are the initial and terminal points of the path f .

PROOF. To prove the first equation, it suffices to show that $f \cdot \bar{f} \sim e$, where e is the constant path at the point x . Therefore, we define $F : I \times I \rightarrow X$ by

$$F(t, s) = \begin{cases} f(2t), & 0 \leq t \leq \frac{1}{2}s \\ f(s), & \frac{1}{2}s \leq t \leq 1 - \frac{1}{2}s \\ f(2 - 2t), & 1 - \frac{1}{2}s \leq t \leq 1. \end{cases}$$

We then see that $F(t, 0) = x$, whereas $(f \cdot \bar{f})t = F(t, 1)$. Figure 2.3 explains the choice of the function F . We can also motivate the deformation of the path

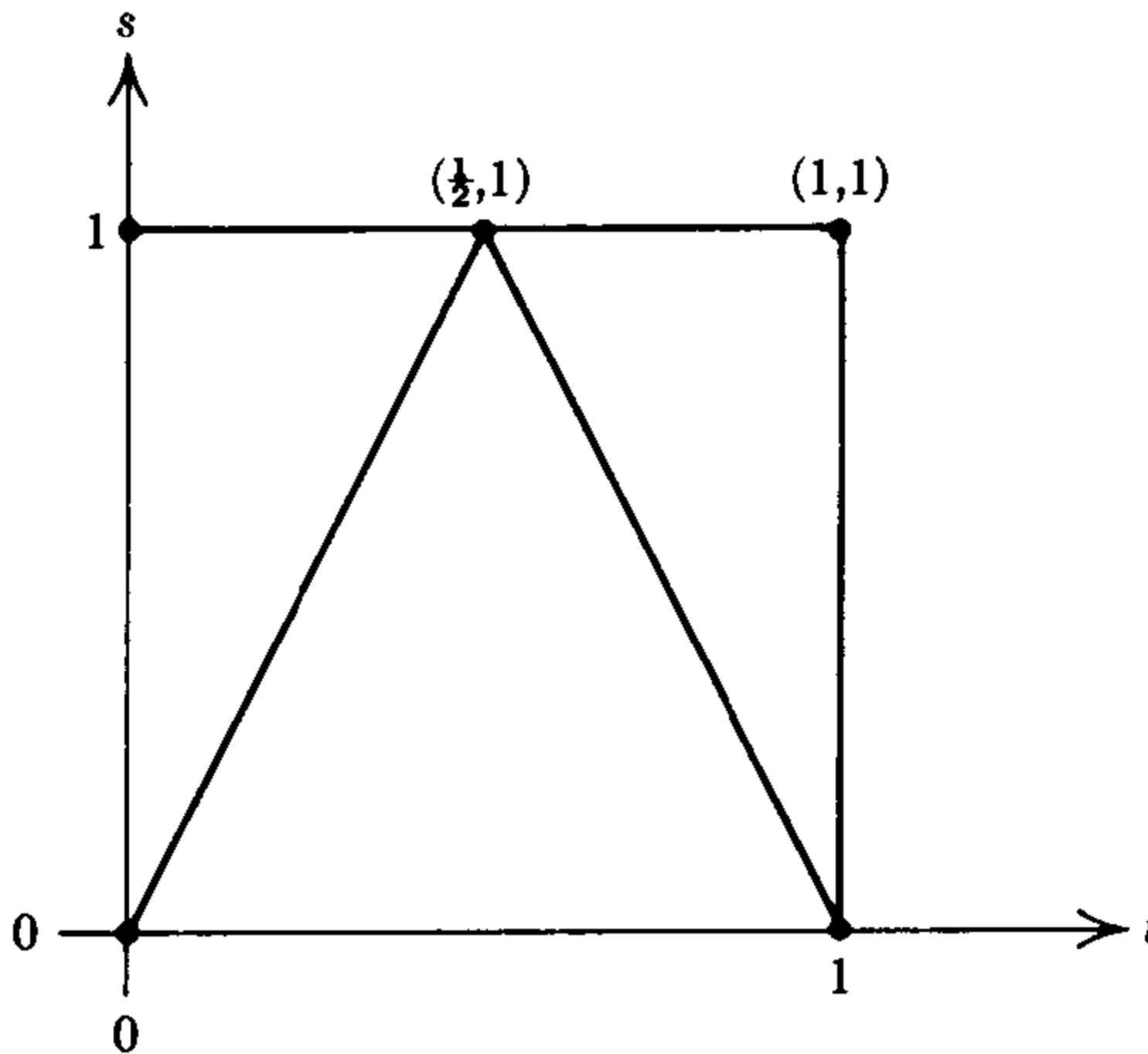

FIGURE 2.3. Proof of existence of inverses.

$f \cdot \bar{f}$ into the constant path e by a simple mechanical analogy. Consider the path f as an elastic “thread” in the space X from the point x to y ; then \bar{f} is another “thread” in the opposite direction, from y to x , and $f \cdot \bar{f}$ is represented by joining the two threads at the point y . We can now “pull in” the doubled thread to the point x because we do not need to keep it attached to the point y .

The proof that $\bar{\alpha} \cdot \alpha = \mathcal{E}_y$ is similar and is left to the reader. Q.E.D.

In view of these properties of the path class $\bar{\alpha}$, from now on we will denote it by α^{-1} . It is readily seen that the conditions of the lemma just proved characterize α^{-1} uniquely. Hence, if $f_0 \sim f_1$, then $\bar{f}_0 \sim \bar{f}_1$.

We can summarize the lemmas just proved by saying that the set of all path classes in X satisfies the axioms for a group, except that the product of two paths is not always defined.

Definition. A path, or path class, is called *closed*, or a *loop*, if the initial and terminal points are the same. The loop is said to be *based* at the common end point.

Let x be any point of X ; it is readily seen that the set of all loops based at x is a group. This group is called the *fundamental group* or *Poincaré group* of X at the base point x and is denoted by $\pi(X, x)$.

Next, we will investigate the dependence of the group $\pi(X, x)$ on the base point x . Let x and y be two points in X , and let γ be a path class with initial point x and terminal point y (hence, x and y belong to the same component of X). Using the path γ , we define a mapping $u: \pi(X, x) \rightarrow \pi(X, y)$ by the formula $\alpha \rightarrow \gamma^{-1}\alpha\gamma$. We see immediately that this mapping is a homomorphism of $\pi(X, x)$ into $\pi(X, y)$. By using the path γ^{-1} instead of γ , we can define a homomorphism $v: \pi(X, y) \rightarrow \pi(X, x)$ in a similar manner. We immediately verify that the composed homomorphisms vu and uv are the identity maps of $\pi(X, x)$ and $\pi(X, y)$, respectively. Thus, u and v are isomorphisms, each of which is the inverse of the other. Thus, we have proved

Theorem. 3.5. *If X is arcwise connected, the groups $\pi(X, x)$ and $\pi(X, y)$ are isomorphic for any two points $x, y \in X$.*

The importance of this theorem is obvious; e.g., the question as to whether or not $\pi(X, x)$ has any given group theoretic property (e.g., it is abelian, finite, nilpotent, free, etc.) is independent of the point x , and thus depends only on the space X , provided X is arcwise connected.

On the other hand, we must keep in mind that there is no *canonical* or *natural* isomorphism between $\pi(X, x)$ and $\pi(X, y)$; corresponding to each choice of a path class from x to y there will be an isomorphism, from $\pi(X, x)$ to $\pi(X, y)$, and, in general, different path classes will give rise to different isomorphisms.

EXERCISES

- 3.1. Under what conditions will two path classes, γ and γ' , from x to y give rise to the same isomorphism of $\pi(X, x)$ onto $\pi(X, y)$?
- 3.2. Let X be an arcwise-connected space. Under what conditions is the following statement true: For any two points $x, y \in X$, all path classes from x to y give rise to the same isomorphism of $\pi(X, x)$ onto $\pi(X, y)$?
- 3.3. Let $f, g: I \rightarrow X$ be two paths with initial point x_0 and terminal point x_1 . Prove that $f \sim g$ if and only if $f \cdot \bar{g}$ is equivalent to the constant path at x_0 (\bar{g} is defined as in Lemma 3.4).

We will actually determine the structure of the fundamental group of various spaces later in this chapter and in Chapter IV.

§4. The Effect of a Continuous Mapping on the Fundamental Group

Let $\varphi: X \rightarrow Y$ be a continuous mapping, and let $f_0, f_1: I \rightarrow X$ be paths in X . It is readily seen that if f_0 and f_1 are equivalent, then so are the paths φf_0 and φf_1 represented by the composed functions. Thus, if α denotes the path class that contains f_0 and f_1 , it makes sense to denote by $\varphi_*(\alpha)$ the path class that contains the paths φf_0 and φf_1 . $\varphi_*(\alpha)$ is the image of the path class α in the space Y , and it is readily verified that the mapping φ_* which sends α into $\varphi_*(\alpha)$ has the following properties:

- (a) If α and β are path classes in X such that $\alpha \cdot \beta$ is defined, then $\varphi_*(\alpha \cdot \beta) = (\varphi_*\alpha) \cdot (\varphi_*\beta)$.
- (b) For any point $x \in X$, $\varphi_*(\mathcal{E}_x) = \mathcal{E}_{\varphi(x)}$.
- (c) $\varphi_*(\alpha^{-1}) = (\varphi_*\alpha)^{-1}$.

For these reasons, we shall call φ_* a "homomorphism," or, the "homomorphism induced by φ ."

If $\psi: Y \rightarrow Z$ is also a continuous map, then we can verify the following property easily:

- (d) $(\psi\varphi)_* = \psi_*\varphi_*$.

Finally, if $\varphi: X \rightarrow X$ is the identity map, then

- (e) $\varphi_*(\alpha) = \alpha$ for any path class α in X ; i.e., φ_* is the identity homomorphism.

Note that, in view of these properties, a continuous map $\varphi: X \rightarrow Y$ induces a homomorphism $\varphi_*: \pi(X, x) \rightarrow \pi(Y, \varphi(x))$; and, if φ is a homeomorphism, then φ_* is an isomorphism. This induced homeomorphism will be extremely important in studying the fundamental group.

Caution: If φ is a one-to-one map, it does *not* follow that φ^* is one-to-one; similarly, if φ is onto, it does not follow that φ_* is onto. We shall see examples to illustrate this point later.

EXERCISE

4.1. Let $\varphi : X \rightarrow Y$ be a continuous map and let γ be a class of paths in X from x_0 to x_1 . Prove that the following diagram is commutative:

$$\begin{array}{ccc} \pi(X, x_0) & \xrightarrow{\varphi_*} & \pi(Y, \varphi(x_0)) \\ \downarrow u & & \downarrow v \\ \pi(X, x_1) & \xrightarrow{\varphi_*} & \pi(Y, \varphi(x_1)). \end{array}$$

Here the isomorphism u is defined by $u(\alpha) = \gamma^{-1}\alpha\gamma$, and v is defined similarly using $\varphi_*(\gamma)$ in place of γ . [NOTE: An important special case occurs if $\varphi(x_0) = \varphi(x_1)$. Then, $\varphi_*(\gamma)$ is an element of the group $\pi(Y, \varphi(x_0))$.]

To make further progress in the study of the induced homomorphism φ_* , we must introduce the important notion of *homotopy* of continuous maps.

Definition. Two continuous maps $\varphi_0, \varphi_1 : X \rightarrow Y$ are *homotopic* if and only if there exists a continuous map $\varphi : X \times I \rightarrow Y$ such that, for $x \in X$,

$$\varphi(x, 0) = \varphi_0(x),$$

$$\varphi(x, 1) = \varphi_1(x).$$

If two maps φ_0 and φ_1 are homotopic, we shall denote this by $\varphi_0 \simeq \varphi_1$. We leave it to the reader to verify that this is an equivalence relation on the set of all continuous maps $X \rightarrow Y$. The equivalence classes are called *homotopy classes* of maps.

To better visualize the geometric content of the definition, let us write $\varphi_t(x) = \varphi(x, t)$ for any $(x, t) \in X \times I$. Then, for any $t \in I$,

$$\varphi_t : X \rightarrow Y$$

is a continuous map. Think of the parameter t as representing time. Then, at time $t = 0$, we have the map φ_0 , and, as t varies, the map φ_t varies *continuously* so that at time $t = 1$ we have the map φ_1 . For this reason, a homotopy is often spoken of as a continuous deformation of a map.¹

¹ The student who is familiar with the compact-open topology for function spaces will recognize that two maps $\varphi_0, \varphi_1 : X \rightarrow Y$ are homotopic if and only if they can be joined by an arc in the space of all continuous functions $X \rightarrow Y$ (provided X and Y satisfy certain hypotheses). Indeed, the map $t \rightarrow \varphi_t$ in the above notation is a path from φ_0 to φ_1 .

Definition. Two maps $\varphi_0, \varphi_1 : X \rightarrow Y$ are *homotopic relative to the subset A of X* if and only if there exists a continuous map $\varphi : X \times I \rightarrow Y$ such that

$$\begin{aligned}\varphi(x, 0) &= \varphi_0(x), & x \in X, \\ \varphi(x, 1) &= \varphi_1(x), & x \in X, \\ \varphi(a, t) &= \varphi_0(a) = \varphi_1(a), & a \in A, t \in I.\end{aligned}$$

Note that this condition implies $\varphi_0|_A = \varphi_1|_A$.

Theorem 4.1. Let $\varphi_0, \varphi_1 : X \rightarrow Y$ be maps that are homotopic relative to the subset $\{x\}$. Then

$$\varphi_{0*} = \varphi_{1*} : \pi(X, x) \rightarrow \pi(Y, \varphi_0(x)),$$

i.e., the induced homomorphisms are the same.

PROOF. The proof is immediate.

Unfortunately, the condition that the homotopy should be relative to the base point x is too restrictive for many purposes. This condition can be omitted, but we then complicate the statement of the theorem. We shall, however, do this in §8.

We shall now apply some of these results.

Definition. A subset A of a topological space X is called a *retract* of X if there exists a continuous map $r : X \rightarrow A$ (called a *retraction*) such that $r(a) = a$ for any $a \in A$.

As we shall see shortly, it is a rather strong condition to require that a subset A be a retract of X . A simple example of a retract of a space is the “center circle” of a Möbius strip. (What is the retraction in this case?)

Now let $r : X \rightarrow A$ be a retraction, as in the above definition, and $i : A \rightarrow X$ the inclusion map. For any point $a \in A$, consider the induced homomorphisms

$$\begin{aligned}i_* &: \pi(A, a) \rightarrow \pi(X, a), \\ r_* &: \pi(X, a) \rightarrow \pi(A, a).\end{aligned}$$

Because $ri = \text{identity map}$, we conclude that $r_*i_* = \text{identity homomorphism}$ of the group $\pi(A, a)$, by properties (d) and (e) given previously. From this we conclude that i_* is a *monomorphism* and r_* is an *epimorphism*. Moreover, the condition that $r_*i_* = \text{identity}$ imposes strong restrictions on the subgroup $i_*\pi(A, a)$ of $\pi(X, a)$.

We shall actually use this result later to prove that certain subspaces are not retracts.

EXERCISES

4.2. Show that a retract of a Hausdorff space must be a closed subset.

- 4.3. Prove that if A is a retract of X , $r : X \rightarrow A$ is a retraction, $i : A \rightarrow X$ is the inclusion, and $i_*\pi(A)$ is a normal subgroup of $\pi(X)$, then $\pi(X)$ is the direct product of the subgroups image i_* and kernel r_* (see §2 of Chapter III for the definition of direct product of groups).
- 4.4. Let A be a subspace of X , and let Y be a nonempty topological space. Prove that $A \times Y$ is a retract of $X \times Y$ if and only if A is a retract of X .
- 4.5. Prove that the relation "is a retract of" is transitive, i.e., if A is a retract of B and B is a retract of C , then A is a retract of C .

We now introduce the notion of *deformation retract*. The subspace A is a deformation retract of X if there exists a retraction $r : X \rightarrow A$ homotopic to the identity map $X \rightarrow X$. The precise definition is as follows:

Definition. A subset A of X is a *deformation retract*² of X if there exists a retraction $r : X \rightarrow A$ and a homotopy $f : X \times I \rightarrow X$ such that

$$\left. \begin{aligned} f(x, 0) &= x \\ f(x, 1) &= r(x) \end{aligned} \right\} x \in X,$$

$$f(a, t) = a, \quad a \in A, t \in I.$$

Theorem 4.2. *If A is a deformation retract of X , then the inclusion map $i : A \rightarrow X$ induces an isomorphism of $\pi(A, a)$ onto $\pi(X, a)$ for any $a \in A$.*

PROOF. As above, r_*i_* is the identity map of $\pi(A, a)$. We will complete the proof by showing that i_*r_* is the identity map of $\pi(X, a)$. This follows because ir is homotopic to the identity map $X \rightarrow X$ (relative to $\{a\}$); hence, Theorem 4.1 is applicable. Q.E.D.

We shall use this theorem in two different ways. On the one hand, we shall use it throughout the rest of this book to prove that two spaces have isomorphic fundamental groups. On the other hand, we can use it to prove that a subspace is not a deformation retract by proving the fundamental groups are not isomorphic. In particular, we shall be able to prove that certain retracts are not deformation retracts.

Definition. A topological space X is *contractible to a point* if there exists a point $x_0 \in X$ such that $\{x_0\}$ is a deformation retract of X .

Definition. A topological space X is *simply connected* if it is arcwise connected and $\pi(X, x) = \{1\}$ for some (and hence any) $x \in X$.

Corollary 4.3. *If X is contractible to a point, then X is simply connected.*

² Some authors define this term in a slightly weaker fashion.

Examples

4.1. A subset X of the plane or, more generally, of Euclidean n -space \mathbf{R}^n is called *convex* if the line segment joining any two points of X lies entirely in X . We assert that *any convex subset X of \mathbf{R}^n is contractible to a point*. To prove this, choose an arbitrary point $x_0 \in X$, and then define $f: X \times I \rightarrow X$ by the formula

$$f(x, t) = (1 - t)x + tx_0$$

for any $(x, t) \in X \times I$ [i.e., $f(x, t)$ is the point on the line segment joining x and x_0 which divides it in the ratio $(1 - t) : t$]. Then f is continuous, $f(x, 0) = x$, and $f(x, 1) = x_0$, as required. More generally, we may define a subset X of \mathbf{R}^n to be *starlike with respect to the point $x_0 \in X$* provided the line segment joining x and x_0 lies entirely in X for any $x \in X$. Then, the same proof suffices to show that if X is starlike with respect to x_0 , it is contractible to the point x_0 .

4.2. We assert that the unit $(n - 1)$ -sphere S^{n-1} is a deformation retract of $E^n - \{0\}$, the closed unit n -dimensional disc minus the origin. To prove this, define a map $f: X \times I \rightarrow X$, where

$$X = E^n - \{0\} = \{x \in \mathbf{R}^n : 0 < |x| \leq 1\},$$

by the formula

$$f(x, t) = (1 - t)x + t \cdot \frac{x}{|x|}.$$

(The reader should draw a picture to show what happens here when $n = 2$ or $n = 3$.) Then f is continuous, $f(x, 0) = x$, $f(x, 1) = x/|x| \in S^{n-1}$, and, if $x \in S^{n-1}$, then $f(x, t) = x$ for all $t \in I$. In particular, for $n = 2$, we see that the boundary circle is a deformation retract of a punctured disc.

EXERCISES

- 4.6. Let x_0 be any point in the plane \mathbf{R}^2 . Find a circle C in \mathbf{R}^2 which is a deformation retract of $\mathbf{R}^2 - \{x_0\}$. What is the n -dimensional analog of this fact?
- 4.7. Find a circle C which is a deformation retract of the Möbius strip.
- 4.8. Let T be a torus and let X be the complement of a point in T . Find a subset of X which is homeomorphic to a figure "8" curve (i.e., the union of two circles with a single point in common) and which is a deformation retract of X .
- 4.9. Generalize Exercise 4.8 to arbitrary compact surfaces, i.e., let S be a compact surface and let X be the complement of a point in S . Find a subset A of X such that (a) A is homeomorphic to the union of a finite number of circles and (b) A is a deformation retract of X . (HINT: Consider the representation of S as the space obtained by identifying in pairs the edges of a certain polygon.)
- 4.10. Let x and y be distinct points of a simply connected space X . Prove that there is a *unique* path class in X with initial point x and terminal point y .

4.11. Let X be a topological space, and for each positive integer n let X_n be an arcwise-connected subspace containing the base point $x_0 \in X$. Assume that the subspaces X_n are nested, i.e., $X_n \subset X_{n+1}$ for all n , that

$$X = \bigcup_{n=1}^{\infty} X_n,$$

and that for any compact subset A of X there exists an integer n such that $A \subset X_n$. (EXAMPLE: Each X_n is open.) Let $i_n : \pi(X_n) \rightarrow \pi(X)$ and $j_{mn} : \pi(X_m) \rightarrow \pi(X_n)$, $m < n$, denote homomorphisms induced by inclusion maps. Prove the following two statements: (a) For any $\alpha \in \pi(X)$, there exists an integer n and an element $\alpha' \in \pi(X_n)$ such that $i_n(\alpha') = \alpha$. (b) If $\beta \in \pi(X_m)$ and $i_m(\beta) = 1$, then there exists an integer $n \geq m$ such that $j_{mn}(\beta) = 1$. [REMARK: These two statements imply that $\pi(X)$ is the *direct limit* of the sequence of groups $\pi(X_n)$ and homomorphisms j_{mn} . We shall see examples later on where the hypotheses of this exercise are valid.] If the homomorphisms $j_{n,n+1}$ are monomorphisms for all n , prove that each i_n is also a monomorphism and that $\pi(X)$ is the union of the subgroups $i_n\pi(X_n)$.

§5. The Fundamental Group of a Circle is Infinite Cyclic

Let S^1 denote the unit circle in the Euclidean plane \mathbf{R}^2 , $S^1 = \{(x, y) \in \mathbf{R}^2 : x^2 + y^2 = 1\}$ (or, equivalently, in the complex plane \mathbf{C}). Let $f : I \rightarrow S^1$ denote the closed path that goes around the circle exactly once, defined by

$$f(t) = (\cos 2\pi t, \sin 2\pi t), \quad 0 \leq t \leq 1,$$

and denote the equivalence class of f by the symbol α .

Theorem 5.1. *The fundamental group $\pi(S^1, (1, 0))$ is an infinite cyclic group generated by the path class α .*

PROOF. Let $g : I \rightarrow S^1$, $g(0) = g(1) = (1, 0)$ be a closed path in S^1 . We shall prove first that g belongs to the equivalence class α^m for some integer m (m may be positive, negative, or zero). Let

$$U_1 = \{(x, y) \in S^1 : y > -\frac{1}{10}\},$$

$$U_2 = \{(x, y) \in S^1 : y < +\frac{1}{10}\}.$$

Then, U_1 and U_2 are connected open subsets of S^1 , each of which is slightly larger than a semicircle, and $U_1 \cup U_2 = S^1$. Obviously U_1 and U_2 are each homeomorphic to an open interval of the real line, hence, each is contractible. In the case where $g(I) \subset U_1$ or $g(I) \subset U_2$, it is then clear that g is equivalent to the constant path, and hence belongs to the equivalence class of α^0 . We put this case aside and assume from now on that $g(I) \not\subset U_1$ and $g(I) \not\subset U_2$.

We next assert that it is possible to divide the unit interval into subintervals $[0, t_1], [t_1, t_2], \dots, [t_{n-1}, 1]$, where $0 = t_0 < t_1 < \dots < t_{n-1} < t_n = 1$, such

that the following conditions hold:

- (a) $g([t_i, t_{i+1}]) \subset U_1$ or
 $g([t_i, t_{i+1}]) \subset U_2$ for $0 \leq i < n$.
- (b) $g([t_{i-1}, t_i])$ and $g([t_i, t_{i+1}])$

are not both contained in the *same* open set $U_j, j = 1$ or 2 .

This assertion may be proved as follows. $\{g^{-1}(U_1), g^{-1}(U_2)\}$ is an open covering of the compact metric space I ; let ε be a Lebesgue number³ of this covering.

Divide the unit interval in any way whatsoever into subintervals of length $< \varepsilon$. With this subdivision, condition (a) will hold; however, condition (b) may not hold. If two consecutive subintervals are mapped by g into the same set U_j , then amalgamate these two subintervals into a single subinterval by omitting the common end point. Continue this process of amalgamation until condition (b) holds.

Let β denote the equivalence class of the path g , and let β_i denote the equivalence class of $g|_{[t_{i-1}, t_i]}$ for $1 \leq i \leq n$. Then, obviously, β is a product,

$$\beta = \beta_1 \cdot \beta_2 \cdot \dots \cdot \beta_n.$$

Each β_i is a path in U_1 or U_2 . Because of condition (b), it is clear that $g(t_i) \in U_1 \cap U_2$. $U_1 \cap U_2$ has two components, one of which contains the point $(1, 0)$, and the other of which contains the point $(-1, 0)$. For each index i , $0 < i < n$, choose a path class γ_i in $U_1 \cap U_2$ with initial point $g(t_i)$ and terminal point $(1, 0)$ or $(-1, 0)$, depending on which component of $U_1 \cap U_2$ contains $g(t_i)$. Let

$$\begin{aligned} \delta_1 &= \beta_1 \gamma_1, \\ \delta_i &= \gamma_{i-1}^{-1} \beta_i \gamma_i \quad \text{for } 1 < i < n, \\ \delta_n &= \gamma_{n-1}^{-1} \beta_n. \end{aligned}$$

Then, it is clear that

$$\beta = \delta_1 \delta_2 \cdots \delta_n. \tag{2.51}$$

where each δ_i is a path class in U_1 or U_2 having its initial and terminal points in the set $\{(1, 0), (-1, 0)\}$. For any index i , if δ_i is a closed path class, then $\delta_i = 1$, because U_1 and U_2 are simply connected. We may therefore assume that any such δ_i has been dropped from formula (2.5-1), and, changing notation if necessary, that $\delta_1, \delta_2, \dots$, and δ_n are not closed paths.

Because U_1 is simply connected, there is a unique path class η_1 in U_1 with

³ We say ε is a *Lebesgue number* of a covering of a metric space X if the following condition holds: Any subset of X of diameter $< \varepsilon$ is contained in some set of the covering. It is a theorem that any open covering of a compact metric space has a Lebesgue number. The reader may either prove this as an exercise or look up the proof in a textbook on general topology.

initial point $(1, 0)$ and terminal point $(-1, 0)$ (see Exercise 4.10). Also, η_1^{-1} is the unique path class in U_1 with initial point $(-1, 0)$ and terminal point $(1, 0)$. Analogously, we denote by η_2 the unique path class in U_2 with initial point $(-1, 0)$ and terminal point $(1, 0)$. Note that $\eta_1\eta_2 = \alpha$.

Thus, we see that, for each index i ,

$$\delta_i = \eta_1^{\pm 1} \quad \text{or} \quad \delta_i = \eta_2^{\pm 1}.$$

In view of condition (b) above, if $\delta_i = \eta_1^{\pm 1}$, then $\delta_{i+1} = \eta_2^{\pm 1}$, while if $\delta_i = \eta_2^{\pm 1}$, then $\delta_{i+1} = \eta_1^{\pm 1}$. Therefore only the following possibilities remain:

$$\beta = 1,$$

$$\beta = \eta_1\eta_2\eta_1\eta_2 \cdots \eta_1\eta_2,$$

or

$$\beta = \eta_2^{-1}\eta_1^{-1}\eta_2^{-1}\eta_1^{-1} \cdots \eta_2^{-1}\eta_1^{-1}.$$

In the second case $\beta = \alpha^m$ for some $m > 0$, whereas in the third case $\beta = \alpha^m$ for some integer $m < 0$. Thus, we have $\beta = \alpha^m$ in all cases.

From this it follows that $\pi(S^1)$ is a cyclic group. However, this argument gives no hint as to the order of $\pi(S^1)$. In §3 of Chapter V we will complete the proof by showing that $\pi(S^1)$ is an infinite group, using the theory of covering spaces; another proof is given in the discussion of Example 7.1 of Chapter V. When we introduce homology theory later on, it will be easy to give still other proofs.

It would be possible to give a direct, ad hoc proof now that $\pi(S^1)$ is infinite; see Massey ([2], Chapter II) or Ahlfors and Sario ([1], Chapter I, Section 10). It is also possible to give a proof using the concept of the *winding number* or *index* of a closed path in the plane with respect to a point; this is explained in most textbooks on complex function theory. The theory of the winding number or index can also be developed in the context of real function theory.

Given the fundamental importance of Theorem 5.1 and its basic intuitive appeal, it is not surprising that there should be so many different proofs available. Q.E.D.

As a corollary of Theorem 5.1, we see that the fundamental group of any space with a circle as deformation retract is infinite cyclic. Examples of such spaces are the Möbius strip, a punctured disc, the punctured plane, a region in the plane bounded by two concentric circles, etc. (see the exercises in the preceding section).

EXERCISES

- 5.1. Let $\{U_i\}$ be an open covering of the space X having the following properties:
 (a) There exists a point x_0 such that $x_0 \in U_i$ for all i . (b) Each U_i is simply connected.

(c) If $i \neq j$, then $U_i \cap U_j$ is arcwise connected. Prove that X is simply connected. [HINT: To prove any loop $f: I \rightarrow X$ based at x_0 is trivial, first consider the open covering $\{f^{-1}(U_i)\}$ of the compact metric space I and make use of the Lebesgue number of this covering.]

Remark. The two most important cases of this exercise are the following: (1) A covering by two open sets and (2) the sets U_i are linearly ordered by inclusion. The student should restate the exercise for these two special cases.

- 5.2. Use the result of Exercise 5.2, remark (1), to prove that the unit 2-sphere S^2 or, more generally, the n -sphere S^n , $n \geq 2$, is simply connected.
- 5.3. Prove that \mathbf{R}^2 and \mathbf{R}^n are not homeomorphic if $n \neq 2$. (HINT: Consider the complement of a point in \mathbf{R}^2 or \mathbf{R}^n .)
- 5.4. Prove that any homeomorphism of the closed disc E^2 onto itself maps S^1 onto S^1 and U^2 onto U^2 .

§6. Application: The Brouwer Fixed-Point Theorem in Dimension 2

One of the best known theorems of topology is the following fixed-point theorem of L.E.J. Brouwer. Let E^n denote the closed unit ball in Euclidean n -space \mathbf{R}^n :

$$E^n = \{x \in \mathbf{R}^n : |x| \leq 1\}.$$

Theorem 6.1. *Any continuous map f of E^n into itself has at least one fixed point, i.e., a point x such that $f(x) = x$.*

We shall only prove this theorem for $n \leq 2$. Before going into the proof, it seems worthwhile to indicate why there should be interest in fixed-point theorems such as this one.

Suppose we have a system of n equations in n unknowns:

$$\begin{aligned} g_1(x_1, \dots, x_n) &= 0, \\ g_2(x_1, \dots, x_n) &= 0, \\ &\vdots \\ g_n(x_1, \dots, x_n) &= 0. \end{aligned} \tag{2.6.1}$$

Here the g_i 's are assumed to be continuous real-valued functions of the real variables x_1, \dots, x_n . It is often an important problem to be able to decide whether or not such a system of equations has a solution. We can transform this problem into a fixed-point problem as follows. Let

$$h_i(x_1, \dots, x_n) = g_i(x_1, \dots, x_n) + x_i$$

for $i = 1, 2, \dots, n$. Then, for any point $x = (x_1, \dots, x_n)$, we define

$$h(x) = (h_1(x), \dots, h_n(x)).$$

Then, h is a continuous function mapping a certain subset of Euclidean n -space (depending on the domain of definition of the functions g_1, \dots, g_n) into Euclidean n -space. If we can find a subset X of Euclidean n -space homeomorphic to E^n , such that h is defined in X and $h(X) \subset X$, then we can conclude by Brouwer's theorem that the function h has a fixed point in the set X ; but any fixed point of the function h is readily seen to be a common solution of Equations (2.6.1).

Brouwer's theorem has been extended from the subset E^n of Euclidean space to apply to certain subsets of function spaces. The resulting theorem can then be used to prove existence theorems for ordinary and partial differential equations; in fact, this is one of the most powerful methods of proving existence theorems for certain types of nonlinear equations.

PROOF OF THEOREM 6.1. For $n \leq 2$: First we prove that, for any integer $n > 0$, the existence of a continuous map $f: E^n \rightarrow E^n$, which has no fixed points, implies that the $(n - 1)$ -sphere $S^{n-1} = \{x \in \mathbf{R}^n : |x| = 1\}$ is a retract of E^n . We do this by the following simple geometric construction. For any point $x \in E^n$, let $r(x)$ denote the point of intersection of S^{n-1} and the ray starting at the point $f(x)$ and going through the point x . Figure 2.4 shows the situation for the case where $n = 2$. Using vector notation, we can easily write a formula for $r(x)$ in terms of $f(x)$. From this formula, we see that r is a continuous map of E^n into S^{n-1} . If $x \in S^{n-1}$, it is clear that $r(x) = x$. Therefore, r is the desired retraction.

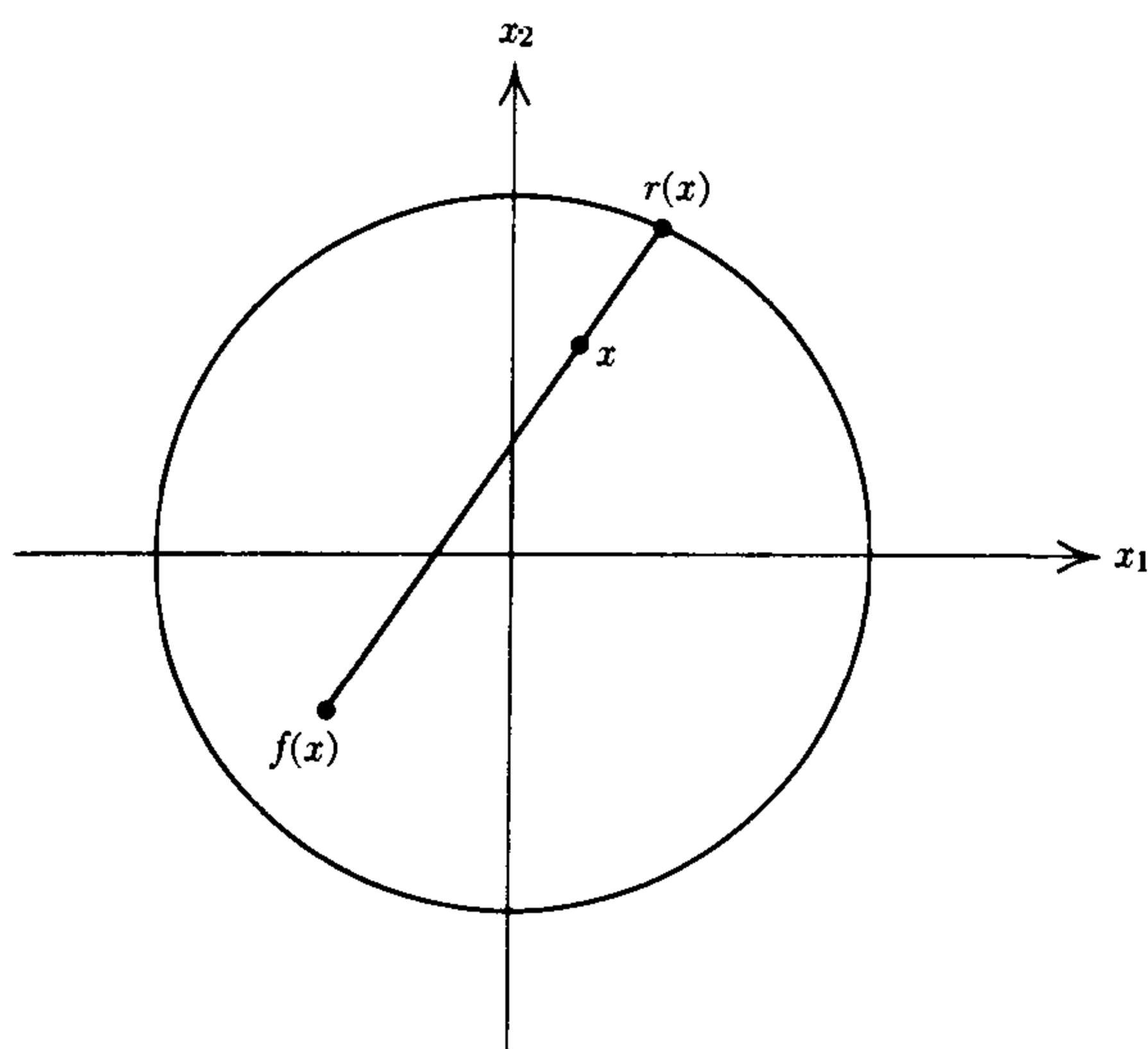

FIGURE 2.4. Proof of the Brouwer Fixed-Point Theorem.

If we could prove that S^{n-1} is not a retract of E^n , then we would have a contradiction. For $n = 1$, this is clear, because E^1 is connected, but S^0 is disconnected. For $n = 2$, we invoke what we have learned about the fundamental groups of retracts. Because $\pi(S^1)$ is infinite cyclic, whereas $\pi(E^2)$ is a trivial group, it easily follows that S^1 is not a retract of E^2 (see the discussion of retracts in §4). Q.E.D.

The proof of this theorem for the case where $n > 2$ will be given in Chapter VIII.

§7. The Fundamental Group of a Product Space

In this section, we shall prove that the fundamental group of the product of two spaces is naturally isomorphic to the direct product of their fundamental groups; in symbols,

$$\pi(X \times Y) \approx \pi(X) \times \pi(Y).$$

(For a review of the definition of the direct product of groups, see §2 of Chapter III.)

Let X , Y , and A be topological spaces. If $f: A \rightarrow X \times Y$ is any map, let us denote the coordinates of $f(a)$ by $(f_1(a), f_2(a))$ for any point $a \in A$. Then f_1 and f_2 are maps of A into X and Y , respectively, and it is well known f is continuous if and only if both f_1 and f_2 are continuous. This is a basic property of the product topology. Thus, a natural one-to-one correspondence exists between continuous maps $f: A \rightarrow X \times Y$ and pairs of continuous maps $f_1: A \rightarrow X$, $f_2: A \rightarrow Y$. If we denote by $p: X \times Y \rightarrow X$ and $q: X \times Y \rightarrow Y$ the projection of the product space onto its two factors, then $f_1 = pf$ and $f_2 = qf$.

Let us apply these considerations to the case where $A = I$, the unit interval. We see that there is a natural one-to-one correspondence between paths $f: I \rightarrow X \times Y$ in the product space and pairs of paths $f_1: I \rightarrow X$, $f_2: I \rightarrow Y$ in the factors. Note that $f_1 = pf$ and $f_2 = qf$ as before. This natural correspondence has the following obvious but important properties:

- (a) If $f, g: I \rightarrow X \times Y$ are paths with the same initial and terminal points, then $f \sim g$ if and only if $f_1 \sim g_1$ and $f_2 \sim g_2$ (here $g_1 = pg$ and $g_2 = qg$).
- (b) Let $f, g: I \rightarrow X \times Y$ be paths such that the terminal point of f is the initial point of g , and let $h = f \cdot g$. Then $h_1 = f_1 \cdot g_1$ and $h_2 = f_2 \cdot g_2$, where $h_1 = ph$ and $h_2 = qh$.

We can summarize these two statements by stating that the natural correspondence $f \leftrightarrow (f_1, f_2)$ is compatible with the equivalence relation and product we have defined between paths. We leave the verification of these statements to the reader.

Now let us apply these considerations to the study of the fundamental group of the product space, $\pi(X \times Y, (x, y))$. Let $p_* : \pi(X \times Y, (x, y)) \rightarrow \pi(X, x)$ and $q_* : \pi(X \times Y, (x, y)) \rightarrow \pi(Y, y)$ denote the homomorphisms induced by the projections p and q . From property (a), we see that the correspondence $\alpha \rightarrow (p_*\alpha, q_*\alpha)$ establishes a one-to-one correspondence between the sets $\pi(X \times Y, (x, y))$ and $\pi(X, x) \times \pi(Y, y)$. Moreover, it follows from property (b) that this correspondence preserves products, i.e., it is an isomorphism of groups. We summarize these results as follows:

Theorem 7.1. *The fundamental group of the product space, $\pi(X \times Y, (x, y))$, is naturally isomorphic to the direct product of fundamental groups, $\pi(X, x) \times \pi(Y, y)$. The isomorphism is defined by assigning to any element $\alpha \in \pi(X \times Y, (x, y))$ the ordered pair $(p_*\alpha, q_*\alpha)$, where $p : X \times Y \rightarrow X$ and $q : X \times Y \rightarrow Y$ denote the projections of the product space onto its factors.*

Obviously, this theorem can be extended to the product of any finite number of spaces.

EXERCISES

- 7.1. Describe the structure of the fundamental group of a torus.
- 7.2. Prove that the subset $S^1 \times \{x_0\}$ is a retract of $S^1 \times S^1$, but that it is not a deformation retract of $S^1 \times S^1$ for any point $x_0 \in S^1$.
- 7.3. Generalize Theorem 7.1 to obtain a description of the fundamental group of the product of an infinite collection of topological spaces.
- 7.4. Let $i : X \rightarrow X \times Y$ and $j : Y \rightarrow X \times Y$ be maps defined by $i(x) = (x, y_0)$ and $j(y) = (x_0, y)$, where $x_0 \in X$ and $y_0 \in Y$ are base points which are chosen once for all. Prove that the mapping of $\pi(X, x_0) \times \pi(Y, y_0)$ into $\pi(X \times Y, (x_0, y_0))$ defined by $(\beta, \gamma) \rightarrow (i_*\beta) \cdot (j_*\gamma)$ is an isomorphism of the first group onto the second. (HINT: Prove it is the inverse of the isomorphism described in Theorem 7.1.) Deduce as a corollary that the elements $i_*\beta$ and $j_*\gamma$ commute, i.e., $(i_*\beta)(j_*\gamma) = (j_*\gamma)(i_*\beta)$.
- 7.5. Assume that G is a topological space, $\mu : G \times G \rightarrow G$ is a continuous map, and $e \in G$ is such that the following conditions hold: For any $x \in G$, $\mu(x, e) = \mu(e, x) = x$. [An important example: G is a topological group, e is the identity element, and $\mu(x, y) =$ the product of x and y for any elements $x, y \in G$.] Let $i : G \rightarrow G \times G$ and $j : G \rightarrow G \times G$ be defined as in Exercise 7.4: $i(x) = (x, e)$ and $j(x) = (e, x)$ for any $x \in G$. Prove that, for any elements $\beta, \gamma \in \pi(G, e)$, $\mu_*[(i_*\beta)(j_*\gamma)] = \beta \cdot \gamma$. [HINT: Consider first the case where β or $\gamma = 1$.] Deduce as a corollary that $\pi(G, e)$ is an abelian group.
- 7.6. Let $G, e,$ and μ be as in Exercise 7.5. Assume in addition that there exists a continuous map $c : G \rightarrow G$ such that $\mu(x, c(x)) = \mu(c(x), x) = e$ for any $x \in G$. [An important example: G is a topological group and $c(x) = x^{-1}$ for any $x \in G$.] Prove that, for any element $\beta \in \pi(G, e)$, $e_*(\beta) = \beta^{-1}$.

§8. Homotopy Type and Homotopy Equivalence of Spaces

Before we can prove the next theorem, we need to develop some preliminary material about the topology of certain subsets of the plane. A topological space will be called a *closed disc* if it is homeomorphic to the set

$$E^2 = \{(x, y) \in \mathbf{R}^2 : x^2 + y^2 \leq 1\};$$

it will be called an *open disc* if it is homeomorphic to the set

$$U^2 = \{(x, y) \in \mathbf{R}^2 : x^2 + y^2 < 1\}.$$

The *boundary* of a closed disc is the subset that corresponds to the circle S^1 under a homeomorphism of the disc onto E^2 ; it can be proved that this subset is independent of the choice of the homeomorphism (see Exercise 5.5).

We shall now consider some elementary properties of discs.

- (a) Any compact, convex subset E of the plane with nonempty interior is a closed disc.

PROOF. We can set up a homeomorphism between E and E^2 as follows. Choose a point x_0 belonging to the interior of E . Consider any ray in the plane starting at the point x_0 ; the intersection of this ray with E must be a closed interval having x_0 as one end point. Map this interval linearly onto the unit interval on the parallel ray through the origin. If we do this for each ray through x_0 , we obtain a one-to-one correspondence between the points of E and E^2 which can be proved to be continuous in both directions.

- (b) Let E_1 and E_2 be closed discs with boundaries B_1 and B_2 , respectively. Then, any continuous map $f : B_1 \rightarrow B_2$ can be extended to a continuous map $F : E_1 \rightarrow E_2$. If f is a homeomorphism, then we can choose F to be a homeomorphism also.

PROOF. In view of the definition of a closed disc, it suffices to prove this statement in the case where $E_1 = E_2 = E^2$ and $B_1 = B_2 = S^1$. We leave this proof to the reader.

- (c) Let E_1 be a closed disc. Let E_2 denote the quotient space of E_1 obtained by identifying a closed segment of the boundary of E_1 to a point. Then, this quotient space E_2 is again a closed disc.

PROOF. In view of property (b), it suffices to prove this assertion for the case of a particular closed disc and a particular segment on the boundary of that disc. We are at liberty to choose the particular disc and segment in any convenient way. We choose E_1 to be the trapezoid $ABDE$ in the xy plane shown in Figure 2.5, and E_2 to be the triangle ABC . We shall define a map $f : E_1 \rightarrow E_2$ such that the segment DE of the boundary of E_1 is mapped onto the vertex C of E_2 , but otherwise f is one-to-one. Then, we shall complete the proof by showing that E_2 has the quotient topology determined by f .

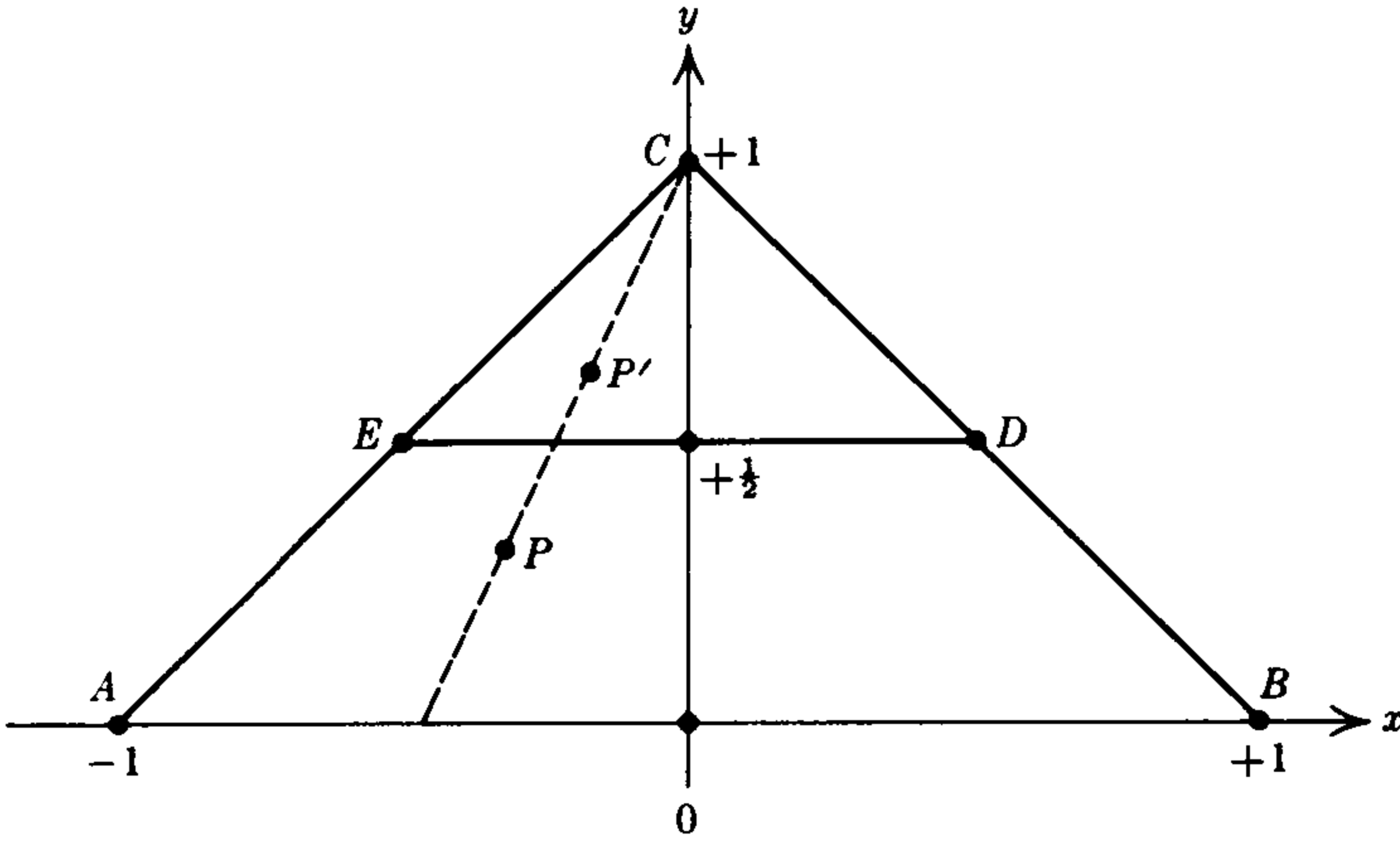

FIGURE 2.5. Proof of Theorem 8.3.

We define f by the condition that, for any point $P \in E_1$, the points P , $P' = f(P)$ and $C = (0, 1)$ will lie on a straight line, and the y coordinate of P' will be twice that of P . If (x, y) are the coordinates of P and (x', y') are the coordinates of P' , then we find that

$$\left. \begin{aligned} x' &= x \left(\frac{2y - 1}{y - 1} \right) \\ y' &= 2y \end{aligned} \right\} 0 \leq y \leq \frac{1}{2}$$

or

$$\left. \begin{aligned} x &= x' \left(\frac{y' - 2}{2y' - 2} \right) \\ y &= \frac{1}{2}y' \end{aligned} \right\} 0 \leq y' < 1.$$

This first pair of formulas shows that f is continuous, whereas the second pair of formulas shows that f is one-to-one except on the segment DE ; obviously the segment DE is all mapped into the point C . Because E_1 is compact and E_2 is Hausdorff, f is a closed map, and hence E_2 has the quotient topology.

Q.E.D.

We are now ready to state and prove a key lemma. Let D denote a closed disc, let B denote its boundary (which is a circle), and let $g : I \rightarrow B$ denote a continuous map which wraps the interval exactly once around the circle; i.e., $g(0) = g(1) = d_0 \in B$, and g maps the open interval $(0, 1)$ homeomorphically onto $B - \{d_0\}$. Let X be a topological space.

Lemma 8.1. *A continuous map $f : B \rightarrow X$ can be extended to a map $D \rightarrow X$ if and only if the closed loop $fg : I \rightarrow X$ is equivalent to the constant loop at the base point $f(d_0)$.*

PROOF. First assume that $f: B \rightarrow X$ can be extended to a continuous map $F: D \rightarrow X$. Consider the unit square $\{(x, y) \in \mathbf{R}^2 : 0 \leq x \leq 1 \text{ and } 0 \leq y \leq 1\}$. Define a continuous map h of the boundary of this square into B as follows:

$$\begin{aligned} h(x, 0) &= g(x), & 0 \leq x \leq 1, \\ h(x, 1) &= h(0, y) = h(1, y) = d_0 \end{aligned} \tag{2.8.1}$$

for $x \in I$ or $y \in I$. By property (b), we can extend h to a continuous map H of the unit square. Then, the existence of the composite map FH proves the loop fg is equivalent to the constant path.

Next, assume the loop fg is equivalent to the constant path. By definition, this means there exists a continuous map G of the unit square into X such that

$$\begin{aligned} G(x, 0) &= f(g(x)), \\ G(x, 1) &= G(0, y) = G(1, y) = f(d_0). \end{aligned}$$

Because G maps the top and the two sides of this square into the single point $f(d_0)$, it is clear that G induces a continuous map of the quotient space of the square (obtained by identifying the top and two sides of the square to a single point) into X . By property (c), this quotient space is a closed disc, which we may take to be D , and the natural map of the boundary of the square onto the quotient space may be taken to be the map h in Equations (2.8.1). The induced map of the disc D into X is clearly an extension of f , as desired. Q.E.D.

In applying this lemma, it is convenient to use the following “abuse of language”: We shall say that the map $f: B \rightarrow X$ “represents” the equivalence class of the loop fg .

To state the next theorem, let $\varphi_0, \varphi_1: X \rightarrow Y$ be continuous maps, and let $\varphi: X \times I \rightarrow Y$ be a homotopy between φ_0 and φ_1 , i.e., $\varphi(x, 0) = \varphi_0(x)$ and $\varphi(x, 1) = \varphi_1(x)$. Choose a base point $x_0 \in X$. Then, φ_0 and φ_1 induce homomorphisms

$$\begin{aligned} \varphi_{0*} &: \pi(X, x_0) \rightarrow \pi(Y, \varphi_0(x_0)), \\ \varphi_{1*} &: \pi(X, x_0) \rightarrow \pi(Y, \varphi_1(x_0)). \end{aligned}$$

Let γ denote the homotopy class of the path $t \rightarrow \varphi(x_0, t)$, $0 \leq t \leq 1$, in Y . This defines an isomorphism $u: \pi(Y, \varphi_0(x_0)) \rightarrow \pi(Y, \varphi_1(x_0))$ by the formula

$$u(\alpha) = \gamma^{-1}\alpha\gamma, \quad \alpha \in \pi(Y, \varphi_0(x_0)).$$

Theorem 8.2. *Under the above hypotheses, the following diagram is commutative:*

$$\begin{array}{ccc} & & \pi(Y, \varphi_0(x_0)) \\ & \nearrow \varphi_{0*} & \downarrow u \\ \pi(X, x_0) & & \pi(Y, \varphi_1(x_0)) \\ & \searrow \varphi_{1*} & \end{array}$$

This theorem is the natural and full generalization of Theorem 4.1.

PROOF. Let $\alpha \in \pi(X, x_0)$; we must prove that

$$\varphi_{1*}(\alpha) = \gamma^{-1}(\varphi_{0*}\alpha)\gamma.$$

Choose a closed path $f: I \rightarrow X$ representing the path α . Consider the map

$$g: I \times I \rightarrow Y$$

defined by

$$g(x, y) = \varphi(f(x), y).$$

Then, for $x, y \in I$, we have

$$g(x, 0) = \varphi_0(f(x)),$$

$$g(x, 1) = \varphi_1(f(x)),$$

$$g(0, y) = g(1, y) = \varphi(x_0, y).$$

Hence, the map g of the bottom of the square represents $\varphi_{0*}(\alpha)$, on the top of the square it represents $\varphi_{1*}(\alpha)$, and on the two sides of the square it represents γ . If we read around the boundary of the square, the map represents $(\varphi_{0*}\alpha)\gamma(\varphi_{1*}\alpha)^{-1}\gamma^{-1}$. Now apply Lemma 8.1 conclude that

$$(\varphi_{0*}\alpha)\gamma(\varphi_{1*}\alpha)^{-1}\gamma^{-1} = 1.$$

From this the desired equation follows [multiply on the right by $\gamma(\varphi_{1*}\alpha)$ and then on the left by γ^{-1}]. Q.E.D.

Definition. Two spaces X and Y are of the same homotopy type if there exist continuous maps (called *homotopy equivalences*) $f: X \rightarrow Y, g: Y \rightarrow X$ such that $gf \simeq \text{identity}: X \rightarrow X$ and $fg \simeq \text{identity}: Y \rightarrow Y$.

Obviously, two homeomorphic spaces are of the same homotopy type, but the converse is not true.

EXERCISES

8.1. Prove that, if A is a deformation retract of X , then the inclusion $i: A \rightarrow X$ is a homotopy equivalences. (Actually, one of the conditions in the definition of a deformation retract given in §4 is superfluous here; omission of this condition leads to the notion of a “deformation retract in the weak sense.” For spaces which are sufficiently “nice,” it can be proved that the two notions agree.)

Theorem 8.3. If $f: X \rightarrow Y$ is a homotopy equivalence, then $f_*: \pi(X, x) \rightarrow \pi(Y, f(x))$ is an isomorphism for any $x \in X$.

PROOF. Because $gf \simeq \text{identity}: X \rightarrow X$, we obtain the following diagram (which is commutative by Theorem 8.2):

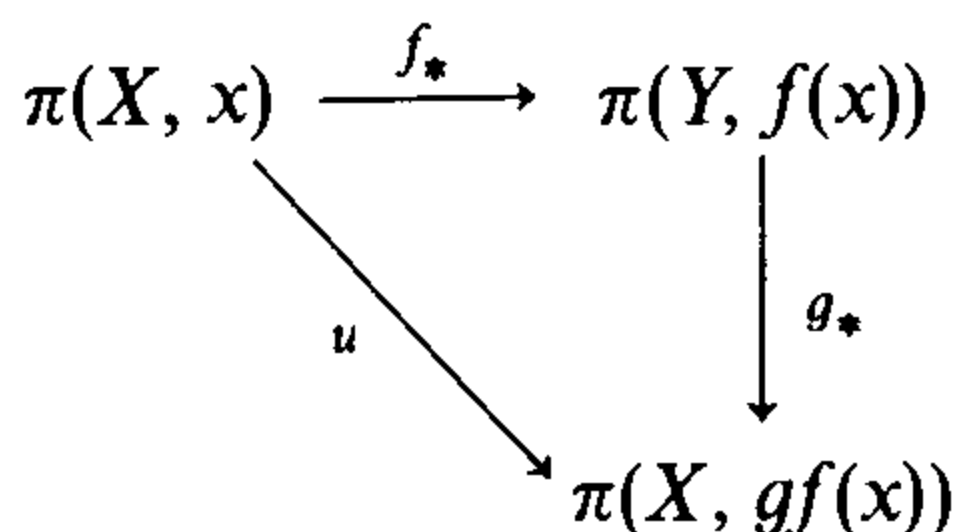

Here u is an isomorphism induced by a certain path from x to $gf(x)$. Therefore, we conclude f_* is a monomorphism and g_* is an epimorphism.

If we apply the same argument to the homotopy $fg \simeq \text{identity} : Y \rightarrow Y$, we obtain the following commutative diagram:

$$\begin{array}{ccc} \pi(Y, f(x)) & & \\ \downarrow g_* & \searrow u & \\ \pi(X, gf(x)) & \longrightarrow & \pi(Y, fgf(x)) \end{array}$$

Therefore, we conclude g_* is a monomorphism. Because g_* is both an epimorphism and a monomorphism, it is an isomorphism. Because

$$g_* f_* = u$$

and both g_* and u are isomorphisms, we conclude that f_* is also an isomorphism. Q.E.D.

This theorem will be used as an aid in the determination of the fundamental group of certain spaces, and as a method of proving that certain spaces are not of the same homotopy type (and hence are not homeomorphic).

EXERCISE

- 8.2.** Assume that G , μ , and e satisfy the hypotheses of Exercise 7.5. Use Lemma 8.1 to prove directly that for any elements $\alpha, \beta \in \pi(G, e)$, $\alpha\beta\alpha^{-1}\beta^{-1} = 1$. (HINT: Choose D to be a square, and choose a map of B into G which represents $\alpha\beta\alpha^{-1}\beta^{-1}$. Use the existence of μ to define the required extension.) Deduce that $\pi(G, e)$ is abelian.

NOTES

The fundamental group was introduced by the great French mathematician Henri Poincaré in 1895 (*Analysis Situs*, *J. Ecole Polytechn.* 1 (1895), 1–121). The notation of two spaces being of the same homotopy type was introduced by Witold Hurewicz in a series of four papers, in 1935–1936, which appeared in the *Proceedings of the Koninklijke Nederlandse Akademie van Wetenschappen*. In these papers, Hurewicz also introduced higher-dimensional analogs of the fundamental group, called *homotopy groups*. These ideas of Hurewicz have played a significant role in algebraic topology since 1935.

The reader who is interested in the proof of existence theorems in analysis by the use of fixed-point theorems is referred to the following book by Jane Cronin: *Mathematical Surveys No. 11, Fixed Points and Topological Degree in Nonlinear Analysis*, American Mathematical Society, Providence, R.I., 1964.

References

1. L. V. Ahlfors and L. Sario, *Riemann Surfaces*, Princeton University Press, Princeton, N.J., 1960.
2. W. S. Massey, *Algebraic Topology: An Introduction*, Springer-Verlag, New York, 1987.

CHAPTER III

Free Groups and Free Products of Groups

§1. Introduction

In the preceding chapters we have introduced the fundamental group of a space and actually determined its structure in some of the simplest cases. In more complicated cases we need a larger vocabulary and a greater knowledge of group theory to describe its structure and actually to make use of its properties. The object of this chapter is to supply this need. We first discuss the case of abelian groups because this case is simpler and more closely related to the student's previous experience. Then we discuss the general case of not necessarily abelian groups. Here the results are entirely analogous to the abelian case, but the possibilities are more varied and less intuitive.

The three main group theoretic concepts introduced in this chapter are the following: free group, free product of groups, and presentation of a group by generators and relations. These concepts will be used throughout the next two chapters. The definition of a free group or a free product of groups involves a mathematical concept of wide application, the so-called "universal mapping problem," which is also a basic concept in Chapter IV.

§2. The Weak Product of Abelian Groups

We assume the student is familiar with the concept of the *direct product* of a finite number of groups,

$$G = G_1 \times G_2 \times \cdots \times G_n.$$

The elements of G are ordered n -tuples

$$g = (g_1, g_2, \dots, g_n),$$

where $g_i \in G_i$ for $i = 1, 2, \dots, n$, with multiplication defined componentwise:

$$(g_1, g_2, \dots, g_n)(g'_1, g'_2, \dots, g'_n) = (g_1 g'_1, g_2 g'_2, \dots, g_n g'_n).$$

It is easy to extend this definition to the case of an infinite collection of groups $\{G_i : i \in I\}$. Here I is an index set, which may be countable or uncountable. The *direct product* of such a collection is denoted by

$$\prod_{i \in I} G_i.$$

Its elements are functions g which assign to each index $i \in I$ an element $g_i \in G_i$. These elements are multiplied componentwise: if g and h are elements of the direct product, then

$$(gh)_i = (g_i)(h_i)$$

for any $i \in I$.

Let $\{G_i : i \in I\}$ be any collection of groups, and let

$$G = \prod_{i \in I} G_i$$

be their product.

Definition. The *weak product*¹ of the collection $\{G_i : i \in I\}$ is the subgroup of their product G consisting of all elements $g \in G$ such that g_i is the identity element of G_i for all except a finite number of indices i .

Obviously, if $\{G_i : i \in I\}$ is a finite collection of groups, then the product and weak product are the same.

If G denotes either the product or weak product of the collection $\{G_i : i \in I\}$, then, for each index $i \in I$, there is a *natural monomorphism* $\varphi_i : G_i \rightarrow G$ defined by the following rule: For any element $x \in G_i$ and any index $j \in I$,

$$(\varphi_i x)_j = \begin{cases} x & \text{if } j = i \\ 1 & \text{if } j \neq i. \end{cases}$$

In the case where each G_i is an *abelian* group, the following theorem gives an important characterization of their weak product G and the monomorphisms φ_i .

Theorem 2.1. *If $\{G_i : i \in I\}$ is a collection of abelian groups and G is their weak product, then for any abelian group A and any collection of homomorphisms*

$$\psi_i : G_i \rightarrow A, \quad i \in I,$$

¹ When each group G_i is abelian and the group operation is addition, it is customary to call the weak product the "direct sum." In this definition, we do not require that any two groups in the collection $\{G_i\}$ be nonisomorphic. In fact, it may even occur that all of the groups of the collection are isomorphic to some given group.

there exists a unique homomorphism $f: G \rightarrow A$ such that for any $i \in I$ the following diagram is commutative:

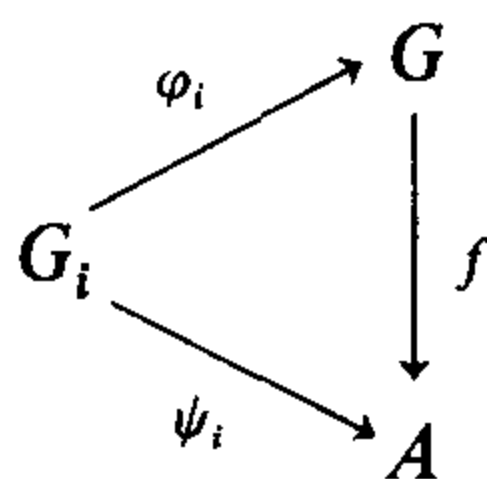

PROOF. Given the ψ_i 's, define f by the following rule: For any $x \in G$, $f(x)$ will be the product of the elements $\psi_i(x_i)$ for all $i \in I$. Because $x_i = 1$ for all except a finite number of indices i , this product is really a finite product; and because all the groups involved are abelian, the order of multiplication is immaterial. Thus, $f(x)$ is well defined, and it is readily verified that f is a homomorphism, which renders the given diagram commutative. It is easy to see that f is the unique homomorphism having this property. Q.E.D.

Our next proposition states that this theorem actually characterizes the weak product of abelian groups.

Proposition 2.2. *Let $\{G_i\}$, G , and $\varphi_i: G_i \rightarrow G$ be as in Theorem 2.1; let G' be any abelian group and let $\varphi'_i: G_i \rightarrow G'$ be any collection of homomorphisms such that the conclusion of Theorem 2.1 holds with G' and φ'_i substituted for G and φ_i , respectively. Then, there exists a unique isomorphism $h: G \rightarrow G'$ such that the following diagram is commutative for any $i \in I$:*

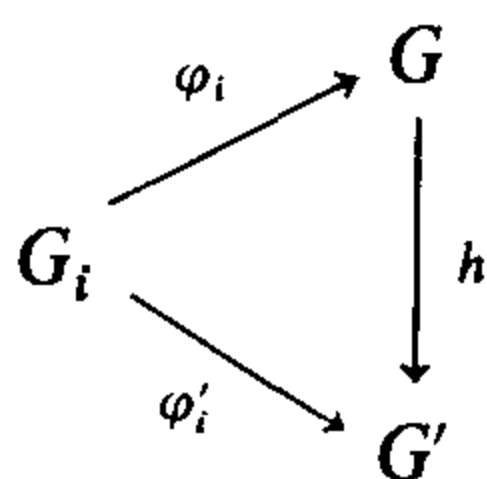

PROOF. The existence of a homomorphism $h: G \rightarrow G'$ making the required diagram commutative is assured by Theorem 2.1. Because Theorem 2.1 also applies to G' and the φ'_i (by hypothesis), there exists a unique homomorphism $k: G' \rightarrow G$ such that the following diagram is commutative for any index $i \in I$:

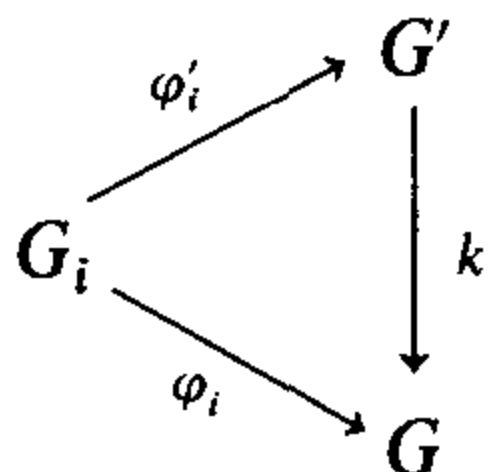

From these facts, we readily conclude that the following two diagrams are commutative for any $i \in I$:

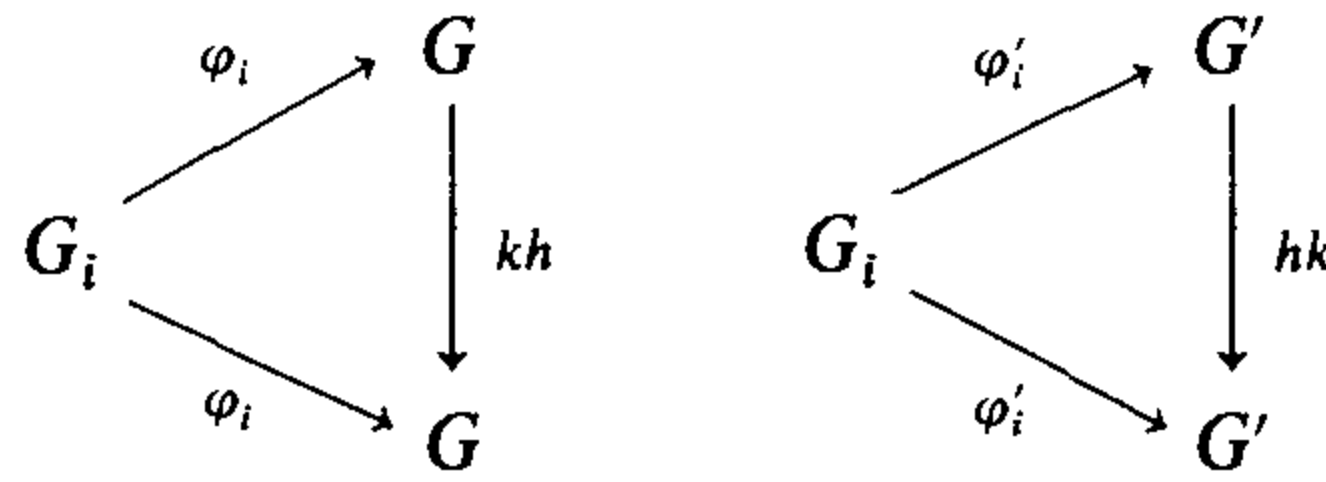

However, these two diagrams would also be commutative if we replaced kh by the identity map $G \rightarrow G$ in the first, and hk by the identity map $G' \rightarrow G'$ in the second. We now invoke the uniqueness statement in the conclusion of Theorem 2.1 to conclude that kh and hk are both identity maps. Hence, h and k are inverse isomorphisms of each other. Q.E.D.

The student should reflect on the significance of the characterization of the weak product given by Theorem 2.1. We may consider any other abelian group A with definite homomorphisms $\psi_i : G_i \rightarrow A$ as a candidate for some kind of a “product” of the abelian groups G_i ; then this theorem asserts that the weak product G is the “freest” among all such candidates in the sense that there exists a homomorphism of G into A commuting with φ_i and ψ_i for all i . Here we use the word “freest” in the sense of “fewest possible relations imposed,” and the general philosophy is that if certain relations hold for the group G , they also hold for any homomorphic image of G ; of course, additional relations may hold for the homomorphic image. This same philosophy also holds for other kinds of algebraic objects, such as rings, etc.

As we shall see, the argument used to prove Proposition 2.2 applies almost verbatim to many other cases.

Since the weak product G of a collection $\{G_i\}$ of abelian groups is completely characterized by the properties of the monomorphisms $\varphi_i : G_i \rightarrow G$ stated in Theorem 2.1, we could just as well ignore the fact that G is a subgroup of the product

$$\prod_{i \in I} G_i$$

and focus our attention instead on the group G and the homomorphisms φ_i . Furthermore, because each φ_i is a monomorphism, we can identify G_i with its image in G under φ_i , and consider φ_i as an inclusion map, if this is convenient. In this case, we say that G is the weak product of the subgroups G_i , it being understood that each φ_i is an inclusion map.

§3. Free Abelian Groups

We recall that, if S is a subset of a group G , then S is said to *generate* G in case every element of G can be written as a product of positive and negative powers of elements of S . (An equivalent condition is the following: S is not contained in any proper subgroup of G .) For example, if G is a cyclic group

of order n ,

$$G = \{x, x^2, x^3, \dots, x^n = 1\},$$

then the set $S = \{x\}$ generates G .

If the set S generates the group G , certain products of elements of S may be the identity element of G . For example,

- (a) If $x \in S$, then $xx^{-1} = 1$.
- (b) If G is a cyclic group of order n generated by $\{x\}$, then $x^n = 1$.

Any such product of elements of S that is equal to the identity is often called a *relation* between the elements of the generating set S . Roughly speaking, we may distinguish between two types of relations between generators: *trivial relations*, as in Example (a), which are a direct consequence of the axioms for a group and thus hold no matter what the choice of G and S , and *nontrivial relations*, such as Example (b), which are not a consequence of the axioms for a group, but depend on the particular choice of G and S .

These notions lead naturally to the following definition: Let S be a set of generators for the group G . We say that G is *freely generated* by S or a *free group* on S in case there are no nontrivial relations between the elements of S . For example, if G is an infinite cyclic group consisting of all positive and negative powers of the element x , then G is a free group on the set $S = \{x\}$.

These notions also lead to the idea that we can completely prescribe a group by listing the elements of a generating set S and listing the nontrivial relations between them.

The ideas described in the preceding paragraphs have been current among group theorists for a long time. Unfortunately, when stated as above, these ideas are lacking in mathematical precision. For example, what precisely is a nontrivial relation? It cannot be an element of G , because considered as elements of G , all relations give the identity. Also, under what conditions are two relations to be considered the same? For example, in a cyclic group of order n , are the relations

$$\begin{aligned}x^n &= 1, \\x^{n+1}x^{-1} &= 1\end{aligned}$$

to be considered the same or different?

We should emphasize that it was not an easy matter for mathematicians to find an entirely satisfactory and precise way of treating these questions. Fortunately, such a treatment has been found in recent years. This treatment has the advantage that it applies not only to groups, but also to other algebraic structures such as rings, and even to many situations in other branches of mathematics. As so often happens in mathematics, the method of definition finally chosen seems rather roundabout and nonobvious.² This method of definition depends on the following rather simple observations:

² An analogous situation occurs in the problem of precisely defining limits in the calculus. The $\varepsilon - \delta$ technique which is standard today seems rather far removed from our intuitive notion of a variable quantity approaching a limit.

(1) Let S be a set of generators for G , and let $f : G \rightarrow G'$ be an epimorphism; i.e., G' is a homomorphic image of G . Then, the set $f(S)$ is a set of generators for G' . Moreover, *any relation which holds between the elements of S also holds between the elements of $f(S)$* . Thus, the group G' satisfies at least as many relations as or more relations than G .

(2) Let S be a set of generators for G , and let $f : G \rightarrow G'$ be an arbitrary homomorphism. Then, f is completely determined by its restriction to the set S . However, we do not assert that any map $g : S \rightarrow G'$ can be extended to a homomorphism $f : G \rightarrow G'$ (the student should give a counterexample). The intuitive reason for this is clear: Given a map $g : S \rightarrow G'$ there may be nontrivial relations between the elements of S which do *not* hold between the elements of $g(S)$.

We shall now give a precise definition of a free *abelian* group on a given set S ; in §5 we shall discuss the case of general (i.e., not necessarily abelian) groups. The case of abelian groups is discussed first because it is simpler.

Definition. Let S be an arbitrary set. A *free abelian group* on the set S is an abelian group F together with a function $\varphi : S \rightarrow F$ such that the following condition holds: For any abelian group A and any function $\psi : S \rightarrow A$, there exists a unique homomorphism $f : F \rightarrow A$ such that the following diagram is commutative:

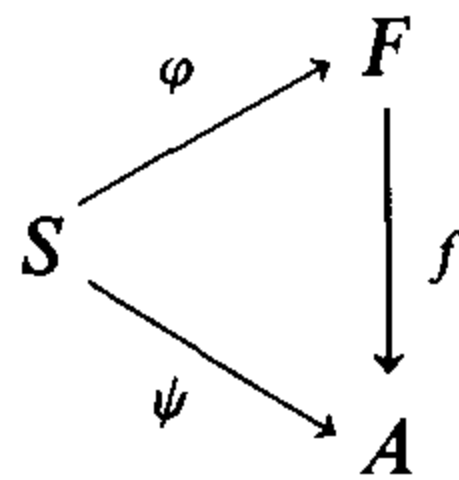

First, we show that this definition does indeed characterize free abelian groups on a given set S .

Proposition 3.1. *Let F and F' be free abelian groups on the set S with respect to the functions $\varphi : S \rightarrow F$ and $\varphi' : S \rightarrow F'$, respectively. Then, there exists a unique isomorphism $h : F \rightarrow F'$ such that the following diagram is commutative:*

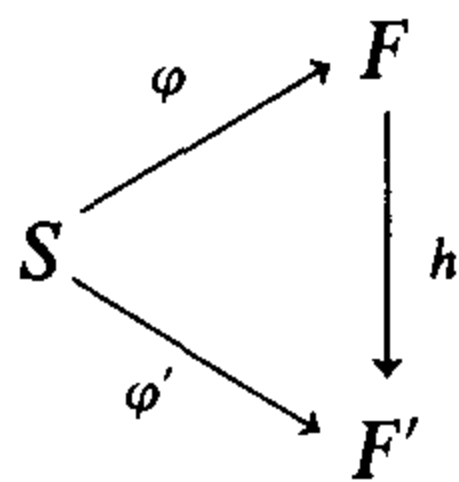

PROOF. The proof is completely analogous to that of Proposition 2.2, and may be left to the reader.

Let us emphasize that all we have done so far is make a definition; given the set S , it is not at all clear that there exists a free abelian group F on the set S . Moreover, even if F exists, it is conceivable that the map φ need not be

one-to-one, or that F may not be generated by the subset $\varphi(S)$ in the sense of the definition at the beginning of this section. We shall clarify all these points by actually proving the existence of F and elucidating its structure completely.

EXERCISES

3.1. Prove directly from the definition that $\varphi(S)$ generates F . [HINT: Assume not; consider the subgroup F' generated by $\varphi(S)$.]

As a first step, we consider the following situation. Assume that $\{S_i : i \in I\}$ is a family of nonempty subsets of S , which are pairwise disjoint and such that

$$S = \bigcup_{i \in I} S_i.$$

For each index $i \in I$, let F_i be a free abelian group on the set S_i with respect to a function $\varphi_i : S_i \rightarrow F_i$. Let F denote the weak product of the groups F_i for all $i \in I$, and let $\eta_i : F_i \rightarrow F$ denote the natural monomorphism. Since the S_i are pairwise disjoint, we can define a function $\varphi : S \rightarrow F$ by the rule

$$\varphi|_{S_i} = \eta_i \varphi_i.$$

Proposition 3.2. *Under the above hypotheses, F is a free abelian group on the set S with respect to the function $\varphi : S \rightarrow F$.*

Roughly speaking, this proposition means that the weak product of any collection of free abelian groups is a free abelian group.

PROOF. Let A be an abelian group and let $\psi : S \rightarrow A$ be a function. We have to prove the existence of a unique homomorphism $f : F \rightarrow A$ such that $\psi = f\varphi$. For each index i , let $\psi_i : S_i \rightarrow A$ denote the restriction of ψ to the subset S_i . Because F_i is a free abelian group on the set S_i , there exists a unique homomorphism $f_i : F_i \rightarrow A$ such that the following diagram is commutative:

$$\begin{array}{ccc} & & F_i \\ & \nearrow \psi_i & \\ S_i & & \\ & \searrow \psi_i & \\ & & A \end{array} \quad \begin{array}{c} \downarrow f_i \\ \\ \end{array} \quad (3.3.1)$$

We now invoke the fundamental property of the weak product of groups contained in Theorem 2.1 to conclude that there exists a unique homomorphism $f : F \rightarrow A$ such that the following diagram is commutative for any index i :

$$\begin{array}{ccc} & & F \\ & \nearrow \eta_i & \\ F_i & & \\ & \searrow f_i & \\ & & A \end{array} \quad \begin{array}{c} \downarrow f \\ \\ \end{array} \quad (3.3.2)$$

We can put these two commutative diagrams together into a single diagram as follows:

$$\begin{array}{ccccc}
 S_i & \xrightarrow{\varphi_i} & F_i & \xrightarrow{\eta_i} & F \\
 & \searrow \psi_i & \downarrow f_i & \swarrow f & \\
 & & A & &
 \end{array} \tag{3.3.3}$$

Because $\varphi|_{S_i} = \eta_i \varphi_i$, we conclude that the following diagram is commutative for each index i .

$$\begin{array}{ccc}
 S_i & \xrightarrow{\varphi_i|_{S_i}} & F \\
 \searrow \psi_i & & \swarrow f \\
 & & A
 \end{array} \tag{3.3.4}$$

Finally, because $\psi_i = \psi|_{S_i}$ for each i and $S = \bigcup S_i$, we conclude that $\psi = f\varphi$, as required.

To prove uniqueness, let f be any homomorphism $F \rightarrow A$ having the required property. Define $f_i: F_i \rightarrow A$ by $f_i = f\eta_i$. With this definition, it follows that diagram (3.3.1) is commutative for each index i ; for,

$$\begin{aligned}
 f_i \varphi_i &= f\eta_i \varphi_i = f(\varphi|_{S_i}) = (\psi|_{S_i}) \\
 &= \psi_i.
 \end{aligned}$$

Because F_i is the free abelian group on S_i (with respect to φ_i), it follows that each f_i is unique. Then because (3.3.2) is commutative for each i , and F is the weak product of the F_i , it follows that f is unique. Q.E.D.

We now apply this theorem as follows: Suppose that

$$S = \{x_i : i \in I\}.$$

For each index i , let S_i denote the subset $\{x_i\}$ having only one element, and let F_i be an infinite cyclic group consisting of all positive and negative powers of the element x_i :

$$F_i = \{x_i^n : n \in \mathbf{Z}\}.$$

Let $\varphi_i: S_i \rightarrow F_i$ denote the inclusion map, i.e., $\varphi_i(x_i) = x_i^1$. It is clear that F_i is a free abelian group on the set S_i . Therefore, all the hypotheses of Proposition 3.2 are satisfied. Thus, we conclude that a free abelian group on any set S is a weak product of a collection of infinite cyclic groups, with the cardinal number of the collection equal to that of S .

Because F is the weak product of the F_i , any element $g \in F$ is of the following form: For any index i , the i th component $g_i = x_i^{n_i}$ where each $n_i \in \mathbf{Z}$ and $n_i = 0$ for all but a finite number of indices i . Moreover, the function φ is defined by the following rule: For any index $j \in I$,

$$(\varphi x_i)_j = \begin{cases} x_i^1 & \text{if } i = j \\ x_j^0 & \text{if } i \neq j. \end{cases}$$

From this formula, it is clear that φ is a one-to-one map.

As φ is a one-to-one map, if we wish, we can identify each $x_i \in S$ with its image $\varphi(x_i) \in F$. Then S becomes a subset of F , and it is clear that we can express each element $g \neq 1$ of F uniquely in the following form:

$$g = x_{i_1}^{n_1} x_{i_2}^{n_2} \cdots x_{i_k}^{n_k}, \quad (3.3.5)$$

where the indices i_1, i_2, \dots, i_k are all distinct, and n_1, n_2, \dots, n_k are nonzero integers. This expression for the element g is unique except for the order of the factors. Moreover, each such product of the x_i 's represents a unique element $g \neq 1$ of F . From this it is clear that F is generated by the subset $S = \varphi(S)$.

This identification of S and $\varphi(S)$ is quite customary in the discussion of free abelian groups. When this is done, $\varphi : S \rightarrow F$ becomes an inclusion map, and often it is not even mentioned in the discussion.

An alternative approach to the topic of free abelian groups would be to *define* an abelian group F to be free on the subset $\{x_i : i \in I\} \subset F$ if every element $g \neq 1$ of F admits an expression of the form (3.3.5), which is unique up to order of the factors. Actually, this procedure would be somewhat quicker and easier than the one we have chosen. However, it would suffer from the disadvantage that it could not be generalized to non-abelian groups and other situations which will actually be our main concern.

One reason for the importance of free abelian groups is the following proposition.

Proposition 3.3. *Any abelian group is the homomorphic image of a free abelian group; i.e., given any abelian group A , there exists a free abelian group F and an epimorphism $f : F \rightarrow A$.*

PROOF. The proof is very simple. Let $S \subset A$ be a set of generators for A (e.g., we could take $S = A$), and let F be a free group on the set S with respect to a function $\varphi : S \rightarrow F$. Let $\psi : S \rightarrow A$ denote the inclusion map. By definition, there exists a homomorphism $f : F \rightarrow A$ such that $f\varphi = \psi$. It is clear that f must be an epimorphism, since S was chosen to be a set of generators for A .

Q.E.D.

This proposition enables us to attach a precise meaning to the notion "nontrivial relation between the generators S ," mentioned earlier. Let A, S, F , and f have the meaning just described; then we define any element $r \neq 1$ of kernel f to be a nontrivial relation between the set of generators S . If $\{r_i : i \in I\}$ is any collection of such relations, and r is an element of the subgroup of F generated by the r_i 's, then the relation r is said to be a *consequence* of the relations r_i . This implies that r can be expressed as a product of the r_i 's and

their inverses. If the collection $\{r_i : i \in I\}$ generates the kernel of f , then the group A is completely determined up to isomorphism by the set of generators S and the set of relations $\{r_i : i \in I\}$; A is isomorphic to the quotient group of F modulo the subgroup generated by the r_i 's.

It is clear that, if S and S' are sets having the same cardinal number, and F and F' are free abelian groups on S and S' , respectively, then F and F' are isomorphic. We shall now show that the converse of this statement is true, at least for the case of finite sets. For this purpose, we make the following definition. If G is any group, and n is any positive integer, then G^n denotes the subgroup of G generated by the set

$$\{g^n : g \in G\}.$$

If the group G is abelian, then the set $\{g^n : g \in G\}$ is actually already a subgroup.

Lemma 3.4. *Let F be a free abelian group on a set consisting of k elements. Then, the quotient group F/F^n is a finite group of order n^k .*

PROOF. We leave the proof to the reader; it is not difficult if one makes use of the explicit structure of free abelian groups described above.

Corollary 3.5. *Let S and S' be finite sets whose cardinals are not equal, and let F and F' be free abelian groups on S and S' , respectively. Then, F and F' are nonisomorphic.*

PROOF. The proof is by contradiction. Any isomorphism between F and F' would induce an isomorphism between the quotient groups F/F^n and F'/F'^n , which is impossible by the lemma.

EXERCISES

3.2. Prove that the statement of this corollary is still true if S is a finite set and S' is an infinite set.

Let F be a free abelian group on a set S . The cardinal number of the set S is called the *rank* of F . We have proved that *two free abelian groups are isomorphic if and only if they have the same rank*, at least in the case where one of them has finite rank.

We shall conclude this section on abelian groups with a brief discussion of the structure of finitely generated abelian groups. Let A be an abelian group; the set of all elements of A which have finite order is readily seen to be a subgroup, called the *torsion subgroup* of A . When the torsion subgroup consists of the element 1 alone, A is called a *torsion-free* abelian group. On the other hand, if every element of A has finite order, then A is called a torsion group. If we denote the torsion subgroup by T , then the quotient group A/T

is obviously torsion free. It is clear that, if A and A' are isomorphic, then so are their torsion subgroups, T and T' , and their torsion-free quotient groups, A/T and A'/T' . However, the converse is not true in general; we cannot conclude that A is isomorphic to A' if $T \approx T'$ and $A/T \approx A'/T'$. However, for abelian groups which are generated by a finite subset we have the following theorem which describes their structure completely:

Theorem 3.6. (a) *Let A be a finitely generated abelian group and let T be its torsion subgroup. Then, T and A/T are also finitely generated, and A is isomorphic to the direct product $T \times A/T$. Hence, the structure of A is completely determined by its torsion subgroup T and its torsion-free quotient group A/T .* (b) *Every finitely generated torsion-free abelian group is a free abelian group of finite rank.* (c) *Every finitely generated torsion abelian group T is isomorphic to a product $C_1 \times C_2 \times \cdots \times C_n$, where each C_i is a finite cyclic group of order ε_i such that ε_i is a divisor of ε_{i+1} for $i = 1, 2, \dots, n - 1$. Moreover, the integers $\varepsilon_1, \varepsilon_2, \dots, \varepsilon_n$ are uniquely determined by the torsion group T and they completely determine its structure.*

The numbers $\varepsilon_1, \dots, \varepsilon_n$ are called the *torsion coefficients* of T , or more generally, if T is the torsion subgroup of A , they are called the torsion coefficients of A . Similarly, the rank of the free group A/T is called the rank of A . With this terminology, we can summarize Theorem 3.6 by stating that the rank and torsion coefficients are a complete set of invariants of a finitely generated abelian group. Theorem 3.6 asserts that every finitely generated abelian group is a direct product of cyclic groups, but it also asserts much more. Note that a finitely generated torsion group is actually of finite order.

A word of explanation about the various isomorphisms mentioned in Theorem 3.6 seems in order here. These isomorphisms are not *natural*, or uniquely determined in any way. In each case, there are usually many different choices for the isomorphism in question and one choice is as good as another.

Theorem 3.7. *Let F be a free abelian group on a set S , and let F' be a subgroup of F . Then, F' is a free abelian group on a certain set S' , and the cardinal of S' is less than or equal to that of S .*

Although the proofs of Theorems 3.6 and 3.7 are not difficult, we shall not give them here, because they properly belong in the study of linear algebra and modules over a principal ideal domain.

EXERCISES

- 3.3. Give an example of a torsion-free abelian group which is not free.
- 3.4. Let A be an abelian group which is a direct product of two cyclic groups of orders 12 and 18, respectively. What are the torsion coefficients of A ? (Note that the torsion coefficients are required to satisfy a divisibility condition.)

3.5. Give an example to show that in Theorem 3.7 the subset $S \subset F$ and the subgroup $F' \subset F$ may be disjoint, even in the case where the cardinals of S and S' are equal.

§4. Free Products of Groups

The free product of a collection of groups is the exact analog for arbitrary (i.e., not necessarily abelian) groups of the weak product for abelian groups. (It should be emphasized that any groups considered in this section may be either abelian or non-abelian, unless the contrary is explicitly stated.)

Definition. Let $\{G_i : i \in I\}$ be a collection of groups, and assume there is given for each index i a homomorphism φ_i of G_i into a fixed group G . We say that G is the *free product* or *coproduct* of the groups G_i (with respect to the homomorphisms φ_i) if and only if the following condition holds: For any group H and any homomorphisms

$$\psi_i : G_i \rightarrow H, \quad i \in I,$$

there exists a unique homomorphism $f : G \rightarrow H$ such that for any $i \in I$, the following diagram is commutative:

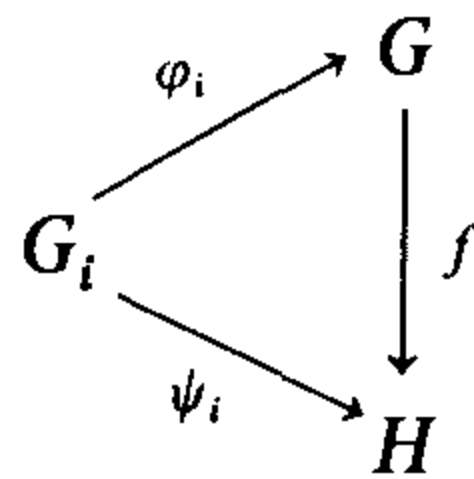

First, we have the following uniqueness proposition about free products:

Proposition 4.1. Assume that G and G' are free products of a collection $\{G_i : i \in I\}$ of groups (with respect to homomorphisms $\varphi_i : G_i \rightarrow G$ and $\varphi'_i : G_i \rightarrow G'$, respectively). Then, there exists a unique isomorphism $h : G \rightarrow G'$ such that the following diagram is commutative for any $i \in I$:

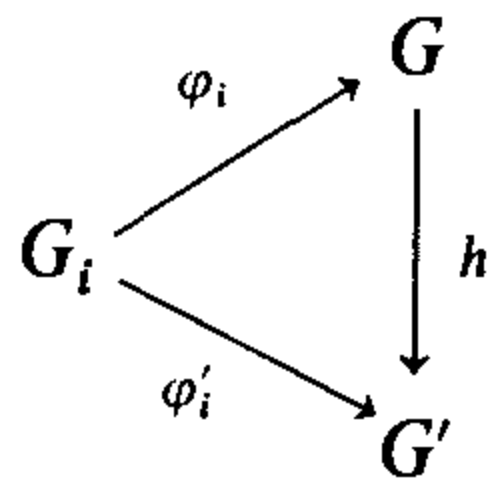

PROOF. The proof is almost word for word that of Proposition 2.2.

Although we have defined free products of groups and proved their uniqueness, it still remains to prove that they always exist. We shall also show that each of the homomorphisms φ_i occurring in the definition is a monomorphism,

that the free product is generated by the union of the images $\varphi_i(G_i)$, and get more detailed insight into the algebraic structure of a free product.

Theorem 4.2. *Given any collection $\{G_i : i \in I\}$ of groups, their free product exists.*

PROOF. We define a *word* in the G_i 's to be a finite sequence (x_1, x_2, \dots, x_n) where each x_k belongs to one of the groups G_i , any two successive terms in the sequence belong to different groups, and no term is the identity element of any G_i . The integer n is the *length* of the word. We also include the empty word, i.e., the unique word of length 0. Let W denote the set of all such words.

For each index i , we now define left operations of the group G_i on the set W (see Appendix B). Let $g \in G_i$ and $(x_1, \dots, x_n) \in W$; we must define $g(x_1, \dots, x_n)$.

Case 1: $x_1 \notin G_i$. Then, if $g \neq 1$,

$$g(x_1, \dots, x_n) = (g, x_1, \dots, x_n).$$

We shall also define the action of g on the empty word by a similar formula, i.e., $g(\) = (g)$. If $g = 1$, then,

$$g(x_1, \dots, x_n) = (x_1, \dots, x_n).$$

Case 2: $x_1 \in G_i$. Then,

$$g(x_1, \dots, x_n) = \begin{cases} (gx_1, x_2, \dots, x_n) & \text{if } gx_1 \neq 1 \\ (x_2, \dots, x_n) & \text{if } gx_1 = 1. \end{cases}$$

[When $gx_1 = 1$ and $n = 1$, it is understood, of course, that $g(x_1)$ is the empty word.]

We must now verify that the requirements for left operations of G_i on W are actually satisfied; i.e., for any word w ,

$$1w = w,$$

$$(gg')w = g(g'w).$$

This verification is a trivial checking of various cases.

It is clear that each of the groups G_i acts effectively. Thus, each element g of G_i may be considered as a permutation of the set W , and G_i may be considered as a subgroup of the group of all permutations of W (see Appendix B). Let G denote the subgroup of the group of all permutations of W which is generated by the union of the G_i 's. Then, G contains each G_i as a subgroup; we let

$$\varphi_i : G_i \rightarrow G$$

denote the inclusion map.

Any element of G may be expressed as a finite product of elements from the various G_i 's. If two consecutive factors in this product come from the same G_i , it is clear that they may be replaced by a single factor. Thus, any element

$g \neq 1$ of G may be expressed as a finite product of elements from the G_i 's in *reduced form*, i.e., so no two consecutive factors belong to the same group, and so no factor is the identity element. We now assert that *the expression of any element $g \neq 1$ of G in reduced form is unique*: If

$$g = g_1 g_2 \cdots g_m = h_1 h_2 \cdots h_n$$

with both products in reduced form, then $m = n$ and $g_i = h_i$ for $1 \leq i \leq m$. To see this, consider the effect of the permutations $g_1 g_2 \cdots g_m$ and $h_1 h_2 \cdots h_n$ on the empty word; the results are the words (g_1, g_2, \dots, g_m) and (h_1, h_2, \dots, h_n) , respectively. Because these two words must be equal, the conclusion follows.

It is clear how to form the inverse of an element of G written in reduced form, and how to form the product of two such elements.

It is now an easy matter to verify that G is actually the free product of the G_i 's with respect to the φ_i 's. For, let H be any group and let $\psi_i: G_i \rightarrow H$, $i \in I$, be any collection of homomorphisms. Define a function $f: G \rightarrow H$ as follows. Express any given $g \neq 1$ in reduced form,

$$g = g_1 g_2 \cdots g_m, \quad g_k \in G_{i_k}, \quad 1 \leq k \leq m,$$

and then set

$$f(g) = (\psi_{i_1} g_1)(\psi_{i_2} g_2) \cdots (\psi_{i_m} g_m).$$

We also set $f(1) = 1$, of course. It is clear that f is a homomorphism, and that f makes the required diagrams commutative. It is also clear that f is the only homomorphism that makes these diagrams commutative. Q.E.D.

Because the homomorphisms $\varphi_i: G_i \rightarrow G$ are monomorphisms, it is customary to identify each group G_i with its image under φ_i , and to regard it as a subgroup of the free product G . Then, φ_i becomes an inclusion map, and it is not usually necessary to mention it explicitly.

The two most important facts to remember from the proof of Theorem 4.2 are the following:

- (a) Any element $g \neq 1$ of the free product can be expressed uniquely as a product in reduced form of elements from the groups G_i .
- (b) The rules for multiplying two such products in reduced form (or for forming their inverses) are the obvious and natural ones.

These facts give one great insight into the structure of a free product of groups.

Examples

4.1. Let G_1 and G_2 be cyclic groups of order 2, $G_1 = \{1, x_1\}$ and $G_2 = \{1, x_2\}$. Then, any element $g \neq 1$ of their free product can be written uniquely as a product of x_1 and x_2 , with the factors x_1 and x_2 alternating. For example, the following are such elements:

$$x_1, x_1 x_2, x_1 x_2 x_1, x_1 x_2 x_1 x_2, \text{ etc.,}$$

or

$$x_2, x_2x_1, x_2x_1x_2, x_2x_1x_2x_1, \text{ etc.}$$

Note that the elements x_1x_2 and x_2x_1 are both of infinite order, and they are different. Note also the great difference between the direct product or weak product of G_1 and G_2 and their free product in this case. The direct product is an abelian group of order 4, whereas the free product is a non-abelian group with elements of infinite order.

Notation: We denote the free product of groups G_1, G_2, \dots, G_n by $G_1 * G_2 * \dots * G_n$ or

$$\prod_{1 \leq i \leq n}^* G_i.$$

The free product of the family of groups $\{G_i : i \in I\}$ is denoted by

$$\prod_{i \in I}^* G_i.$$

EXERCISES

- 4.1. Let $\{G_i : i \in I\}$ be a collection containing more than one group, each of which has more than one element. Prove that their free product is non-abelian, contains elements of infinite order, and that its center consists of the identity element alone.
- 4.2. For each index i , let G'_i be a subgroup of G_i (proper or improper). Prove that the free product of the collection $\{G'_i : i \in I\}$ may be considered as a subgroup of the free product of the G_i .
- 4.3. Let $\{G_i : i \in I\}$ and $\{G'_i : i \in I\}$ be two families of groups indexed by the same set I . Assume that for each index $i \in I$ there is given a homomorphism $f_i : G_i \rightarrow G'_i$. Prove that there exists a unique homomorphism $f : G \rightarrow G'$ of the free product of the first family of groups into the free product of the second family such that the following diagram is commutative for each index i :

$$\begin{array}{ccc} G_i & \xrightarrow{\varphi_i} & G \\ f_i \downarrow & & \downarrow f \\ G'_i & \xrightarrow{\varphi'_i} & G' \end{array}$$

Show that if each f_i is a monomorphism (respectively, epimorphism), then f is a monomorphism (respectively, epimorphism).

- 4.4. Prove that if an element x of the free product $G * H$ has finite order, then x is an element of G or H , or is conjugate to an element of G or H . (HINT: Express x as a word in reduced form; then make the proof by induction on the length of the word.) Deduce that if G and H are cyclic groups of orders m and n , respectively, where $m > 1$ and $n > 1$, then the maximum order of any element of $G * H$ is $\max(m, n)$.

- 4.5.** Let $\{G_i : i \in I\}$ be a collection of abelian groups, and let G be their free product with respect to homomorphisms $\varphi_i : G_i \rightarrow G$. Let $G' = G/[G, G]$ be the quotient of G by its commutator³ subgroup and let $\varphi'_i : G_i \rightarrow G'$ be the composition of φ_i with the natural homomorphism $G \rightarrow G'$. Prove that G' is a weak product of the groups $\{G_i\}$ with respect to the homomorphisms φ'_i (i.e., the conclusion of Proposition 2.1 holds).
- 4.6.** Let $G, H, G',$ and H' be cyclic groups of orders $m, n, m',$ and $n',$ respectively. If $G * H$ is isomorphic to $G' * H'$, then $m = m'$ and $n = n'$ or else $m = n'$ and $n = m'$. (HINT: Apply Exercise 4.5 to $G * H$ and $G' * H'$; thus we see that, if we “abelianize” $G * H$ and $G' * H'$, we obtain finite abelian groups of orders mn and $m'n'$, respectively. Now apply Exercise 4.4.)
- 4.7.** Let H and H' be conjugate subgroups of G . Prove that if f is any homomorphism of G into some other group such that $f(H) = 1$, then $f(H') = 1$ also.
- 4.8.** Let G be the free product of the family of groups $\{G_i : i \in I\}$, where it is assumed that $G_i \neq \{1\}$ for any index i . Prove that, for any two distinct indices i and $i' \in I$, the subgroups G_i and $G_{i'}$ of G are not conjugate. (HINT: Apply Exercise 4.7. Use Exercise 4.3 to construct a homomorphism f of G into another free product with the required properties.)
- 4.9.** Let $G = G_1 * G_2$, and let N be the least normal subgroup of G which contains G_1 . Prove that G/N is isomorphic to G_2 . (HINT: Use Exercise 4.3. Let $G'_1 = \{1\}$, $G'_2 = G_2$, $f_1 : G_1 \rightarrow G'_1$ be the trivial homomorphism, and let $f_2 : G_2 \rightarrow G'_2$ be the identity map. Prove that N is the kernel of the induced homomorphism $f : G \rightarrow G'$.)
- 4.10.** Let G admit two different decompositions as a free product:

$$G = G_0 * \left(\prod_{i \in I}^* G_i \right) = H_0 * \left(\prod_{i \in I}^* H_i \right)$$

with the same index set I . Assume that, for each index $i \in I$, G_i and H_i are conjugate subgroups of G . Prove that G_0 and H_0 are isomorphic. (HINT: The method of proof is similar to that of Exercise 4.9.)

§5. Free Groups

As the reader may have guessed, the definition of a free group is entirely analogous to that of a free abelian group.

Definition. Let S be an arbitrary set. A *free group on the set S* (or a *free group generated by S*) is a group F together with a function $\varphi : S \rightarrow F$ such that the following condition holds: For any group H and any function $\psi : S \rightarrow H$, there exists a unique homomorphism $f : F \rightarrow H$ such that the following diagram is

³ This terminology and notation is explained in the following section just before the statement of Proposition 5.3.

commutative:

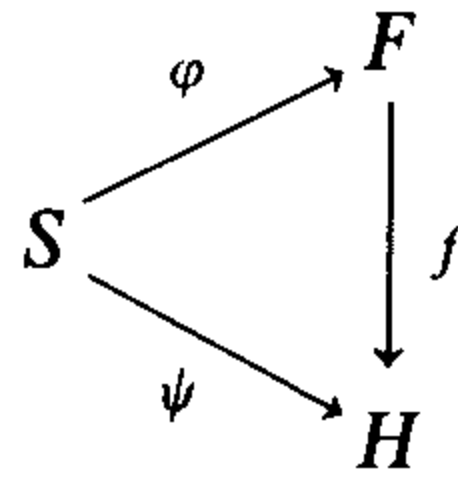

Exactly as in the previous cases we have encountered, this definition completely characterizes a free group. To be precise:

Proposition 5.1. *Let F and F' be free groups on the set S with respect to functions $\varphi : S \rightarrow F$ and $\varphi' : S \rightarrow F'$, respectively. Then, there exists a unique isomorphism $h : F \rightarrow F'$ such that the following diagram is commutative:*

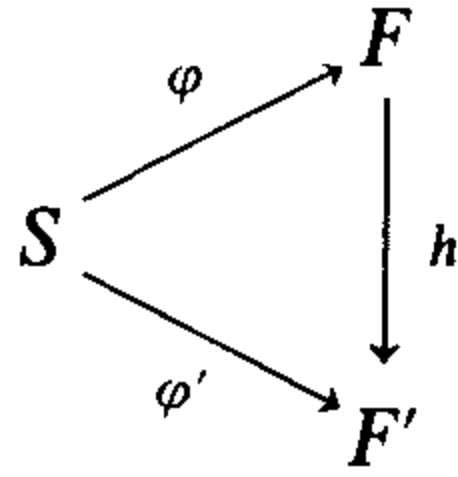

It still remains to prove that, given any set S , there exists a free group on the set S , and to establish its principal properties. We shall do this by exactly the same method as that used for the case of free abelian groups.

Assume, then, that

$$S = \bigcup_{i \in I} S_i,$$

where the subsets S_i are disjoint and nonempty. For each index i , let F_i be a free group on the set S_i with respect to a function $\varphi_i : S_i \rightarrow F_i$. Let F denote the free product of the groups F_i with respect to homomorphisms $\eta_i : F_i \rightarrow F$ (recall that we have proved that each η_i is actually a monomorphism!). Because the subsets S_i are pairwise disjoint, we can define a function $\varphi : S \rightarrow F$ by the rule

$$\varphi|_{S_i} = \eta_i \varphi_i.$$

Proposition 5.2. *Under the above hypotheses, F is the free group on the set S with respect to the function $\varphi : S \rightarrow F$.*

The proof of this proposition is the same as that of Proposition 3.2 except for obvious modifications. Hence, it is not necessary to go through these details again. This proposition may be restated as follows: The free product of any collection of free groups is a free group.

We shall now apply this proposition to prove the existence of free groups exactly as we applied Proposition 3.2 to prove the existence of free abelian

groups. The details are as follows: Let $S = \{x_i : i \in I\}$ be an arbitrary nonempty set, and, for each index i , let $S_i = \{x_i\}$. Let f_i denote an infinite cyclic group generated by x_i ,

$$F_i = \{x_i^n : n \in \mathbf{Z}\},$$

and let $\varphi : S_i \rightarrow F_i$ denote the inclusion map. Then, F_i is readily seen to be a free group on the set S_i with respect to the map φ_i (as we shall see later, this case, where S has only one element, is the only one where the free group on a set S and the free abelian group on S are the same). The hypotheses of Proposition 5.2 are all satisfied; we conclude that F is a free group on the set S with respect to the function $\varphi : S \rightarrow F$. Note that F is a free product of infinite cyclic groups. From what we have learned about free products, we see that *every element $g \neq 1$ of the free group F can be expressed uniquely in the form*

$$g = x_1^{n_1} x_2^{n_2} \cdots x_k^{n_k},$$

where x_1, x_2, \dots, x_k are elements of S such that any two successive elements are different, and n_1, n_2, \dots, n_k are nonzero integers, positive or negative. Such an expression for g is called a *reduced word* in the elements of S . To avoid exceptions, we say that the identity 1 is represented by the *empty word*. The rules for forming inverses and products of reduced words are the obvious ones.

From these facts, it is clear that the function $\varphi : S \rightarrow F$ is one-to-one, and that F is actually generated by the subset $\varphi(S)$ in the sense defined earlier.

In many cases it is convenient to take S to be a subset of F and φ to be the inclusion map. If this is the case, we may as well omit any mention of φ .

EXERCISES

- 5.1. Prove that a free group on a nonempty set S is abelian if and only if S has exactly one element.
- 5.2. Prove that the center of a free group on a set having more than one element consists of the identity element alone.
- 5.3. Let g and h be two elements of a free group on a set S having more than one element. Give a necessary and sufficient condition for g and h to be conjugate in terms of their expressions as reduced words. (HINT: Consider cyclic permutations of the factors of a reduced word.)

We shall conclude this section by considering the relation between free groups and free abelian groups. Recall that, if x and y are any two elements of a group G , the notation $[x, y]$ denotes the element $xyx^{-1}y^{-1} \in G$, and it is called the *commutator* of x and y (in the given order). The notation $[G, G]$ denotes the subgroup of G generated by all commutators; it is called the *commutator* subgroup and is readily verified to be a normal subgroup. The quotient group $G/[G, G]$ is abelian. Conversely, if N is any normal subgroup of G such that G/N is abelian, then $N \supseteq [G, G]$.

Proposition 5.3. *Let F be a free group on the set S with respect to a function $\varphi : S \rightarrow F$, and let $\pi : F \rightarrow F/[F, F]$ denote the natural projection of F onto the quotient group. Then, $F/[F, F]$ is a free abelian group on S with respect to the function $\pi\varphi : S \rightarrow F/[F, F]$.*

The proof is a nice exercise in the use of the definitions and the facts stated in the preceding paragraph.

Corollary 5.4. *If F and F' are free groups on finite sets S and S' , then F and F' are isomorphic if and only if S and S' have the same cardinal number.*

PROOF. Any isomorphism of F onto F' would induce an isomorphism of the quotient groups, $F/[F, F]$ and $F'/[F', F']$. We now reach a contradiction by using the preceding proposition and Corollary 3.5. This proves the “only if” part of the corollary. The proof of the “if” part is trivial.

EXERCISES

5.4. Prove that this corollary is still true if S is a finite set and S is an arbitrary set.

If F is a free group on a set S , the cardinal number of S is called the *rank* of F . Corollary 5.4 shows that the rank is an invariant of the group at least in the case of free groups of finite rank. It can also be proved that the rank of a free group is an invariant even in the case where it is an infinite cardinal. The proof is more of an exercise in the arithmetic of cardinal numbers than in group theory, and we shall not give it here.

If F is a free group on the set S with respect to the function $\varphi : S \rightarrow F$, because φ is one-to-one it is usually convenient to consider S as a subset of F and φ as an inclusion map, as we mentioned above. With this convention, S is called a *basis* for F . In other words, a basis for F is any subset S of F such that F is a free group on S with respect to the inclusion map $S \rightarrow F$. A free group has many different bases.

§6. The Presentation of Groups by Generators and Relations

We begin with a result that is the analog for arbitrary groups of Proposition 3.3.

Proposition 6.1. *Any group is the homomorphic image of a free group. To be precise, if S is any set of generators for the group G , and F is a free group on S , then the inclusion map $S \rightarrow G$ determines a unique epimorphism of F onto G .*

The proof is the same as that of Proposition 3.3. This proposition enables us to give a mathematically precise meaning to the term “nontrivial relation between generators” by a method analogous to that used in the case of abelian groups. There is one slight difference between the abelian case and the present case because, in the case of abelian groups, any subgroup can be the kernel of a homomorphism, whereas in the case of non-abelian groups, only a *normal* subgroup can be a kernel. For this reason we shall give a complete discussion of this case.

Let S be a set of generators for the group G let F be a free group on the set S with respect to a map $\varphi : S \rightarrow F$, let $\psi : S \rightarrow G$ be the inclusion map, and let $f : F \rightarrow G$ be the unique homomorphism such that $f\varphi = \psi$. Any element $r \neq 1$ of the kernel of f is (by definition) a *relation* between the generators of S for the group G . In view of what we have proved, r can be expressed uniquely as a reduced word in the elements of S . Because every element of S is also an element of G , this reduced word can also be considered as a product in G ; however, in G , this product reduces to the identity element. Thus, by this device of introducing the free group F on the set S , we have given the relation r a “place to live,” to use a figure of speech. If $\{r_j\}$ is any collection of relations, then any other relation r is said to be a *consequence* of the relations r_j if and only if r is contained in the least *normal* subgroup of F which contains the relation r_j . In the case where every relation is a consequence of the set of relations $\{r_j\}$, the kernel of f is completely determined by the set $\{r_j\}$; it is the intersection of all *normal* subgroups of F which contain the set $\{r_j\}$. In this case, the group G is completely determined up to isomorphism by the set of generators S and the set of relations $\{r_j\}$, because it is isomorphic to the quotient of F modulo the least normal subgroup containing the set $\{r_j\}$. Such a set of relations is called a *complete* set of relations.

Definition. A *presentation* of a group G is a pair $(S, \{r_j\})$ consisting of a set of generators for G and a complete set of relations between these generators. The presentation is said to be *finite* in case both S and $\{r_j\}$ are finite sets, and the group G is said to be *finitely presented* in case it has at least one finite presentation.

Let us emphasize that any group admits many different presentations, which may look quite different. Conversely, given two presentations $(S, \{r_j\})$ and $(S', \{r'_k\})$, it is often nearly impossible to determine whether or not the two groups thus defined are isomorphic.

Examples

6.1. A cyclic group of order n admits a presentation with one generator x and one relation x^n .

6.2. We shall prove later that the fundamental group of the Klein bottle admits the following two different presentations (among others):

- (a) Two generators a and b and one relation $baba^{-1}$.
 (b) Two generators a and c and one relation a^2c^2 .

The relationship between the two presentations in this case is fairly simple: $c = ba^{-1}$ or $b = ca$. To be precise, let $F(a, b)$ and $F(a, c)$ denote free groups on the sets $\{a, b\}$ and $\{a, c\}$, respectively. Define homomorphisms $f: F(a, b) \rightarrow F(a, c)$ and $g: F(a, c) \rightarrow F(a, b)$ by the following conditions:

$$\begin{aligned} f(a) &= a, & f(b) &= ca, \\ g(a) &= a, & g(c) &= ba^{-1}. \end{aligned}$$

It follows directly from the definition of a free group that these equations define unique homomorphisms. We compute that

$$\begin{aligned} g[f(a)] &= a, & g[f(b)] &= b, \\ f[g(a)] &= a, & f[g(c)] &= c. \end{aligned}$$

Therefore, gf is the identity map of $F(a, b)$, and fg is the identity map of $F(a, c)$. Hence, f and g are isomorphisms which are the inverse of each other. Next, we check that

$$\begin{aligned} a^2c^2 &= c^{-1}[f(baba^{-1})]c, \\ baba^{-1} &= (ba^{-1})[g(a^2c^2)](ba^{-1})^{-1}. \end{aligned}$$

Therefore, the normal subgroup of $F(a, b)$, generated by $baba^{-1}$, and the normal subgroup of $F(a, c)$, generated by a^2c^2 , correspond under the isomorphisms f and g . Hence, f and g induce isomorphisms of the corresponding quotient groups.

Note that the essence of the above argument is contained in the following two simple calculations:

- (a) If $b = ca$, then $baba^{-1} = ca^2c$ and $a^2c^2 = c^{-1}[baba^{-1}]c$.
 (b) If $c = ba^{-1}$, then $a^2c^2 = a^2ba^{-1}ba^{-1}$ and $baba^{-1} = (ba^{-1})(a^2c^2)(ba^{-1})^{-1}$.

6.3. Consider the following two group presentations:

- (a) Two generators a and b and one relation a^3b^{-2} .
 (b) Two generators x and y and one relation $xyxy^{-1}x^{-1}y^{-1}$.

We assert that these are presentations of isomorphic groups. The relationship between the two different pairs of generators is given by the following system of equations:

$$\begin{aligned} a &= xy, & b &= xyx, \\ x &= a^{-1}b, & y &= b^{-1}a^2. \end{aligned}$$

We leave it to the reader to work out the details. We shall see in Section IV.6 that this is a presentation of the fundamental group of the complement of a certain knotted circle in Euclidean 3-space.

In dealing with groups presented by means of generators and relations, it is often convenient to take a more informal approach. To illustrate what we mean, consider the first presentation in Example 6.3. The group G under consideration is the quotient of a free group F on two generators a and b by the least normal subgroup containing the element a^3b^{-2} . Let us denote the image of the generators a and b in the group G by the same symbols. Then, $a^3b^{-2} = 1$ in G , or $a^3 = b^2$. When computing with elements of G (which are products of powers of a and b) we can use the equation $a^3 = b^2$ in whatever way is convenient.

EXERCISES

- 6.1. Suppose we are given presentations of two groups G_1 and G_2 by means of generators and relations. Show how to obtain from this a presentation of the direct product $G_1 \times G_2$, the free product $G_1 * G_2$, and the commutator quotient group $G_1/[G_1, G_1]$.

§7. Universal Mapping Problems

In the preceding sections of this chapter we have defined and studied the following types of algebraic objects: weak products of abelian groups, free abelian groups, free products of groups, and free groups. In each of these cases, the algebraic object in question was actually a system consisting of two things with a mapping between them, e.g., $\varphi : S \rightarrow G$. This system consisting of two things and a mapping between them was characterized by a certain triangular diagram, e.g.,

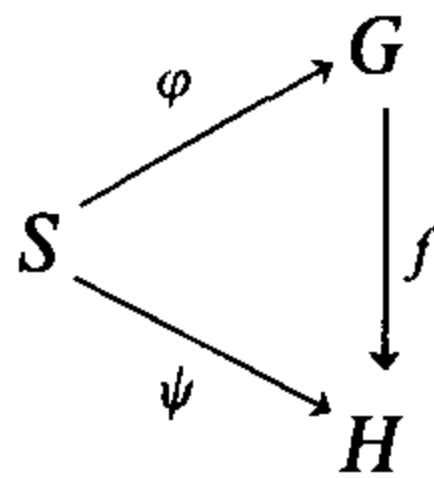

As the reader will recall, the object H and the map ψ in this diagram could be chosen in a fairly arbitrary manner, subject only to minor restrictions. It was then required that there exist a unique map f making the diagram commutative.

This method of characterizing the system $\varphi : S \rightarrow G$ is usually referred to by the statement that $\varphi : S \rightarrow G$ (or for brevity, G) is the solution of a “universal mapping problem.” We shall see another important example of such a universal mapping problem in the next chapter. Defining or characterizing mathematical objects as the solution to a universal mapping problem has become very common in recent years. For example, one of the most prominent contemporary algebraists (C. Chevalley) has written a textbook on algebra [6] that has universal mapping problems as one of its main themes.

If a mathematical object is defined or characterized as being the solution to a universal mapping problem, it follows easily (by the method used to prove Proposition 2.2) that this object is unique up to an isomorphism. In fact, the isomorphism is even uniquely determined! However, the *existence* of an object satisfying a given universal mapping problem is another question. The reader will note that in the four cases discussed in this chapter, at least three different constructions were given to prove the existence of a solution. However, in each case, the existence proof carried with it a bonus, in that it gave great insight into the actual structure of the desired mathematical object.

There exists a rather general method for proving the existence of solutions of universal mapping problems (see [5], [7]). However, this general method gives absolutely no insight into the mathematical structure of the solution. It is a pure existence proof.

We now give two more examples of the characterization of mathematical objects as solutions of universal mapping problems. The examples are given for illustrative purposes only and will not be used in any of the succeeding chapters.

Examples

7.1. Free commutative ring with a unit. Let $\mathbf{Z}[x_1, x_2, \dots, x_n]$ denote, as usual, the ring of all polynomials with integral coefficients in the “variables” or “indeterminates” x_1, x_2, \dots, x_n . Each nonzero element of this ring can be expressed uniquely as a finite linear combination with integral coefficients of the monomials $x_1^{k_1} x_2^{k_2} \dots x_n^{k_n}$, where k_1, k_2, \dots, k_n are non-negative integers. This ring may be considered to be the free commutative ring with unit generated by the set $S = \{x_1, \dots, x_n\}$. We make this assertion precise, as follows: Let $\varphi : S \rightarrow \mathbf{Z}[x_1, \dots, x_n]$ denote the inclusion map. Then, for any commutative ring R (with unit) and any function $\psi : S \rightarrow R$, there exists a unique ring homomorphism $f : \mathbf{Z}[x_1, \dots, x_n] \rightarrow R$ [with $f(1) = 1$] such that the following diagram is commutative:

$$\begin{array}{ccc}
 & & \mathbf{Z}[x_1, \dots, x_n] \\
 \varphi \nearrow & & \downarrow f \\
 S & & R \\
 \searrow \psi & &
 \end{array}$$

7.2. The Stone–Čech Compactification. For any Tychonoff space X , there is defined a certain compact Hausdorff space $\beta(X)$ which contains X as an everywhere dense subset; it is called the Stone–Čech Compactification of X . Let $\varphi : X \rightarrow \beta(X)$ denote the inclusion map. Then, we have the following characterization: For any compact Hausdorff space Y and any continuous map $\psi : X \rightarrow Y$, there exists a unique continuous map $f : \beta(X) \rightarrow Y$ such that the following diagram is commutative:

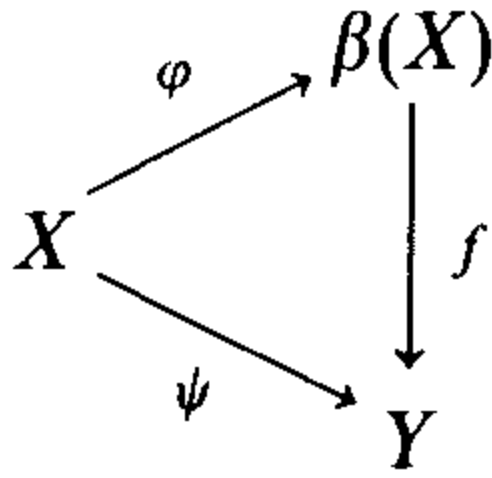

For a more complete discussion see J. L. Kelley, *General Topology*. Princeton, N.J.: Van Nostrand, 1955. pp. 152–153.

For a precise, axiomatic treatment of universal mapping problems and further examples, see references [5, 7].

NOTES

Definition of free groups, free products, etc.

The concepts of free abelian group, free group, free product of groups, etc., are rather old. The main difference between a modern treatment of the subject and one of the older treatments is the method of defining these algebraic objects. Formerly, they were defined in terms of what are now considered some of their characteristic properties. For example, a free group on set S was defined to be the collection of all equivalence classes of “words” formed from the elements of S . From a strictly logical point of view, there can be no objection to this procedure. However, from a conceptual point of view, it has the disadvantage that the definition of each type of free object requires new insight and ingenuity, and may be a difficult problem. The idea of defining free objects as solutions to universal mapping problems, which gradually evolved during the time of World War II and immediately thereafter, seems to be one of the important unifying ideas in modern mathematics.

The elegant proof given in the text for the existence of free products of groups (Theorem 4.2), which is simpler than the older proofs, is due to B.L. Van der Waerden (*Am. J. Math.* **70** (1948), 527–528). In a more recent paper (*Proc. Kon. Ned. Akad. Wet.* (series A) **69** (1966), 78–83), Van der Waerden has pointed out how the basic idea of the procedure used for the proof of Theorem 4.2 is applicable to prove the existence of solutions to universal mapping problems in many other algebraic situations.

Different levels of abstraction in mathematics

The first time the student encounters the material in this chapter, it may seem rather foreign to him. The probable reason is that it is on a higher level of abstraction than any of his previous studies in mathematics. To make this point clearer, we shall try to describe briefly the different levels of abstraction that seem to occur naturally in mathematics.

The lowest level of abstraction is the level of most high school and begin-

ning undergraduate mathematics courses. This level is characterized by a concern with a few very explicit mathematical objects, e.g., the integers, rational numbers, real numbers, the complex numbers, the Euclidean plane, etc. The next level of abstraction occurs when certain properties common to several different concrete mathematical objects are isolated and studied for their own sake. This leads to the study of such abstract and general mathematical systems as groups, rings, fields, vector spaces, topological spaces, etc. Ordinarily the mathematics student makes the transition to this level of abstraction some time in this undergraduate career.

The material of this chapter provides an introduction to the next higher level of abstraction. As was pointed out in Example 4.1, the weak direct product of two abelian groups, G_1 and G_2 , and their free product $G_1 * G_2$, are quite different types of groups. Yet there is a strong analogy between the weak direct product of abelian groups and the free product of arbitrary groups. To perceive this analogy, it is necessary to consider the category of all abelian groups and the category of all (i.e., not necessarily abelian) groups, respectively. This is characteristic of this next level of abstraction: the simultaneous consideration of all mathematical systems (e.g., groups, rings, or topological spaces) of a certain kind, and the study of the properties of such a collection of mathematical systems.

The history of mathematics in the last two hundred years or so has been characterized by the considerations of mathematical systems on ever higher levels of abstraction. Presumably this trend will continue in the future. It should be emphasized strongly, however, that this movement is not a case of abstraction for the sake of abstraction itself. Rather, it has been forced on mathematicians for various reasons, such as bringing out the analogies between seemingly quite different phenomena.

Presentations of groups by generators and relations

Let us emphasize that the specification of a group by means of generators and relations is very unsatisfactory in many respects, because some of the most natural problems that arise in connection with group presentations are very difficult or impossible. For a further discussion of this point, see the texts by Kurosh [1, Chap. X] or Rotman [4, Chap. 12].

That part of group theory which is concerned with groups presented by generators and relations is called "Combinatorial Group Theory." The standard introductory text on this subject is Magnus, Karrass, and Solitar [3]. A more advanced treatise is Lyndon and Schupp [2].

References

Group theory

1. A. G. Kurosh, *The Theory of Groups*, Trans. and ed. by K. A. Hirsch, 2 vols., Chelsea, New York, 1955–56, Chapters IX and X.

2. R. C. Lyndon and P. E. Schupp, *Combinatorial Group Theory*, Springer-Verlag, New York, 1977.
3. W. Magnus, A. Karrass, and D. Solitar, *Combinatorial Group Theory* (2nd revised ed.), Dover, New York, 1976.
4. J. J. Rotman, *The Theory of Groups*, Allyn and Bacon, Boston, 1965, Chapter 11.

Universal mapping problems

5. N. Bourbaki, *Théorie des Ensembles*, Hermann et Cie., Paris, 1970, Chapter IV, Section 3.
6. C. Chevalley, *Fundamental Concepts of Algebra*, Academic Press, New York, 1956.
7. P. Samuel, On Universal Mappings and Free Topological Groups. *Bull. Am. Math. Soc.* **54** (1948), 591–598.

CHAPTER IV

Seifert and Van Kampen Theorem on the Fundamental Group of the Union of Two Spaces. Applications

§1. Introduction

So far we have actually determined the structure of the fundamental group of only a very few spaces (e.g., contractible spaces, the circle). To be able to apply the fundamental group to a wider variety of problems, we must know methods for determining its structure for more spaces. In this chapter, we shall develop rather general means for doing this.

Assume that we wish to determine the fundamental group of an arcwise-connected space X , which is the union of two subspaces U and V , each of which is arcwise connected, and whose fundamental group is known. Choose a base point $x_0 \in U \cap V$; it seems plausible to expect that there should be relations between the groups $\pi(U, x_0)$, $\pi(V, x_0)$, and $\pi(X, x_0)$. The main theorem of this chapter (discovered independently by H. Seifert and E. Van Kampen) asserts that, if U and V are both open sets, and it is assumed that their intersection $U \cap V$ is also arcwise connected, then $\pi(X, x_0)$ is *completely* determined by the following diagram of groups and homomorphisms:

$$\begin{array}{ccc} & & \pi(U) \\ & \nearrow^{\varphi_1} & \\ \pi(U \cap V) & & \\ & \searrow_{\varphi_2} & \\ & & \pi(V) \end{array} \quad (4.1.1)$$

Here φ_1 and φ_2 are induced by inclusion maps. The way in which $\pi(X, x_0)$ is determined by this diagram can be roughly described as follows. The above diagram can be completed by forming the following commutative diagram:

$$\begin{array}{ccc}
 & \pi(U) & \\
 \varphi_1 \nearrow & & \searrow \psi_1 \\
 \pi(U \cap V) & \longrightarrow & \pi(X). \\
 \varphi_2 \searrow & & \nearrow \psi_1 \\
 & \pi(V) &
 \end{array} \tag{4.1.2}$$

Here all arrows denote homomorphisms induced by inclusion maps, and the base point x_0 is systematically omitted. Then, the Seifert–Van Kampen theorem asserts that $\pi(X)$ is the *freest possible* group we can use to complete diagram (4.1.1) to a commutative diagram like (4.1.2). As usual, the phrase “freest possible” is made precise by the consideration of a certain universal mapping problem.

Actually, we shall state and prove a more general version of the theorem, in that we allow X to be the union of any number of arcwise-connected open subsets rather than just two. This more general version is no more difficult to prove, and in some situations it is the only applicable version.

After proving the Seifert–Van Kampen theorem, we state several corollaries and then use these corollaries to determine the structure of the fundamental groups of the various compact surfaces and certain other spaces. In the final section of this chapter we show how these methods can be applied to distinguish between certain knots.

§2. Statement and Proof of the Theorem of Seifert and Van Kampen

First, we give a precise statement of the theorem. Assume that U and V are arcwise-connected open subsets of X such that $X = U \cup V$ and $U \cap V$ is nonempty and arcwise connected. Choose a base point $x_0 \in U \cap V$ for all fundamental groups under consideration.

Theorem 2.1. *Let H be any group, and $\rho_1, \rho_2,$ and ρ_3 any three homomorphisms such that the following diagram is commutative:*

$$\begin{array}{ccc}
 & \pi(U) & \\
 \varphi_1 \nearrow & & \searrow \rho_1 \\
 \pi(U \cap V) & \xrightarrow{\rho_3} & H \\
 \varphi_2 \searrow & & \nearrow \rho_2 \\
 & \pi(V) &
 \end{array}$$

Then, there exists a unique homomorphism $\sigma : \pi(X) \rightarrow H$ such that the following three diagrams are commutative:

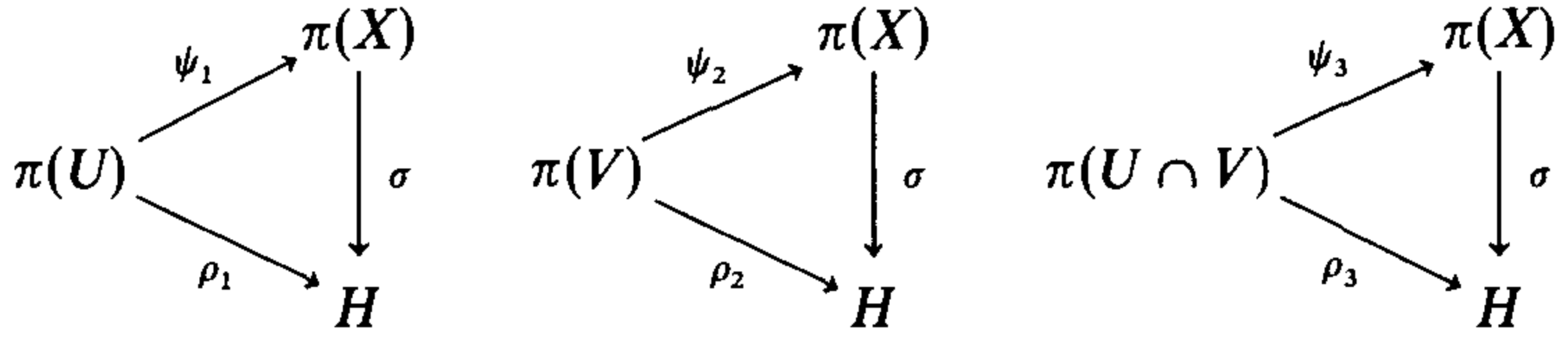

(Here the homomorphisms φ_i and ψ_i , $i = 1, 2, 3$, are induced by inclusion maps.)

By the methods used in Chapter III, we can prove that the group $\pi(X)$ is characterized up to isomorphism by this theorem. We leave the precise statement and proof of this fact to the reader.

We shall next state the more general version of the Seifert–Van Kampen theorem. The generalization consists in allowing a covering of the space X by any number of open sets instead of just by two open sets as in Theorem 2.1. Of course, the open sets must all be arcwise connected, and the intersection of any finite number of them must be arcwise connected and contain the base point. To be precise, we assume the following hypotheses:

- (a) X is an arcwise-connected topological space and $x_0 \in X$.
- (b) $\{U_\lambda : \lambda \in \Lambda\}$ is a covering of X of arcwise-connected open sets such that for all $\lambda \in \Lambda$, $x_0 \in U_\lambda$.
- (c) For any two indices $\lambda_1, \lambda_2 \in \Lambda$ there exists an index $\lambda \in \Lambda$ such that $U_{\lambda_1} \cap U_{\lambda_2} = U_\lambda$ (we express this fact by saying that the family of sets $\{U_\lambda\}$ is “closed under finite intersections”).

We now consider the fundamental groups of these various sets with base point x_0 . For brevity, we omit the base point from the notation.

If $U_\lambda \subset U_\mu$, then the notation

$$\varphi_{\lambda\mu} : \pi(U_\lambda) \rightarrow \pi(U_\mu)$$

denotes the homomorphism induced by the inclusion map. Similarly, for any index λ ,

$$\psi_\lambda : \pi(U_\lambda) \rightarrow \pi(X)$$

is induced by the inclusion map $U_\lambda \rightarrow X$. Note that, if $U_\lambda \subset U_\mu$, the following diagram is commutative:

$$\begin{array}{ccc} \pi(U_\lambda) & & \\ \downarrow \varphi_{\lambda\mu} & \searrow \psi_\lambda & \\ \pi(U_\mu) & & \pi(X) \\ & \nearrow \psi_\mu & \end{array}$$

Theorem 2.2. *Under the above hypotheses the group $\pi(X)$ satisfies the following universal mapping condition: Let H be any group and let $\rho_\lambda : \pi(U_\lambda) \rightarrow H$ be any collection of homomorphisms defined for all $\lambda \in \Lambda$ such that if $U_\lambda \subset U_\mu$ the*

following diagram is commutative:

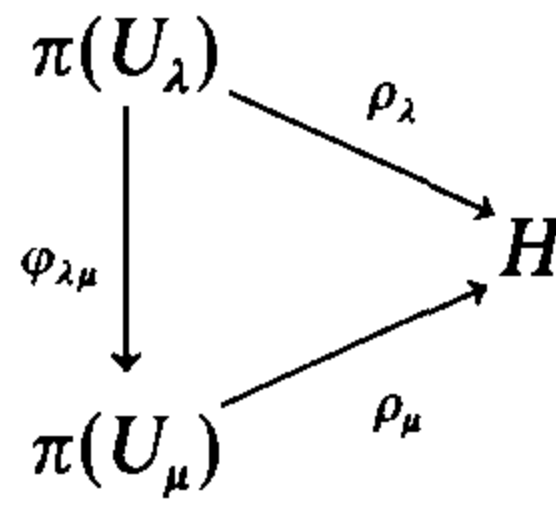

Then, there exists a unique homomorphism $\sigma : \pi(X) \rightarrow H$ such that for any $\lambda \in \Lambda$ the following diagram is commutative:

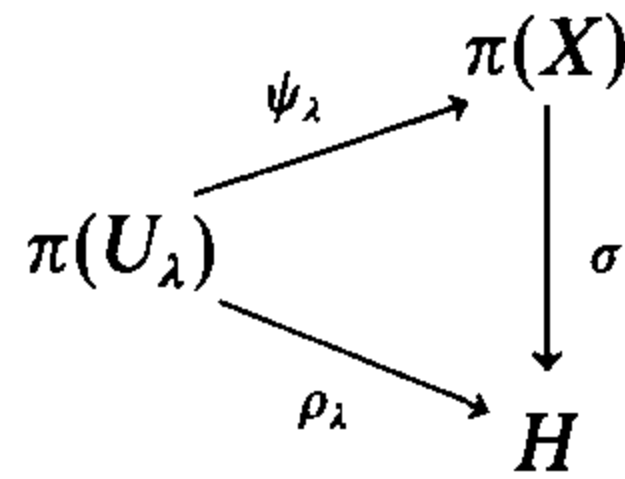

Moreover, this universal mapping condition characterizes $\pi(X)$ up to a unique isomorphism.

The proof of the last sentence of the theorem is a routine matter which may be left to the reader. We shall now give the proof of the rest of this theorem. Applications of this theorem are given in §3–§6.

Lemma. 2.3. *The group $\pi(X)$ is generated by the union of the images $\psi_\lambda[\pi(U_\lambda)]$, $\lambda \in \Lambda$.*

PROOF. Let $\alpha \in \pi(X)$; choose a closed path $f : I \rightarrow X$ representing α . Choose an integer n so large that $1/n$ is less than the Lebesgue number of the open covering $\{f^{-1}(U_\lambda) : \lambda \in \Lambda\}$ of the compact metric space I . Subdivide the interval I into the closed subintervals $J_i = [i/n, (i+1)/n]$, $0 \leq i \leq n-1$. For each subinterval J_i , choose an index $\lambda_i \in \Lambda$ such that $f(J_i) \subset U_{\lambda_i}$. Choose a path g_i in $U_{\lambda_{i-1}} \cap U_{\lambda_i}$ joining the point x_0 to the point $f(i/n)$, $1 \leq i \leq n-1$. Let $f_i : I \rightarrow X$ denote the path represented by the composite function

$$I \xrightarrow{h_i} J_i \xrightarrow{f|_{J_i}} X,$$

where h_i is the unique orientation-preserving linear homeomorphism. Then $f_0 \cdot g_1^{-1}, g_1 \cdot f_1 \cdot g_2^{-1}, g_2 \cdot f_2 \cdot g_3^{-1}, \dots, g_{n-2} \cdot f_{n-2} \cdot g_{n-1}^{-1}, g_{n-1} \cdot f_{n-1}$ are closed paths, each contained in a single open set U_λ , and their product in the order given is equivalent to f . Hence, we can write

$$\alpha = \alpha_0 \cdot \alpha_1 \cdot \alpha_2 \cdot \dots \cdot \alpha_{n-1},$$

where

$$\alpha_i \in \psi_{\lambda_i}[\pi(U_{\lambda_i})], \quad 0 \leq i \leq n-1.$$

This completes the proof of the lemma.

Remark: The hypotheses could be slightly weakened for the purposes of this lemma. Actually it is only required that $\{U_\lambda\}$ be an open covering by arcwise-connected subsets of X such that the intersection of any two sets be arcwise connected. It does not matter whether or not the intersection of three sets is arcwise connected.

PROOF OF THEOREM 2.2. Let H be any group and let $\rho_\lambda : \pi(U_\lambda) \rightarrow H$, $\lambda \in \Lambda$, be a set of homomorphisms satisfying the hypotheses of the theorem. We must demonstrate the existence of a unique homomorphism $\sigma : \pi(X) \rightarrow H$ such that the following diagram is commutative for any $\lambda \in \Lambda$:

$$\begin{array}{ccc} & & \pi(X) \\ & \nearrow \psi_\lambda & \downarrow \sigma \\ \pi(U_\lambda) & & H \\ & \searrow \rho_\lambda & \end{array}$$

From the lemma just proved, it is clear that such a homomorphism σ , if it exists, must be unique, and must be defined according to the following rule. Let $\alpha \in \pi(X)$. Then, by Lemma 2.3, we have

$$\alpha = \psi_{\lambda_1}(\alpha_1) \cdot \psi_{\lambda_2}(\alpha_2) \cdot \dots \cdot \psi_{\lambda_n}(\alpha_n), \quad (4.2.1)$$

where $\alpha_i \in \pi(U_{\lambda_i})$, $i = 1, 2, \dots, n$. Hence, if the homomorphism σ exists, we must have

$$\sigma(\alpha) = \rho_{\lambda_1}(\alpha_1) \cdot \rho_{\lambda_2}(\alpha_2) \cdot \dots \cdot \rho_{\lambda_n}(\alpha_n). \quad (4.2.2)$$

Our strategy will be to take equation (4.2.2) as a definition of σ . To justify this definition, we must show that it is independent of the choice of the representation of α in the form (4.2.1). Clearly, if it is independent of the form of the representation of α , then it is a homomorphism, and the desired commutativity relations must hold.

To prove that σ is independent of the representation of α in the form (4.2.1), it suffices to prove the following lemma:

Lemma 2.4. Let $\beta_i \in \pi(U_{\lambda_i})$, $i = 1, \dots, q$ be such that

$$\psi_{\lambda_1}(\beta_1) \cdot \psi_{\lambda_2}(\beta_2) \cdot \dots \cdot \psi_{\lambda_q}(\beta_q) = 1.$$

Then, the product

$$\rho_{\lambda_1}(\beta_1) \rho_{\lambda_2}(\beta_2) \cdots \rho_{\lambda_q}(\beta_q) = 1.$$

Although the proof of this lemma does not require any new methods, it is rather long, tedious, and complicated. In order not to interrupt the exposition, the proof has been relegated to §7 at the end of this chapter.

§3. First Application of Theorem 2.1

Assume, as in the statement of Theorem 2.1, that X is the union of the open sets U and V and that U , V , and $U \cap V$ are all arcwise connected. Let φ_i and ψ_i have the meaning assigned to them in §2.

Theorem 3.1. *If $U \cap V$ is simply connected, then $\pi(X)$ is the free product of the groups $\pi(U)$ and $\pi(V)$ with respect to the homomorphisms $\psi_1 : \pi(U) \rightarrow \pi(X)$ and $\psi_2 : \pi(V) \rightarrow \pi(X)$.*

PROOF. This is a direct corollary of Theorem 2.1. If $\pi(U \cap V) = \{1\}$, then the diagram

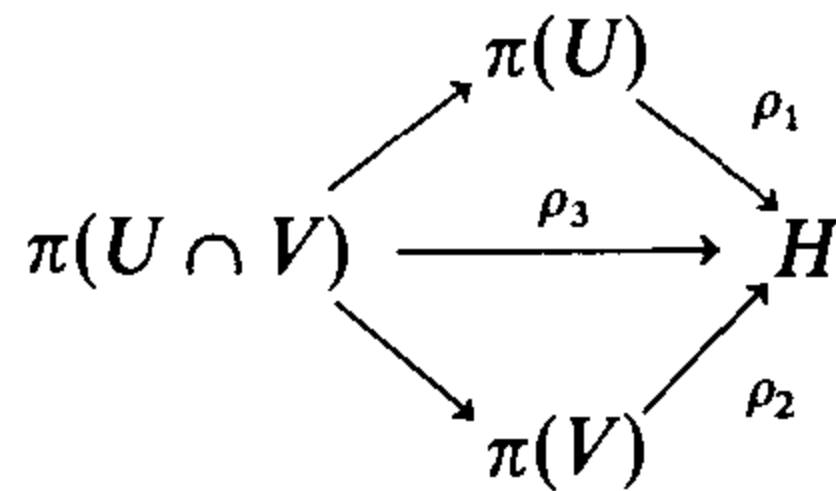

will be commutative for any choice of ρ_1 and ρ_2 ; hence, these two homomorphisms are completely arbitrary, whereas ρ_3 is uniquely determined. Similarly, the diagram

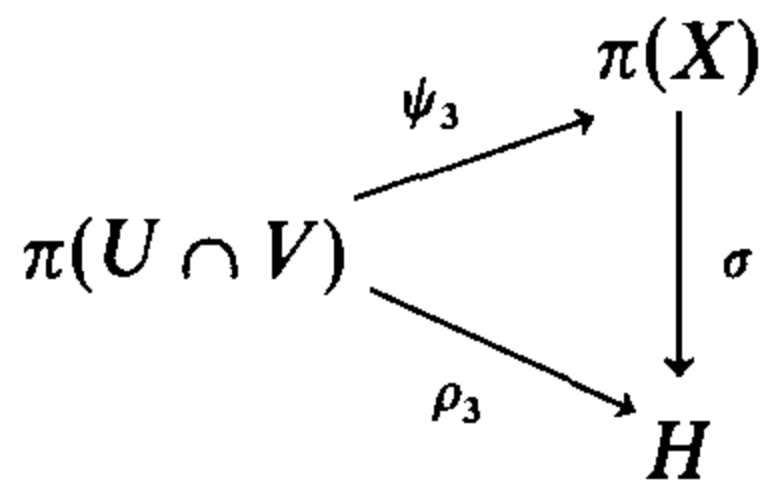

will be commutative for any choice of σ ; requiring it to be commutative imposes no condition on σ . The remaining two conditions on σ in Theorem 2.1 are exactly those which occur in the definition of the free product of two groups. Q.E.D.

We now give some examples where this theorem is applicable. These examples will, in turn, be used later to study other examples.

Examples

3.1. Let X be a space such that $X = A \cup B$, $A \cap B = \{x_0\}$, and A and B are each homeomorphic to a circle S^1 (see Figure 4.1). X may be visualized as a curve shaped like a figure “8.”

If A and B were open subsets of X , we could apply Theorem 3.1 with $U = A$ and $V = B$ to determine the structure of $\pi(X)$. Unfortunately, A and B are not open.

However, a slight modification of this strategy will work. Choose points $a \in A$ and $b \in B$ such that $a \neq x_0$ and $b \neq x_0$. Let $U = X - \{b\}$, and

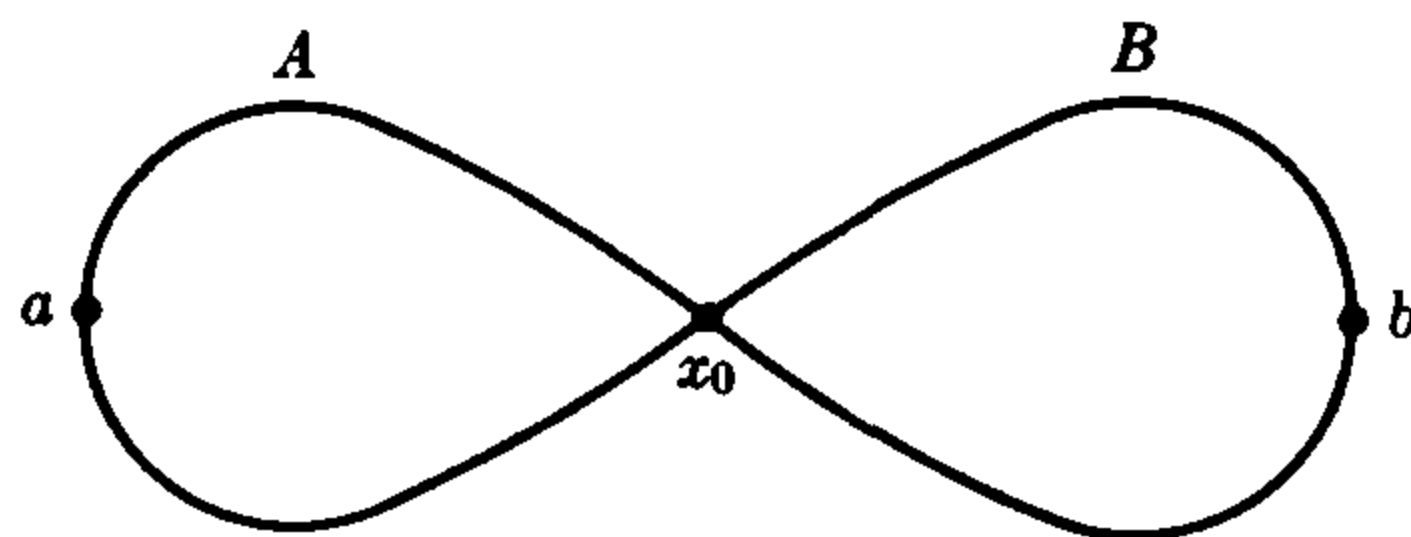

FIGURE 4.1. Example 3.1, a figure “8” curve.

let $V = X - \{a\}$. U and V are each homeomorphic to a circle with two “whiskers.” Then, it is clear that A and B are deformation retracts of U and V , respectively, and that $U \cap V = X - \{a, b\}$ is contractible, hence, simply connected. Thus, we conclude that $\pi(X)$ is the free product of the groups $\pi(U)$ and $\pi(V)$ or, equivalently, the free product of $\pi(A)$ and $\pi(B)$ [because $\pi(A) \approx \pi(U)$ and $\pi(B) \approx \pi(V)$]. Because A and B are circles, $\pi(A)$ and $\pi(B)$ are infinite cyclic groups. Therefore, $\pi(X)$ is the free product of two infinite cyclic groups; by Proposition III.5.2, $\pi(X)$ is a free group on two generators. We can take as generators closed path classes α and β based at x_0 , which go once around A and B , respectively.

3.2. Let E^2 be the closed unit disc in the plane, let a and b be distinct interior points of E^2 , and let $Y = E^2 - \{a, b\}$. It is easily seen that we can find a subset $X \subset Y$, such that X is the union of two circles with a single point in common, as in Example 3.1, and X is a deformation retract of Y (see Figure 4.2). Therefore, $\pi(Y) \approx \pi(X)$, and $\pi(Y)$ is a free group on two generators. We can take as generators path classes α and β based at x_0 which go once around the “holes” a and b .

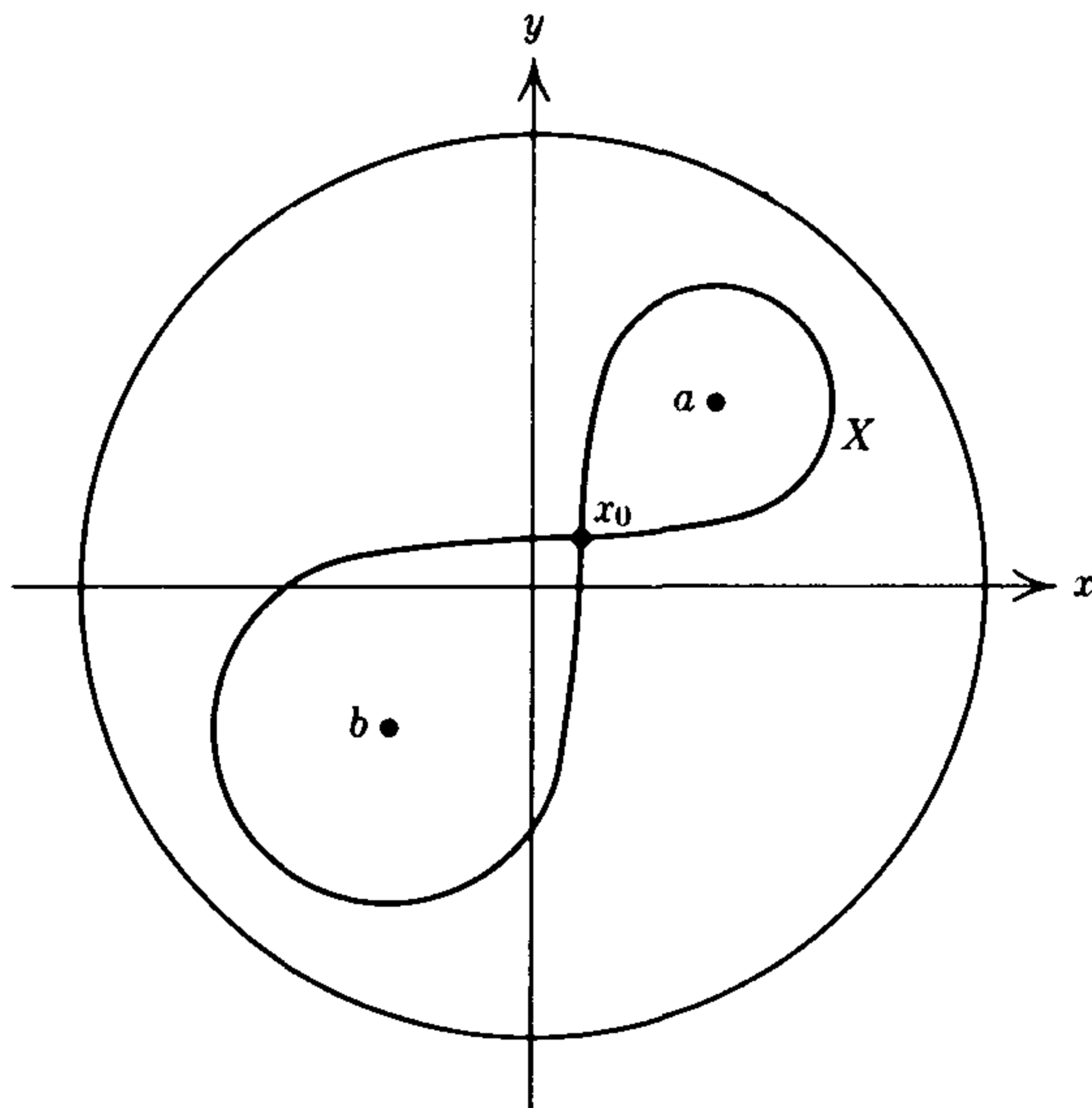

FIGURE 4.2. Example 3.2, a disc with two holes.

There is an experimental physical verification of this result that appeals to one's geometric intuition. Take a piece of plywood or some other strong, light material in the shape of a circular disc, and at the points a and b attach vertical pegs several inches long. Fasten both ends of a piece of string a few feet long to the plywood at the point x_0 with a thumbtack. Any element $\neq 1$ of the fundamental group of Y can be represented uniquely as a "reduced word" in α and β ; and for any such reduced word, we can choose a representative path in Y and then lay out the string on the board to represent this path. We can then test experimentally whether or not this path is equivalent to the constant path by moving the string about on the board. Of course, it is not permissible to lift the string over the pegs while doing this.

3.3. The same argument applies if Y is an open disc minus two points, or the entire plane minus two points, or a sphere minus three points. It also applies if, instead of removing isolated points from a disc, we remove small circular discs, either open or closed.

3.4. Let X be the union of n circles with a single point in common, $n > 2$; i.e.,

$$X = A_1 \cup A_2 \cup \cdots \cup A_n,$$

where each A_i is homeomorphic to S^1 , and, if $i \neq j$, $A_i \cap A_j = \{x_0\}$. The space X can be pictured as an " n -leafed rose" in the plane (see Figure 4.3 for the case where $n = 4$). We will prove by induction on n that $\pi(X)$ is a free group on n generators, $\alpha_1, \alpha_2, \dots, \alpha_n$, where α_i is represented by a path that goes around the circle A_i once. We have already proved this in the case where $n = 2$. To make this induction, we apply Theorem 3.1 as follows. Choose a point $a_i \in A_i$ such that $a_i \neq x_0$. Let

$$U = X - \{a_n\},$$

$$V = X - \{a_1, a_2, \dots, a_{n-1}\}.$$

Then, U and V are open sets, $A_1 \cup \cdots \cup A_{n-1}$ is a deformation retract of U , A_n is a deformation retract of V , and $U \cap V$ is contractible. Thus, using Theorem 3.1, we can conclude $\pi(X, x_0)$ is the free product of $\pi(U)$ and $\pi(V)$ or equivalently, of $\pi(A_1 \cup \cdots \cup A_{n-1})$ and $\pi(A_n)$. Proposition III.5.2 can now be applied to complete the proof of the inductive step.

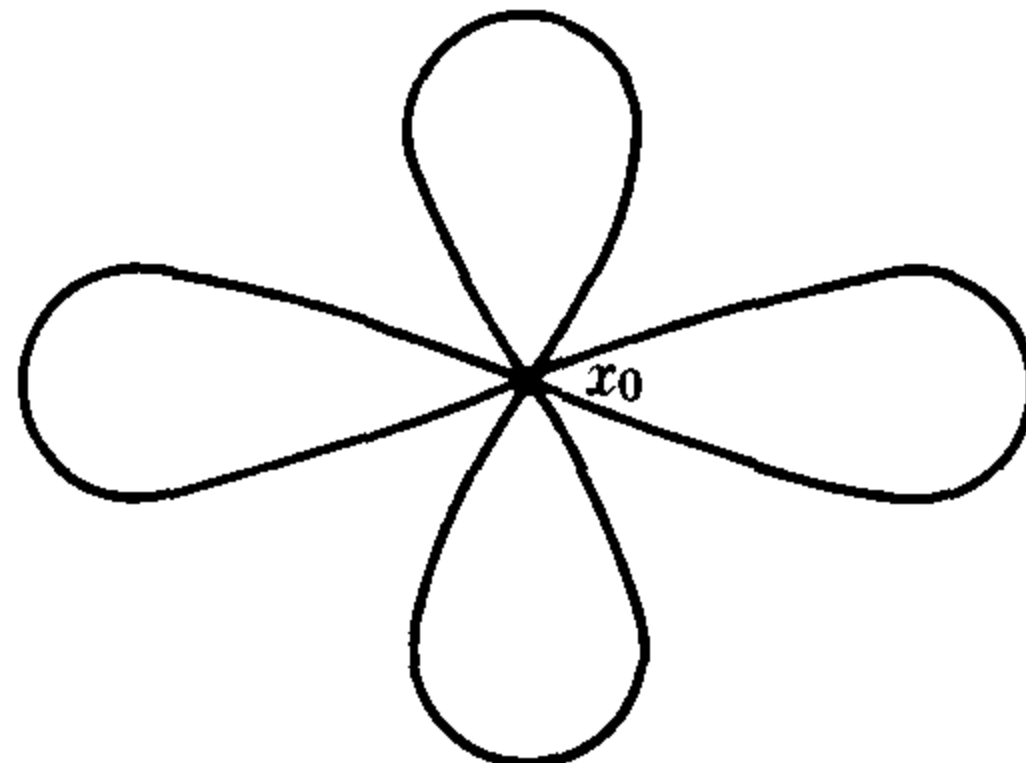

FIGURE 4.3. Example 3.4 for the case $n = 4$.

3.5. We can use the result just proved to discuss the following example: Let Y be a space obtained by removing n points from a disc (open or closed) or from the entire plane. By the same type of argument as that used in Example 3.2, we conclude $\pi(Y)$ is a free group on n generators, $\alpha_1, \alpha_2, \dots, \alpha_n$. Roughly speaking, α_i is represented by a closed path which goes around the i th hole once.

We leave it to the reader to discuss a physical model illustrating that $\pi(Y)$ is a free group on n generators, as was done for Example 3.2.

EXERCISES

3.1. Prove the following generalization of Theorem 3.1. Let $\{W\} \cup \{V_i : i \in I\}$ be a covering of X by open arcwise-connected sets having the following properties: (a) W is a *proper* subset of V_i for all $i \in I$. (b) For any two distinct indices $i, j \in I$, $V_i \cap V_j = W$. (c) W is simply connected. (d) $x_0 \in W$. Using Theorem 2.2, prove that $\pi(X, x_0)$ is the free product of the groups $\pi(V_i, x_0)$ [with respect to the homomorphisms $\psi_i : \pi(V_i) \rightarrow \pi(X)$ induced by inclusion maps].

3.2. Let

$$X = \bigcup_{i \in I} A_i,$$

where each A_i is homeomorphic to S^1 , be such that, for any two distinct indices $i, j \in I$, $A_i \cap A_j = \{x_0\}$, and the topology on X satisfies the Hausdorff separation axiom and the following condition: A subset B of X is closed (open) if and only if $B \cap A_i$ is a closed (open) subset of A_i for all $i \in I$. For each index i , let α_i be a generator of the infinite cyclic group $\pi(A_i, x_0)$. Use the result of Exercise 3.1 to prove that $\pi(X, x_0)$ is a free group on the set $\{\alpha_i : i \in I\}$.

3.3. Give an example of a compact Hausdorff space

$$X = \bigcup_{i=1}^{\infty} A_i,$$

where each A_i is homeomorphic to S^1 , $A_i \cap A_j = \{x_0\}$ for $i \neq j$, and yet X does not satisfy the condition of the previous exercise. (SUGGESTION: there exists a subset of the Euclidean plane having the required properties.) Is $\pi(X, x_0)$ a free group on the set $\{\alpha_i\}$, as in Exercise 3.2?

3.4. Let Y be the complement of the following subset of the plane \mathbf{R}^2 :

$$\{(x, 0) \in \mathbf{R}^2 : x \text{ is an integer}\}.$$

Prove that $\pi(Y)$ is a free group on a countable set of generators.

3.5. Let X be a Hausdorff space such that $X = A \cup B$, where A and B are each homeomorphic to a torus, and $A \cap B = \{x_0\}$. What is the structure of $\pi(X, x_0)$?

3.6. Let M_1 and M_2 be disjoint, connected n -manifolds. Prove that the following method of constructing the connected sum $M_1 \# M_2$ is equivalent to the definition given in §I.4 in the case where $n = 2$. Choose points $m_i \in M_i$, and open neighborhoods U_i of m_i such that there exist homeomorphisms h_i of U_i onto \mathbf{R}^n with

$h_i(m_i) = 0, i = 1, 2$. Define $M_1 \# M_2$ to be the quotient space of $(M_1 - \{m_1\}) \cup (M_2 - \{m_2\})$ obtained by identifying points $x_1 \in U_1 - \{m_1\}$ and $x_2 \in U_2 - \{m_2\}$ if and only if

$$h_1(x_1) = \frac{h_2(x_2)}{|h_2(x_2)|^2}.$$

3.7. If M_1 and M_2 are connected n -manifolds, $n > 2$, prove that $\pi(M_1 \# M_2)$ is the free product of $\pi(M_1)$ and $\pi(M_2)$.

§4. Second Application of Theorem 2.1

Once again we assume the hypotheses and notation of Theorem 2.1: U, V , and $U \cap V$ are arcwise-connected open subsets of $X, X = U \cup V$, and $x_0 \in U \cap V$.

Theorem 4.1. *Assume that V is simply connected. Then, $\psi_1 : \pi(U) \rightarrow \pi(X)$ is an epimorphism, and its kernel is the smallest normal subgroup of $\pi(U)$ containing the image $\varphi_1[\pi(U \cap V)]$.*

Note that this theorem completely specifies the structure of $\pi(X)$: It is isomorphic to the quotient group of $\pi(U)$ modulo the stated normal subgroup.

PROOF. Consider the following commutative diagram:

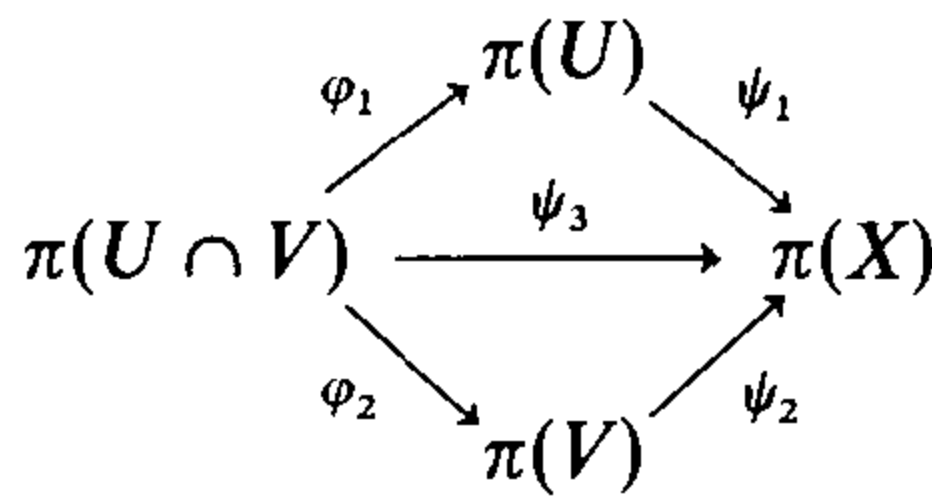

Because $\pi(V) = \{1\}$, it readily follows that ψ_3 is a trivial homomorphism and that image φ_1 is contained in kernel ψ_1 . It is also clear that ψ_1 is an epimorphism; this follows from Lemma 2.3, or we could prove it directly from Theorem 2.1.

Thus, the only thing remaining is to prove that the kernel of ψ_1 is the *smallest* normal subgroup of $\pi(U)$ containing image φ_1 (conceivably, it could be a larger normal subgroup containing image φ_1). For this purpose, take $H = \pi(U)/N$, where N is the smallest normal subgroup of $\pi(U)$ containing image φ_1 , and let $\rho_1 : \pi(U) \rightarrow H$ be the natural map of $\pi(U)$ onto its quotient group. Let $\rho_2 : \pi(V) \rightarrow H$ and $\rho_3 : \pi(U \cap V) \rightarrow H$ be trivial homomorphisms. Then, the hypotheses of Theorem 2.1 are satisfied. Hence, we conclude that there exists a homomorphism $\sigma : \pi(X) \rightarrow H$ such that the following diagram is commutative:

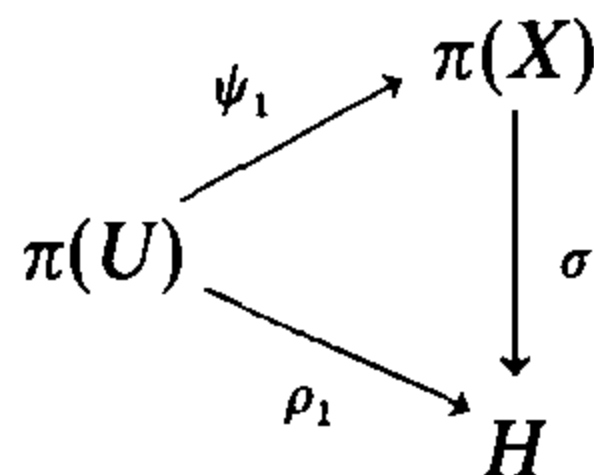

From this, it follows that

$$\text{kernel } \psi_1 \subset \text{kernel } \rho_1 = N.$$

Because we already know that

$$N \subset \text{kernel } \psi_1,$$

we can conclude that

$$\text{kernel } \psi_1 = N$$

as required.

Q.E.D.

In the next section we combine this theorem with our preceding results to determine the structure of the fundamental groups of the various compact, connected 2-manifolds.

EXERCISES

4.1. Assuming the hypotheses and using the notation of Theorem 2.1, prove the following assertions:

- (a) If φ_2 is an isomorphism onto, then so is ψ_1 .
- (b) If both φ_1 and φ_2 are epimorphisms, then ψ_3 is also an epimorphism, and its kernel is the smallest normal subgroup of $\pi(U \cap V)$ which contains both the kernel of φ_1 and the kernel of φ_2 .
- (c) If $\pi(U \cap V)$ is a cyclic group with generator α , then $\pi(X)$ is isomorphic to the quotient group of the free product of $\pi(U)$ and $\pi(V)$ by the least normal subgroup containing $(\varphi_1 \alpha)(\varphi_2 \alpha)^{-1}$.
- (d) $\pi(X)$ is isomorphic to the quotient group of the free product $\pi(U) * \pi(V)$ by the smallest normal subgroup containing

$$\{(\varphi_1 \alpha)(\varphi_2 \alpha)^{-1} : \alpha \in \pi(U \cap V)\}.$$

- (e) Assume that you are given presentations for the groups $\pi(U)$ and $\pi(V)$, also a set of generators for $\pi(U \cap V)$. Show how to obtain a presentation for $\pi(X)$ from this data and the knowledge of the homomorphism φ_1 and φ_2 . Prove that, if $\pi(U)$ and $\pi(V)$ have finite presentations, and $\pi(U \cap V)$ is finitely generated, then $\pi(X)$ has a finite presentation.
- (f) If φ_2 is an epimorphism, then so is ψ_1 . Describe the kernel of ψ_1 in this case.
- (g) If there exists a homomorphism $r: \pi(V) \rightarrow \pi(U \cap V)$ such that $r\varphi_2$ is the identity, then there exists a homomorphism $s: \pi(X) \rightarrow \pi(U)$ such that $s\psi_1$ is the identity, and $\varphi_1 r = s\psi_2$.

§5. Structure of the Fundamental Group of a Compact Surface

We shall show by examples how Theorem 4.1 can be used to determine the structure of the fundamental group of the various compact, connected 2-manifolds.

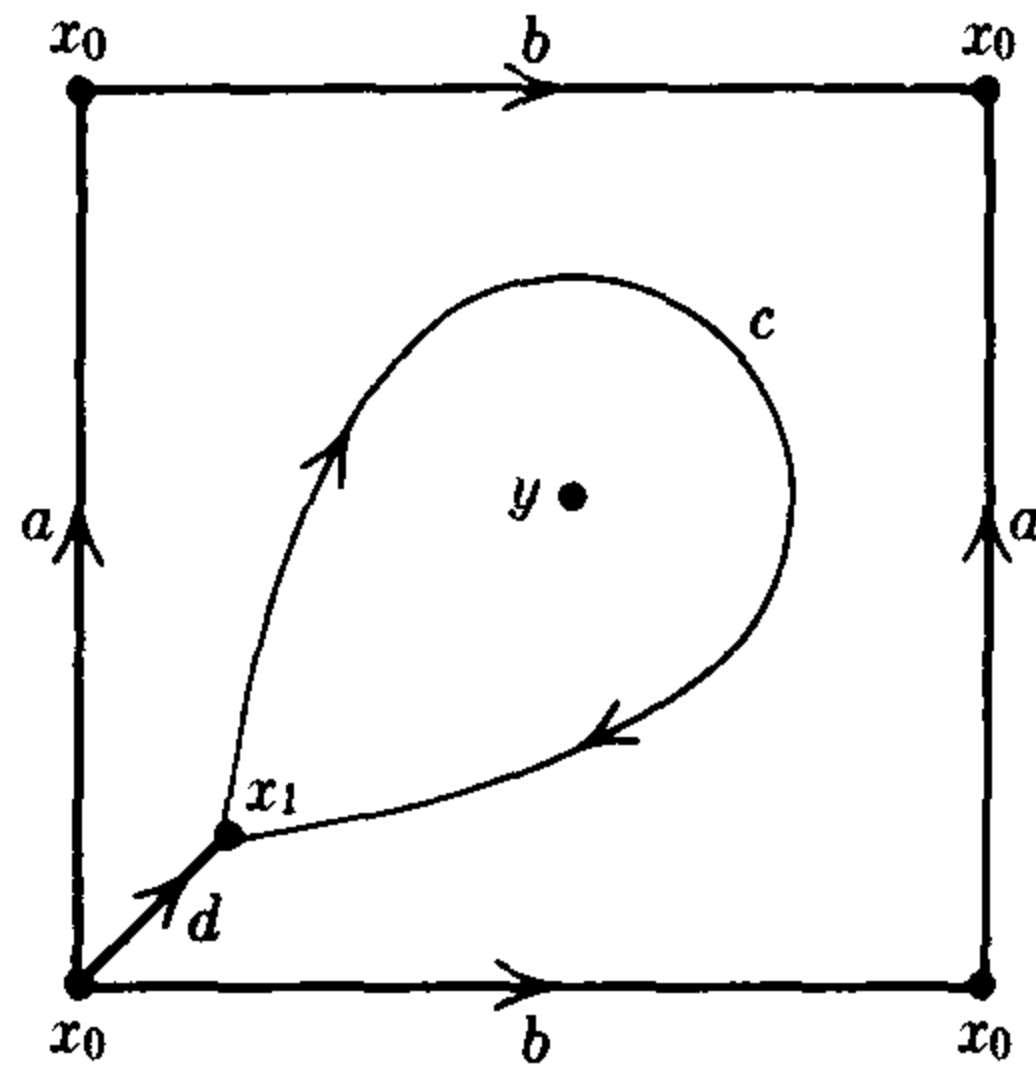

FIGURE 4.4. Determination of the fundamental group of a torus.

Examples

5.1. The torus, T . Because $T = S^1 \times S^1$, we already know by Theorem II.7.1 that

$$\pi(T) \approx \pi(S^1) \times \pi(S^1)$$

is the product of two infinite cyclic groups, i.e., a free abelian group on two generators. However, we shall derive this result from Theorem 4.1. This simple case serves as a good introduction to the rest of the examples.

Represent the torus as the space obtained by identifying the opposite faces of a square, as shown in Figure 4.4. Under the identification the sides a and b each become circles which intersect in the point x_0 . Let y be the center point of the square, and let $U = T - \{y\}$. Let V be the image of the interior of the square under the identification. Then, U and V are open subsets, U , V , and $U \cap V$ are arcwise connected, and V is simply connected (V is homeomorphic to an open disc). Thus, we can apply Theorem 4.1. We conclude that

$$\psi_1 : \pi(U, x_1) \rightarrow \pi(T, x_1)$$

is an epimorphism, and its kernel is the smallest normal subgroup containing the image of the homomorphism

$$\varphi_1 : \pi(U \cap V, x_1) \rightarrow \pi(U, x_1).$$

Because the boundary of a square is a deformation retract of the whole square minus a point, it is clear that the union of the two circles a and b is a deformation retract of U . Therefore, $\pi(U, x_1)$ is a free group on two generators. To be more precise, $\pi(U, x_0)$ is a free group on two generators α and β , where α and β are represented by the circles a and b , respectively. Hence, $\pi(U, x_1)$ is a free group on the two generators

$$\begin{aligned} \alpha' &= \delta^{-1}\alpha\delta, \\ \beta' &= \delta^{-1}\beta\delta, \end{aligned}$$

where δ is the equivalence class of a path d from x_0 to x_1 (see Figure 4.4). It is also clear that $U \cap V$ has the homotopy type of a circle. Therefore,

$\pi(U \cap V, x_1)$ is an infinite cyclic group generated by γ , the equivalence class of a closed path c which circles around the point y once. It is also clear from Figure 4.4 that

$$\varphi_1(\gamma) = \alpha' \beta' \alpha'^{-1} \beta'^{-1}.$$

Hence, $\pi(T, x_1)$ is isomorphic to the free group on the generators α' and β' modulo the normal subgroup generated by the element $\alpha' \beta' \alpha'^{-1} \beta'^{-1}$. Changing to the base point x_0 , we see that $\pi(T, x_0)$ is isomorphic to the free group on the generators α and β modulo the normal subgroup generated by $\alpha \beta \alpha^{-1} \beta^{-1}$.

This means exactly that we have a presentation of the group $\pi(T)$ (see §III.6). In this case, we can readily determine the structure of $\pi(T)$ from this presentation. On the one hand, it follows that the generators α and β of $\pi(T)$ commute; from this it follows that $\pi(T)$ is a commutative group, and therefore the least normal subgroup of the free group on α and β containing $\alpha \beta \alpha^{-1} \beta^{-1}$ contains the commutator subgroup. On the other hand, it is obvious that this normal subgroup is contained in the commutator subgroup. Therefore, the two subgroups are equal. Hence, by Proposition III.5.3, $\pi(T)$ is a free abelian group on the generators α and β .

5.2. The real projective plane, P_2 . We shall prove that $\pi(P_2)$ is cyclic of order 2 by using Theorem 4.1. We consider P_2 the space obtained by identifying the opposite sides of a 2-sided polygon, as shown in Figure 4.5. Under the identification, the edge a becomes a circle. Let y be the center point of the polygon,

$$U = P_2 - \{y\},$$

$V =$ image of the interior of the polygon under the identifications.

Then, the conditions for the application of Theorem 4.1 hold. In this case the circle a is a deformation retract of U ; therefore, $\pi(U, x_0)$ is an infinite cyclic group generated by an element α represented by the closed path a . Also, $\pi(U, x_1)$ is an infinite cyclic group generated by $\alpha' = \delta^{-1} \alpha \delta$, where δ has the same meaning as in Example 5.1. Finally, $\pi(U \cap V, x_1)$ is an infinite cyclic

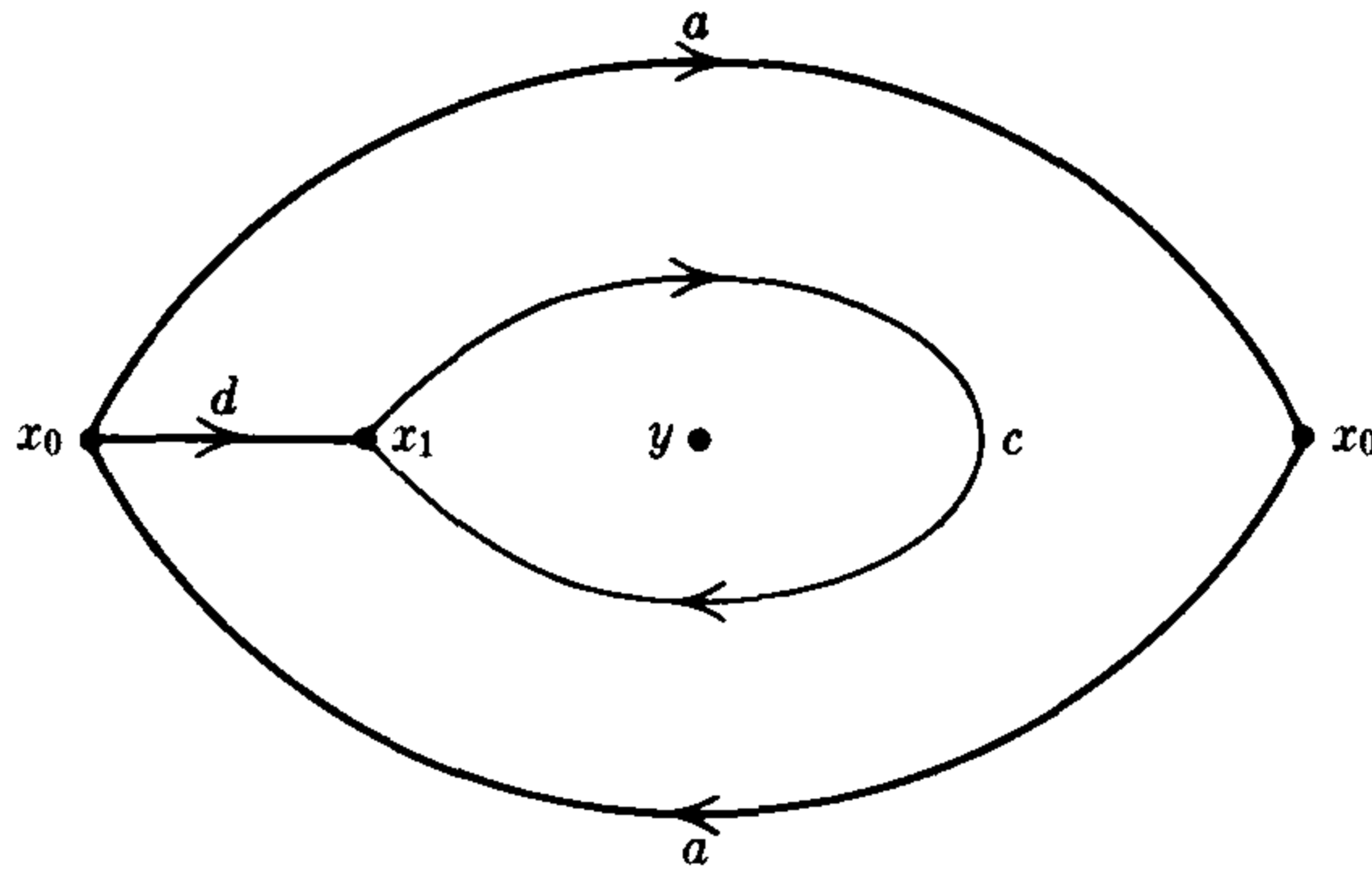

FIGURE 4.5. Determination of the fundamental group of a projective plane.

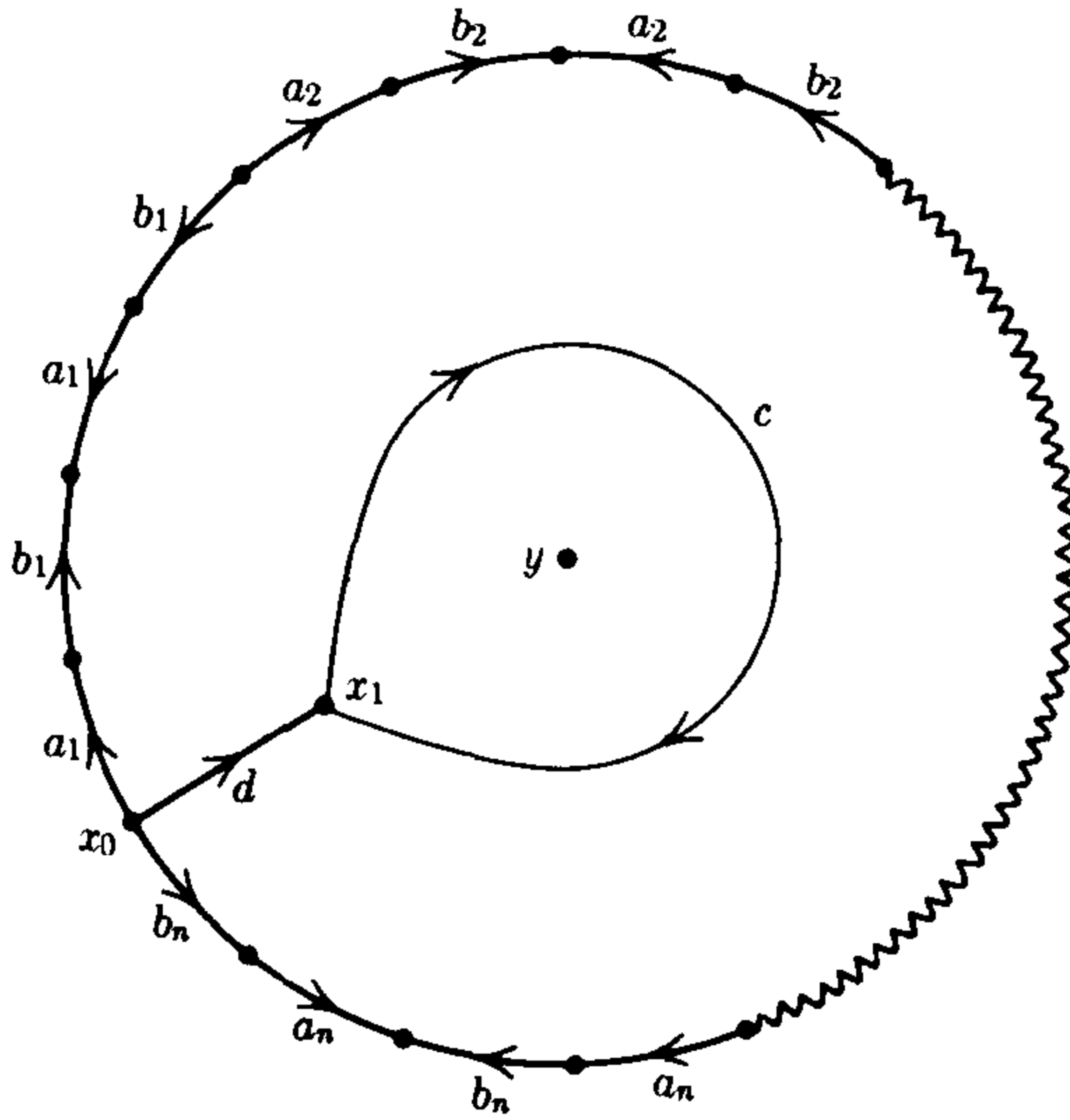

FIGURE 4.6. Determination of the fundamental group of an orientable surface of genus n .

group with generator γ represented by a closed path c which goes around the point y once. It is clear that

$$\varphi_1(\gamma) = \alpha'^2.$$

Therefore, $\pi(P_2, x_1)$ is the quotient of an infinite cyclic group generated by α' modulo the subgroup generated by α'^2 ; equivalently, $\pi(P_2, x_0)$ is the quotient of an infinite cyclic group generated by α modulo the subgroup generated by α^2 . Thus, $\pi(P_2)$ is a cyclic group of order 2.

5.3. The connected sum of n tori. Here the method is completely analogous to the two preceding examples, but the final result is new and more complicated. We can represent M , the sum of n tori, as a $4n$ -gon with the sides identified in pairs, as shown in Figure 4.6. Under the identification, the edges $a_1, b_1, a_2, b_2, \dots, a_n, b_n$ become circles on M , and any two of these circles intersect only in the base point x_0 . As before, let $U = M - \{y\}$, the complement of the center point y , and let V be the image of the interior of the polygon under the identification; V is an open disc in M . The union of the $2n$ circles $a_1, b_1, \dots, a_n, b_n$ is a deformation retract of U ; therefore, $\pi(U, x_0)$ is a free group on the $2n$ generators $\alpha_1, \beta_1, \alpha_2, \beta_2, \dots, \alpha_n, \beta_n$, where α_i is represented by the circle a_i , and β_i is represented by the circle b_i . As before, $\pi(U \cap V, x_1)$ is an infinite cyclic group with generator γ represented by the circle c , and

$$\varphi_1(\gamma) = \prod_{i=1}^n [\alpha'_i, \beta'_i],$$

where $[\alpha'_i, \beta'_i]$ denotes the commutator $\alpha'_i \beta'_i \alpha_i^{-1} \beta_i^{-1}$, and

$$\alpha'_i = \delta^{-1} \alpha_i \delta,$$

$$\beta'_i = \delta^{-1} \beta_i \delta.$$

As a result, $\pi(M, x_0)$ is the quotient of the free group on the generators $\alpha_1, \beta_1, \dots, \alpha_n, \beta_n$ modulo the normal subgroup generated by the element

$$\prod_{i=1}^n [\alpha_i, \beta_i];$$

i.e., $\pi(M, x_0)$ has a presentation consisting of the set of generators $\{\alpha_1, \beta_1, \dots, \alpha_n, \beta_n\}$ and the single relation

$$\prod_{i=1}^n [\alpha_i, \beta_i].$$

In the case where $n > 1$, there is no simple, invariant description of this group. It is readily seen however that if we “abelianize” $\pi(M, x_0)$ (i.e., if we take its quotient modulo its commutator subgroup), we obtain a free abelian group on $2n$ generators. This is a consequence of the single relation’s obviously being contained in the commutator subgroup of the free group on the generators $\alpha_1, \beta_1, \dots, \alpha_n, \beta_n$. From this it follows that, if $m \neq n$, the connected sum of m tori and the connected sum of n tori have nonisomorphic fundamental groups. Therefore, they are not of the same homotopy type. This is a stronger result than that proved in Chapter I, where it was shown that these spaces were not homeomorphic (assuming the proof that the Euler characteristic is a topological invariant).

5.4. The connected sum of n projective planes. The connected sum M of n projective planes can be obtained by identifying in pairs the sides of a $2n$ -gon, as shown in Figure 4.7. By carrying out exactly the same procedure as before,

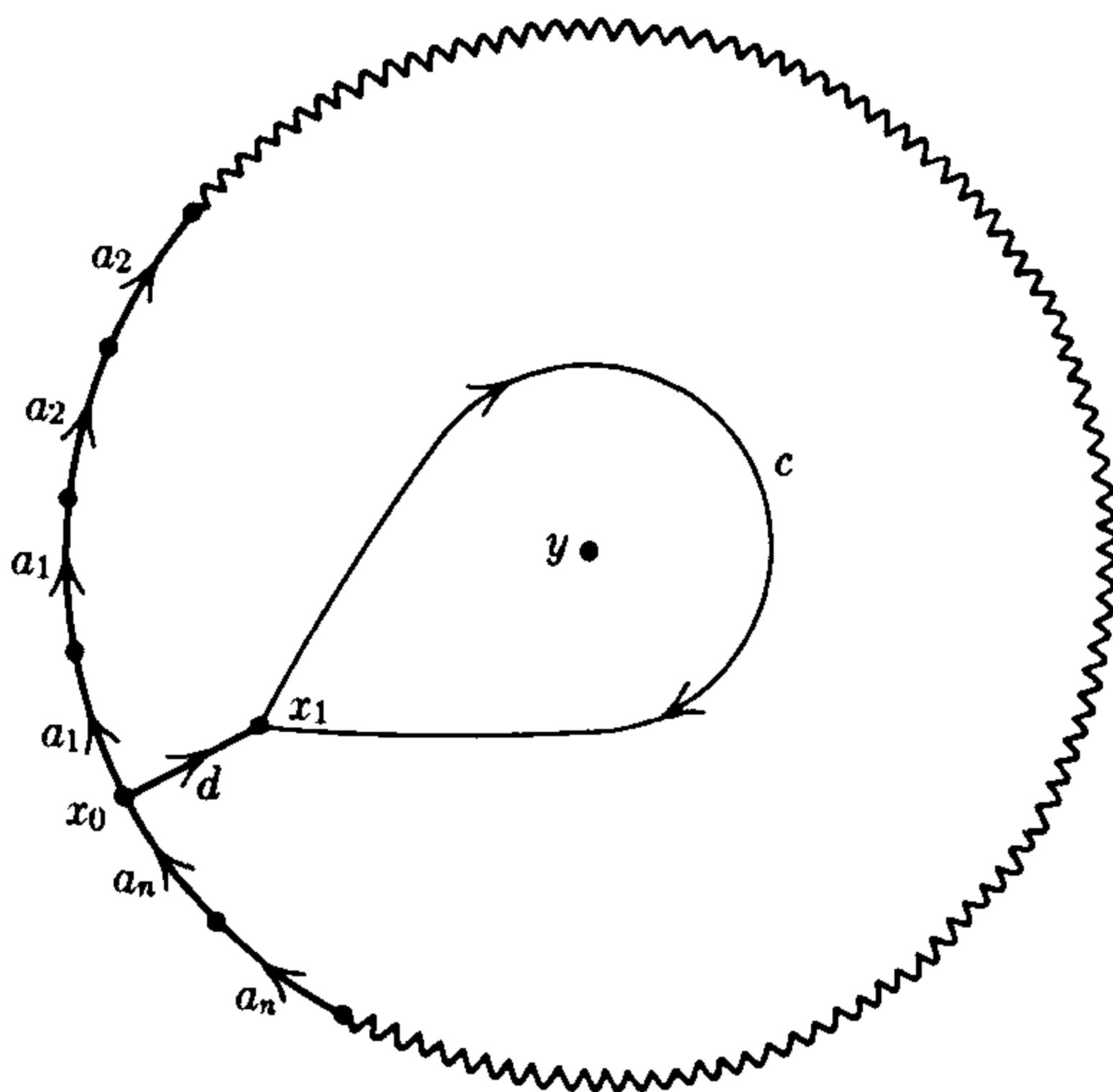

FIGURE 4.7. Determination of the fundamental group of a nonorientable surface of genus n (first method).

we find that the fundamental group $\pi(M, x_0)$ has a presentation consisting of the set of generators

$$\{\alpha_1, \alpha_2, \dots, \alpha_n\},$$

where α_i is represented by the circle a_i , and one relation

$$\alpha_1^2 \alpha_2^2 \dots \alpha_n^2.$$

For $n > 1$, this is again a group with no simple invariant description. If we abelianize, we obtain an abelian group which also has a presentation consisting of n generators and one relation. The reader who is familiar with the theory of finitely generated abelian groups can easily determine the rank and torsion coefficients of this group by reducing a certain integer matrix to canonical form. We shall do this by a more geometric procedure.

Using Theorem I.7.2, we see that M , a nonorientable surface of genus n , has the following alternative representation:

- (a) For n odd, M is homeomorphic to the connected sum of an orientable surface of genus $\frac{1}{2}(n - 1)$ and a projective plane.
- (b) For n even, M is homeomorphic to the connected sum of an orientable surface of genus $\frac{1}{2}(n - 2)$ and a Klein bottle.

This leads to the representation M as the space obtained by identifying the edges of $2n$ -gon in pairs as shown in Figure 4.8(a) and (b). In case (a), we see that $\pi(M, x_0)$ has a presentation with generators

$$\{\alpha_1, \beta_1, \dots, \alpha_k, \beta_k, \varepsilon\}$$

and one relation

$$[\alpha_1, \beta_1][\alpha_2, \beta_2] \cdots [\alpha_k, \beta_k] \varepsilon^2;$$

whereas in case (b) there is a presentation of $\pi(M, x_0)$ with generators

$$\{\alpha_1, \beta_1, \dots, \alpha_k, \beta_k, \alpha_{k+1}, \varepsilon\}$$

and the one relation

$$[\alpha_1, \beta_1][\alpha_2, \beta_2] \cdots [\alpha_k, \beta_k] \alpha_{k+1} \varepsilon \alpha_{k+1}^{-1} \varepsilon.$$

Using this presentation, we can easily determine the structure of the abelianized group,

$$\frac{\pi(M)}{[\pi(M), \pi(M)]}.$$

In case (a) it is the direct product of a free abelian group on the $2k$ generators $\{\alpha_1, \beta_1, \dots, \alpha_k, \beta_k\}$ and a cyclic group of order 2 (generated by ε); i.e., it is an abelian group of rank $2k = n - 1$ and with one torsion coefficient of order 2. In case (b) it is the direct product of a free abelian group on the $2k + 1$ generators $\{\alpha_1, \beta_1, \dots, \alpha_k, \beta_k, \alpha_{k+1}\}$ and a cyclic group of order 2 (generated by ε); i.e., it is an abelian group of rank $2k + 1 = n - 1$ with one torsion coefficient of order 2.

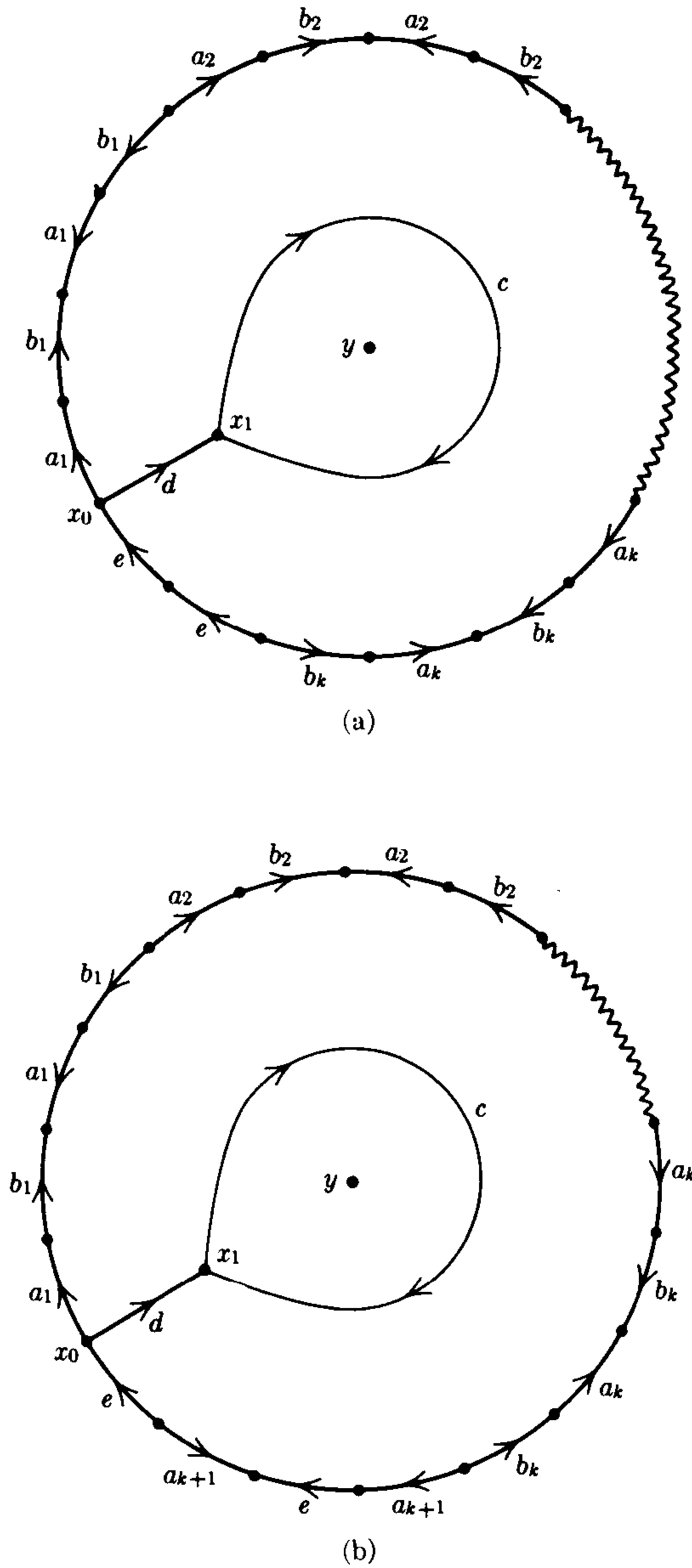

FIGURE 4.8. Determination of the fundamental group of a nonorientable surface of genus n (second method). (a) n odd, $k = \frac{1}{2}(n - 1)$. (b) n even, $k = \frac{1}{2}(n - 2)$.

We can summarize our results on the abelianized fundamental groups as follows:

Proposition 5.1. *If M is the connected sum of n tori, then the abelianized fundamental group, $\pi(M)/[\pi(M), \pi(M)]$ is a free abelian group of rank $2n$. If M is the connected sum of n projective planes, then the abelianized fundamental group is of rank $n - 1$, and has one torsion coefficient, which is of order 2.*

From this result we see that a compact, connected orientable manifold is never of the same homotopy type as a compact, connected nonorientable manifold, because the abelianized fundamental group of a nonorientable manifold always contains an element of order 2, whereas in the orientable case, every element is of infinite order. It also follows that, if $m \neq n$, then the connected sum of m projective planes and of n projective planes are not of the same homotopy type.

These results are a slight improvement on those of Chapter I, obtained by using the Euler characteristic.

EXERCISES

- 5.1. Show how to obtain geometrically the two different presentations of the fundamental group of a Klein bottle mentioned as an example in §III.6.
- 5.2. Consider the presentation of the fundamental group of the Klein bottle with two generators, a and b , and one relation, $baba^{-1}$. Prove that the subgroup generated by b is a normal subgroup, and that the quotient group is infinite cyclic. Prove also that the subgroup generated by a is infinite cyclic.
- 5.3. The fact that the connected sum of three projective planes is homeomorphic to the connected sum of a torus and a projective plane gives rise to two different presentations of the fundamental group (as in Problem 5.2). Prove algebraically that these presentations represent isomorphic groups.
- 5.4. For any integer $n > 2$, show how to construct a space whose fundamental group is cyclic of order n .
- 5.5. Prove that the fundamental group of a compact nonorientable surface of genus n has a presentation consisting of n generators, $\alpha_1, \dots, \alpha_n$, and one relation, $\alpha_1\alpha_2 \dots \alpha_n\alpha_1^{-1}\alpha_2^{-1} \dots \alpha_{n-1}^{-1}\alpha_n$ (see Exercise I.8.8).
- 5.6. Prove that the fundamental group of a compact, orientable surface of genus n has a presentation consisting of $2n$ generators, $\alpha_1, \alpha_2, \dots, \alpha_{2n}$, and one relation, $\alpha_1\alpha_2 \dots \alpha_{2n}\alpha_1^{-1} \dots \alpha_{2n}^{-1}$ (see Exercise I.8.9).

§6. Application to Knot Theory

A *knot* is, by definition, a simple closed curve in Euclidean 2-space. It is a mathematical abstraction of our intuitive idea of a knot tied in a piece of string; the two ends of the string are to be thought of as spliced together so that the knot can not become untied.

It is also necessary to define when two knots are to be thought of as equivalent or nonequivalent. Here it would be highly desirable to frame the definition so that it corresponds to the usual notion of two knots in two different pieces of string being the same. Of several alternative ways of doing this, the following definition is now universally accepted (as the result of many years of experience) as being the most suitable.

Definition. Two knots K_1 and K_2 contained in \mathbf{R}^3 are equivalent if there exists an orientation-preserving homeomorphism $h: \mathbf{R}^3 \rightarrow \mathbf{R}^3$ such that $h(K_1) = K_2$.

Obviously, if K_1 and K_2 are equivalent according to this definition, then h maps $\mathbf{R}^3 - K_1$ homeomorphically onto $\mathbf{R}^3 - K_2$. Therefore, $\mathbf{R}^3 - K_1$ and $\mathbf{R}^3 - K_2$ have isomorphic fundamental groups. Thus, given two knots K_1 and K_2 in \mathbf{R}^3 , if we can prove that the groups $\pi(\mathbf{R}^3 - K_1)$ and $\pi(\mathbf{R}^3 - K_2)$ are nonisomorphic, then we know the knots K_1 and K_2 are nonequivalent. This is the most common method of distinguishing between knots. The fundamental group $\pi(\mathbf{R}^3 - K)$ is called the *group of the knot* K .

We shall show how it is possible to use the Seifert–Van Kampen theorem to determine a presentation of the group of certain knots, and then discuss the problem of proving that these groups are nonisomorphic.

In certain cases, it will be convenient to think of the knots we shall consider as being imbedded in the 3-sphere S^3 ,

$$S^3 = \{x \in \mathbf{R}^4 : |x| = 1\}$$

rather than being imbedded in \mathbf{R}^3 . This makes little difference because S^3 is homeomorphic to the Alexandroff 1-point compactification of \mathbf{R}^3 ; this can be proved by stereographic projection (see M. H. A. Newman, *Elements of the Topology of Plane Sets of Points*, The University Press, Cambridge, 1951, pp. 64–65).

EXERCISES

6.1. If K is a knot in \mathbf{R}^3 and we regard S^3 as the 1-point compactification of \mathbf{R}^3 , prove that the fundamental groups $\pi(\mathbf{R}^3 - K)$ and $\pi(S^3 - K)$ are isomorphic. (HINT: Use Theorem 4.1.)

We shall consider a class of knots called *torus knots* because they are contained in a torus imbedded in \mathbf{R}^3 in the standard way (i.e., the torus is obtained by rotating a circle about a line in its plane). Recall that a torus may be considered as the space obtained by identifying the opposite edges of the unit square,

$$\{(x, y) \in \mathbf{R}^2 : 0 \leq x \leq 1, 0 \leq y \leq 1\}.$$

or, alternatively, as the space obtained from the entire plane \mathbf{R}^2 by identifying

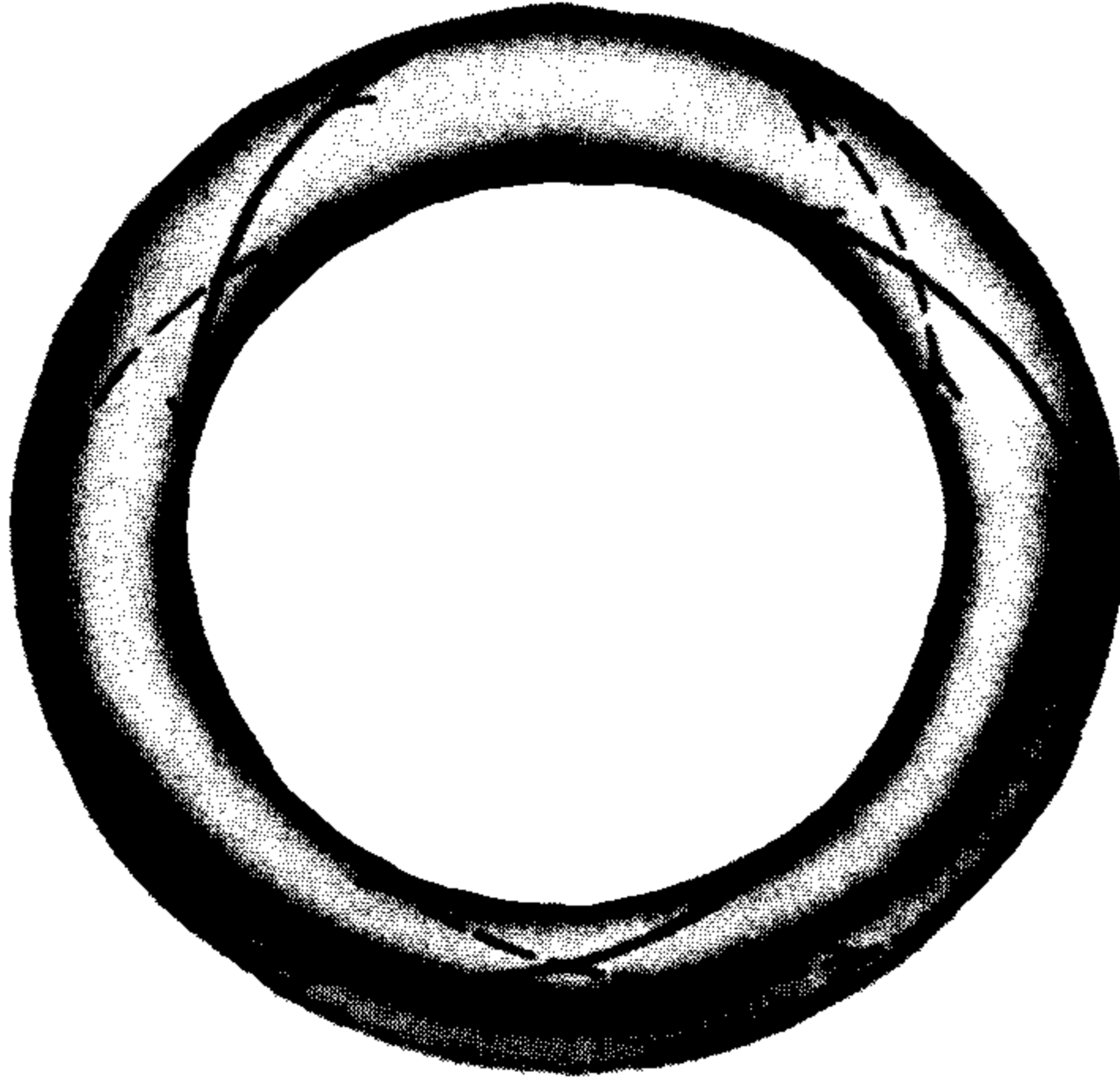

FIGURE 4.9. Torus knot of type (2, 3).

two points (x, y) and (x', y') if and only if $x - x'$ and $y - y'$ are both integers. Let $p: \mathbf{R}^2 \rightarrow T$ be the identification map. Let L be a line through the origin in \mathbf{R}^2 with slope m/n , where $1 < m < n$, and m and n are relatively prime integers. It is readily seen that the image

$$K = p(L)$$

is a simple closed curve on the torus T ; it spirals around the torus m times while going around it n times the other way. If we now assume that T is imbedded in \mathbf{R}^3 in the standard way, then

$$K \subset T \subset \mathbf{R}^3,$$

and K is a knot in \mathbf{R}^3 called a *torus knot of type* (m, n) . Such knots will be our main object of study.

We shall also consider *unknotted circles* in \mathbf{R}^2 , i.e., any knot equivalent to an ordinary Euclidean circle in a plane in \mathbf{R}^3 .

To begin, we obtain a presentation of the group of a torus knot of type (m, n) and of the group of an unknotted circle. The first step is to obtain a certain decomposition of the 3-sphere S^3 into two pieces, which is necessary for the use of the Seifert–Van Kampen theorem. Let

$$A = \{(x_1, x_2, x_3, x_4) \in S^3 : x_1^2 + x_2^2 \leq x_3^2 + x_4^2\},$$

$$B = \{(x_1, x_2, x_3, x_4) \in S^3 : x_1^2 + x_2^2 \geq x_3^2 + x_4^2\}.$$

It is clear that A and B are closed subsets of S^3 , that $A \cup B = S^3$, and that

$$A \cap B = \{(x_1, x_2, x_3, x_4) \in S^3 : x_1^2 + x_2^2 = \frac{1}{2} \text{ and } x_3^2 + x_4^2 = \frac{1}{2}\}.$$

From this it is clear that $A \cap B$ is a torus; in fact, it is the Cartesian product of the circle $x_1^2 + x_2^2 = \frac{1}{2}$ [in the (x_1, x_2) plane] and the circle $x_3^2 + x_4^2 = \frac{1}{2}$ [in the (x_3, x_4) plane].

We now assert that A and B are each solid tori (i.e., homeomorphic to the product of a disc and a circle). We shall prove this by exhibiting a homeomorphism. Let

$$D = \{(x_1, x_2) \in \mathbf{R}^2 : x_1^2 + x_2^2 \leq \frac{1}{2}\},$$

$$S^1 = \{(x_3, x_4) \in \mathbf{R}^2 : x_3^2 + x_4^2 = \frac{1}{2}\}$$

be a closed disc and a circle, each of radius $\frac{1}{2}\sqrt{2}$. Define a map

$$f : D \times S^1 \rightarrow A$$

by the formula

$$f(x_1, x_2, x_3, x_4) = (x_1, x_2, \sqrt{2}x_3[1 - (x_1^2 + x_2^2)]^{1/2}, \sqrt{2}x_4[1 - (x_1^2 + x_2^2)]^{1/2}).$$

This function is obviously continuous. We leave it to the reader to verify that it is one-to-one and onto, and hence a homeomorphism. A similar proof applies to the set B . It is also clear from this that the torus $A \cap B$ is the common boundary of the two solid tori A and B .

We leave it to the reader to verify that, under stereographic projection, the torus $A \cap B$ corresponds to a torus imbedded in \mathbf{R}^3 in the standard way.

First, we consider the group of an unknotted circle K in S^3 . We can take as our unknotted circle the "center line" of the solid torus A :

$$K = \{(x_1, x_2, x_3, x_4) \in A : x_1 = x_2 = 0\}.$$

Then, K is the unit circle in the (x_3, x_4) plane. Clearly, the boundary of A is a deformation retract of $A - K$; therefore B is a deformation retract of $S^3 - K$. It is also clear that the center line of B

$$\{(x_1, x_2, x_3, x_4) \in B : x_3 = x_4 = 0\},$$

is a deformation retract of B . Therefore, the center line of B is a deformation retract of $S^3 - K$. Hence, $S^3 - K$ has the homotopy type of a circle, and the group of K is infinite cyclic. Thus, we have proved.

Proposition 6.1. *The group of an unknotted circle in \mathbf{R}^3 is infinite cyclic.*

Next, we consider a torus knot K of type (m, n) in S^3 . We can consider K a subset of the torus $A \cap B \subset S^3$. It would be convenient to apply the Seifert–Van Kampen theorem to determine the fundamental group of $S^3 - K$ by using the fact that

$$S^3 - K = (A - K) \cup (B - K).$$

Then, $A - K$, $B - K$, and $(A - K) \cap (B - K)$ are all arcwise connected, but

unfortunately $A - K$ and $B - K$ are not open subsets of $S^3 - K$. The way around this difficulty is clear: We enlarge A and B slightly to obtain open sets with the same homotopy type as A and B .

To be precise, choose a number $\varepsilon > 0$ small enough so that, if N denotes a tubular neighborhood of K of radius ε , then $S^3 - N$ is a deformation retract of $S^3 - K$. It is clear that this will be the case provided ε is sufficiently small; the precise meaning of the phrase “sufficiently small” depends on the integers m and n . Then, let U and V be the $\frac{1}{2}\varepsilon$ neighborhoods of A and B , respectively. It is clear that U and V are each homeomorphic to the product of an open disc with a circle, and A and B are deformation retracts of U and V . Also, $U \cap V$ is a “thickened” torus, i.e., homeomorphic to the product of $A \cap B$ and the open interval $(-\frac{1}{2}\varepsilon, \frac{1}{2}\varepsilon)$. We can now use the fact that

$$S^3 - N = (U - N) \cup (V - N)$$

and apply the Seifert–Van Kampen theorem to arrive at a presentation of $\pi(S^3 - N) \approx \pi(S^3 - K)$.

First, $U - N$ and $V - N$ both have the homotopy type of a circle; in fact, the center lines of A and B are deformation retracts of these two spaces. Therefore, their fundamental groups are infinite cyclic.

Second, the spaces $(U - N) \cap (V - N) = (U \cap V) - N$ and $(A - K) \cap (B - K) = (A \cap B) - K$ both have the same homotopy type. In fact, the set $(A - N) \cap (B - N) = (A \cap B) - N$ is a deformation retract of each of these spaces. We can readily see that $(A \cap B) - K$ is a subset of the torus $A \cap B$ homeomorphic to the product of a circle with an open interval. It is a strip wound spirally around the torus, like a bandage. Its fundamental group is infinite cyclic.

Finally, we must determine the homomorphisms

$$\varphi_1 : \pi(U \cap V - N) \rightarrow \pi(U - N),$$

$$\varphi_2 : \pi(U \cap V - N) \rightarrow \pi(V - N).$$

Here we leave the details to the reader. The result is that one of these homomorphisms is of degree m , and the other is of degree n . (We say a homomorphism of one infinite cyclic group into another is of degree m if the image of a generator of the first group is the m th power of a generator of the second group.) If we combine this result with Exercise 4.1(c) we obtain the following result:

Proposition 6.2. *The group G of a torus knot of type (m, n) has a presentation consisting of two generators, $\{\alpha, \beta\}$, and one relation, $\alpha^m \beta^n$.*

There remains the task of proving that these groups are nonisomorphic for different values of the pair (m, n) . This we now do by a method due to O. Schreier. Consider the element $\alpha^m = \beta^{-n}$ in this group. This element commutes with α and β , and hence with every element; thus it belongs to the center. Let

N denote the subgroup generated by this element; it is obviously a normal subgroup. Consider the quotient group G/N . Let α' and β' denote the coset of α and β in G/N . Obviously, G/N is generated by the elements α' and β' , and it has the following presentation:

$$\text{Generators: } \alpha', \beta' \quad \text{Relations: } \alpha'^m, \beta'^n.$$

From this presentation, it follows that G/N is the free product of a cyclic group of order m (generated by α') and a cyclic group of order n (generated by β'). The proof, which is not difficult, is left to the reader. We now apply Exercise III.4.1 to conclude that the center of G/N is $\{1\}$. Because the image of the center of G is contained in the center of G/N , it follows that N is the entire center of G . Thus, the quotient of G by its center is the free product of two cyclic groups (of order m and n). We can now apply the result of Exercise III.4.6 to conclude that the integers m, n are completely determined (up to their order) by G . Thus, we have proved the following.

Proposition 6.3. *If torus knots of types (m, n) and (m', n') are equivalent, then $m = m'$ and $n = n'$, or else $m = n'$ and $n = m'$. No torus knot is equivalent to an unknotted circle (assuming $m, n > 1$).*

Thus, by means of torus knots we have constructed an infinite family of nonequivalent knots.

Of course, most knots are not torus knots. The foregoing paragraphs should only be considered a brief introduction to the subject of knot theory. The reader who wishes to learn more about this subject can consult the following books: Burde and Zieschang [2], Crowell and Fox [4], Kauffman [6], Moran [7], Neuwirth [8], or Rolfsen [12].

§7. Proof of Lemma 2.4

For the convenience of the reader, we will restate Lemma 2.4. The hypotheses and notation are listed in §2.

Lemma 2.4. *Let $\beta_i \in \pi(U_{\lambda_i})$, $i = 1, \dots, q$ be such that*

$$\psi_{\lambda_1}(\beta_1) \cdot \psi_{\lambda_2}(\beta_2) \cdot \dots \cdot \psi_{\lambda_q}(\beta_q) = 1.$$

Then, the product

$$\rho_{\lambda_1}(\beta_1) \rho_{\lambda_2}(\beta_2) \cdot \dots \cdot \rho_{\lambda_q}(\beta_q) = 1.$$

PROOF. Choose closed paths

$$f_i: \left[\frac{i-1}{q}, \frac{i}{q} \right] \rightarrow U_{\lambda_i}$$

representing β_i for $i = 1, 2, \dots, q$. Then, the product

$$\prod_{i=1}^q \psi_{\lambda_i}(\beta_i)$$

is clearly represented by the closed path $f: [0, 1] \rightarrow X$ defined by

$$f \left| \left[\frac{i-1}{q}, \frac{i}{q} \right] \right. = f_i, \quad i = 1, 2, \dots, q.$$

By hypothesis, f is equivalent to the constant path. Hence, there exists a continuous map

$$F: I \times I \rightarrow X$$

such that, for any $s, t \in I$,

$$F(s, 0) = f(s),$$

$$F(s, 1) = F(0, t) = F(1, t) = x_0.$$

Let ε denote the Lebesgue number of the open covering $\{F^{-1}(U_\lambda) : \lambda \in \Lambda\}$ of the compact metric space $I \times I$ (we give $I \times I$ the metric it has as a subset of the Euclidean plane). We now subdivide the square $I \times I$ into smaller rectangles of diameter $< \varepsilon$ as follows. Choose numbers

$$s_0 = 0, \quad s_1, s_2, \dots, s_m = 1,$$

$$t_0 = 0, \quad t_1, t_2, \dots, t_n = 1,$$

such that the following three conditions hold: (a) $s_0 < s_1 < s_2 < \dots < s_m$ and $t_0 < t_1 < t_2 < \dots < t_n$; (b) the fractions $1/q, 2/q, \dots, (q-1)/q$ are included among the numbers s_1, s_2, \dots, s_m ; (c) if we subdivide the unit square $I \times I$ into rectangles by the vertical and horizontal lines,

$$s = s_i, \quad i = 0, 1, \dots, m,$$

$$t = t_j, \quad j = 0, 1, \dots, n,$$

the length of the diagonal of each rectangle is less than ε . Clearly, such a subdivision is possible.

Before proceeding further with the proof, we must introduce a rather elaborate notation for the various vertices, edges, and rectangles of this subdivision as follows.

Vertices:

$$v_{ij} = (s_i, t_j), \quad 0 \leq i \leq m, 0 \leq j \leq n.$$

Subintervals of $I = [0, 1]$:

$$J_i = [s_{i-1}, s_i], \quad 1 \leq i \leq m,$$

$$K_j = [t_{j-1}, t_j], \quad 1 \leq j \leq n.$$

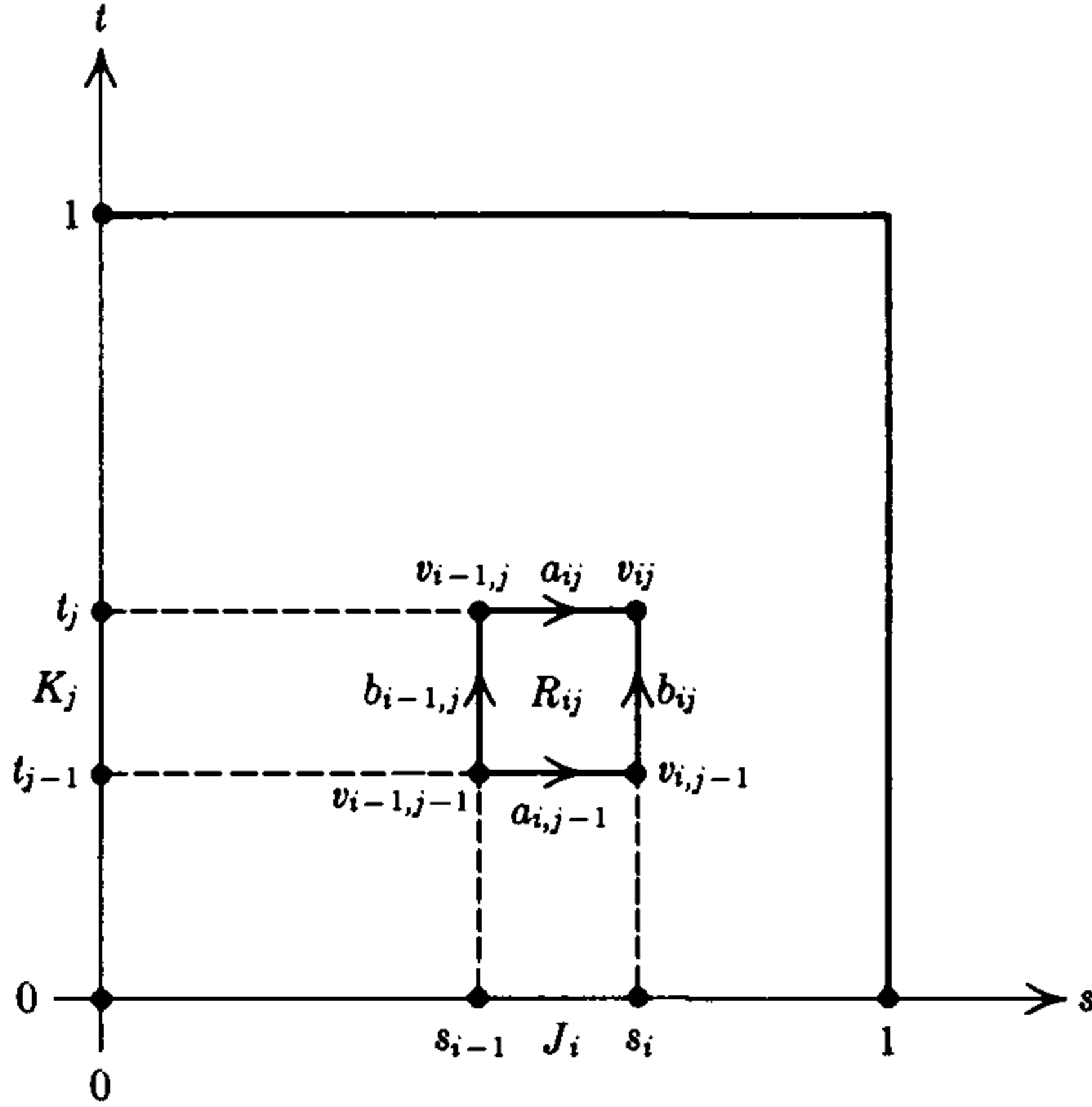

FIGURE 4.10. Notation used in the proof of Lemma 2.4.

Rectangles:

$$R_{ij} = J_i \times K_j, \quad 1 \leq i \leq m, 1 \leq j \leq n.$$

Horizontal edges:

$$a_{ij} = J_i \times \{t_j\}, \quad 1 \leq i \leq m, 1 \leq j \leq n.$$

Vertical edges:

$$b_{ij} = \{s_i\} \times K_j, \quad 0 \leq i \leq m, 1 \leq j \leq n.$$

In Figure 4.10 we indicate how a typical rectangle of this subdivision and its vertices and edges are labeled. We also need the following notation for certain paths:

$$A_{ij}: J_i \rightarrow X, \quad A_{ij}(s) = F(S, t_j), \quad s \in J_i.$$

$$B_{ij}: K_j \rightarrow X, \quad B_{ij}(t) = F(s_i, t), \quad t \in K_j.$$

With a slight abuse of notation, we can write

$$A_{ij} = F|a_{ij},$$

$$B_{ij} = F|b_{ij}.$$

For each rectangle R_{ij} , choose an open set $U_{\lambda(i,j)}$ such that

$$F(R_{i,j}) \subset U_{\lambda(i,j)}.$$

Condition (c) on the subdivisions assures us that such a choice is possible.

Each vertex v_{ij} is a vertex of 1, 2, or 4 of the rectangles R_{kl} ; let $U_{\mu(i,j)}$ denote the intersection of the corresponding 1, 2, or 4 open sets $U_{\lambda(k,l)}$. Then, $U_{\mu(i,j)}$ is an open set of the given covering and

$$F(v_{ij}) \in U_{\mu(i,j)}.$$

Choose a path

$$g_{ij}: I \rightarrow U_{\mu(i,j)}$$

with initial point x_0 and terminal point $F(v_{ij})$; if $F(v_{ij}) = x_0$, we require that g_{ij} be the constant path.

Having introduced most of the necessary notation, we now interpolate a sublemma.

Sublemma. *Let U_λ and U_μ be two sets of the given open covering of X and let*

$$h: I \rightarrow U_\lambda \cap U_\mu, \quad h(0) = h(1) = x_0,$$

be a closed path. Let $\alpha \in \pi(U_\lambda, x_0)$ and $\beta \in \pi(U_\mu, x_0)$ denote the equivalence class of the loop h in the two different groups. Then, $\rho_\lambda(\alpha) = \rho_\mu(\beta)$.

PROOF OF SUBLEMMA. The set $U_\nu = U_\lambda \cap U_\mu$ also belongs to the covering by hypothesis, and h represents an element $\gamma \in \pi(U_\nu, x_0)$. Then, clearly,

$$\alpha = \varphi_{\nu\lambda}(\gamma),$$

$$\beta = \varphi_{\nu\mu}(\gamma).$$

Hence,

$$\rho_\lambda(\alpha) = \rho_\lambda \varphi_{\nu\lambda}(\gamma) = \rho_\nu(\gamma),$$

$$\rho_\mu(\beta) = \rho_\mu \varphi_{\nu\mu}(\gamma) = \rho_\nu(\gamma).$$

Q.E.D.

This sublemma enables us to adopt a certain sloppiness of notation without fear of ambiguity. We can denote the element $\rho_\lambda(\alpha) = \rho_\mu(\beta) \in H$ by the notation $\rho(h)$; we need not worry about whether we should take the equivalence class of h in the group $\pi(U_\lambda)$ or in the group $\pi(U_\mu)$.

With this convention, let

$$\alpha_{ij} = \rho[(g_{i-1,j}A_{ij})(g_{ij})^{-1}],$$

$$\beta_{ij} = \rho[(g_{i,j-1}B_{ij})(g_{ij})^{-1}].$$

[Here $(g_{ij})^{-1}$ denotes the path defined by $t \rightarrow g_{ij}(1 - t)$.] Note that α_{ij} and β_{ij} are both well-defined elements of H .

Next, we assert that, corresponding to each rectangle R_{ij} , there is a relation of the following form in the group H :

$$\alpha_{i,j-1}\beta_{ij} = \beta_{i-1,j}\alpha_{ij}. \tag{4.7.3}$$

To prove this, note first that we have the following equivalence between (nonclosed) paths in $U_{\lambda(i,j)}$:

$$A_{i,j-1}B_{ij} \sim B_{i-1,j}A_{ij}.$$

This equivalence is a consequence of Lemma II.8.1 applied to the mapping $F|R_{ij}: R_{ij} \rightarrow U_{\lambda(i,j)}$ and Exercise II.3.3. As a result, we have the following equivalence between closed paths in $U_{\lambda(i,j)}$:

$$g_{i-1,j-1}A_{i,j-1}(g_{i,j-1})^{-1}g_{i,j-1}B_{ij}(g_{ij})^{-1} \sim g_{i-1,j-1}B_{i-1,j}(g_{i-1,j})^{-1}g_{i-1,j}A_{ij}(g_{ij})^{-1}. \quad (4.7.4)$$

If we now take the equivalence class in $\pi(U_{\lambda(i,j)})$ of both sides, and then apply the homomorphism $\rho_{\lambda(i,j)}$, we obtain equation (4.7.3). [NOTE: To be strictly correct, since multiplication of paths is not associative, parentheses should be inserted in (4.7.4). However, it does not matter how the parentheses are inserted.]

The next relation we need is

$$\prod_{i=1}^m \alpha_{i0} = \prod_{k=1}^q \rho_{\lambda_k}(\beta_k), \quad (4.7.5)$$

which is an easy consequence of requirement (b) that the points $1/q, 2/q, \dots, (q-1)/q$ be included in the set $\{s_i: 0 < i < m\}$ together with the definitions and constructions we have made. Finally, we have the relations

$$\alpha_{in} = 1, \quad 1 \leq i \leq m, \quad (4.7.6)$$

$$\beta_{0j} = \beta_{mj} = 1, \quad 1 \leq j \leq n. \quad (4.7.7)$$

These relations result from the fact that

$$F(s, 1) = F(0, t) = F(1, t) = x_0$$

for any, $s, t \in I$.

In view of relation (4.7.5), we must prove

$$\prod_{i=1}^m \alpha_{i0} = 1. \quad (4.7.8)$$

We shall now do this by using relations (4.7.3), (4.7.6), and (4.7.7). First, we show that

$$\prod_{i=1}^m \alpha_{i,j-1} = \prod_{i=1}^m \alpha_{i,j} \quad (4.7.9)$$

for any integer $j, 1 \leq j \leq n$. Indeed, we have

$$\begin{aligned} \alpha_{1,j-1}\alpha_{2,j-1}\cdots\alpha_{m,j-1} &= \alpha_{1,j-1}\alpha_{2,j-1}\cdots\alpha_{m,j-1}\beta_{m,j} && \text{by (4.7.7)} \\ &= \alpha_{1,j-1}\alpha_{2,j-1}\cdots\alpha_{m-1,j-1}\beta_{m-1,j}\alpha_{m,j} && \text{by (4.7.3)} \\ &= \alpha_{1,j-1}\alpha_{2,j-1}\cdots\beta_{m-2,j}\alpha_{m-1,j}\alpha_{m,j} && \text{by (4.7.3)} \\ &= \vdots && \vdots \\ &= \beta_{0j}\alpha_{1,j}\alpha_{2,j}\cdots\alpha_{m-1,j}\alpha_{m,j} && \text{by (4.7.3)} \\ &= \alpha_{1,j}\alpha_{2,j}\cdots\alpha_{m-1,j}\alpha_{m,j}. && \text{by (4.7.7)} \end{aligned}$$

In all, we must apply (4.7.3) m times. If we now apply (4.7.9) with $j = 1, 2, \dots, n$ in succession, we obtain

$$\prod_{i=1}^m \alpha_{i0} = \prod_{i=1}^m \alpha_{in}.$$

But, by use of (4.7.6),

$$\prod_{i=1}^m \alpha_{in} = 1.$$

This completes the proof of (4.7.8), and hence of Lemma 2.4.

Q.E.D.

NOTES

Apparently a theorem along the lines of Theorem 2.1 was first proved by H. Seifert in 1931 in a paper entitled “Konstruktion dreidimensionaler geschlossener Räume” [*Ber. Sächs. Akad. Wiss.* **83** (1931), 26–66]. A little later a similar theorem was discovered and proved independently by E. R. Van Kampen [“On the connection between the fundamental groups of some related spaces,” *Am. J. Math.* **55** (1933), 261–267]. In spite of this, it is usually referred to as “Van Kampen’s theorem” in American books and papers. Of course, the formulation of the theorem as the solution of a universal mapping problem came later. Our exposition is based on a paper by R. H. Crowell [3], which was apparently inspired by lectures of R. H. Fox at Princeton; see their joint textbook [4].

Free products with amalgamated subgroups

Let $\{W\} \cup \{V_i : i \in I\}$ be a covering of X by arcwise-connected open sets such that $V_i \cap V_j = W$ if $i \neq j$ and $x_0 \in W$ (see Exercise 3.1). Assume that, for each index i , the homomorphism $\pi(W, x_0) \rightarrow \pi(V_i, x_0)$ is a *monomorphism*. Then, the fundamental group $\pi(X, x_0)$, as specified by Theorem 2.2, has a structure that has been well studied by group theorists; it is called a “free product with amalgamated subgroup.” It is a quotient group of the free product of the groups $\pi(V_i)$ obtained by “amalgamating” or identifying the various subgroups which correspond to $\pi(W, x_0)$ under the given monomorphisms. Every element of such a free product with amalgamated subgroups has a unique expression as a “word in canonical form.” Such groups are important in certain aspects of group theory and have also been used in topology. For further information on this subject, see the textbooks on group theory listed in the bibliography of Chapter III.

The Poincaré conjecture

It follows from the computations made in this chapter that any simply-connected, compact surface is homeomorphic to the 2-sphere S^2 . Poincaré conjectured in the early 1900s that an analogous statement is true for 3-manifolds, namely, that a compact, simply-connected 3-manifold is homeo-

morphic to the 3-sphere S^3 . In spite of the expenditure of much effort by many outstanding mathematicians over the years since Poincaré, it is still unknown whether or not this famous conjecture is true. It is easy to give examples of compact, simply-connected 4-manifolds which are not homeomorphic to S^4 (e.g., $S^2 \times S^2$). However, for all integers $n > 3$ there is an analog of the Poincaré conjecture, namely, that a compact n -manifold that has the homotopy type of an n -sphere is homeomorphic to S^n . This generalized Poincaré conjecture was proved for $n > 4$ by S. Smale in 1960 [see *Ann. Math.* 74 (1961), 391–406]. The case where $n = 4$ was proved by Michael Freedman in 1982.

Until the classical Poincaré conjecture (the case where $n = 3$) is settled, we cannot hope to have a classification theorem for compact 3-manifolds.

Homotopy type vs. topological type for compact manifolds

From the computations of the fundamental groups of compact surfaces in this chapter, the following fact emerges: If two compact surfaces are not homeomorphic, then they do not have the same homotopy type. The analogous statement for compact 3-manifolds is known to be false; there are fairly simple examples of compact 3-dimensional manifolds which are of the same homotopy type, but not homeomorphic (the so-called “lens spaces”). The proof of this fact is the culmination of the work of mathematicians in several countries over a period of years. The details are rather elaborate.

Higher-dimensional examples of manifolds which are of the same homotopy type but not homeomorphic have been constructed by using a theorem of S. P. Novikov (topological invariance of rational Pontrjagin classes).

Fundamental group of a noncompact surface

The fundamental group of any noncompact surface (with a countable basis) is a free group on a countable or finite set of generators. Any simply-connected, noncompact surface is homeomorphic to the plane \mathbf{R}^2 . For a proof of these facts, see Ahlfors and Sario [1, Chapter I].

Sketch of the proof that any finitely presented group can be the fundamental group of a compact 4-manifold

First, note that the fundamental group of $S^1 \times S^3$ is infinite cyclic. Hence, by forming the connected sum of n copies of $S^1 \times S^3$, we obtain an orientable, compact 4-manifold whose fundamental group is a free group on n generators (see Exercise 3.7).

Next, suppose that M is a compact, orientable 4-manifold and C is a smooth, simply closed curve in M ; it may be shown that any sufficiently small, closed tubular neighborhood N of C is homeomorphic to $S^1 \times E^3$ (this assertion would not be true if M were nonorientable). Also, the boundary of N is homeomorphic to $S^1 \times S^2$. Now $S^1 \times S^2$ is also the boundary of $E^2 \times S^2$, a 4-dimensional manifold with boundary. Let M' denote the complement of

the interior of N . Form a quotient space of $M' \cup (E^2 \times S^2)$ by identifying corresponding points of the boundary of N and the boundary of $E^2 \times S^2$; denote the quotient space by M_1 . Then, M_1 is readily seen to be a compact, orientable 4-manifold also; the process of obtaining M_1 from M is often called “surgery.”

What is the fundamental group of M_1 ? We can answer this question by applying the Seifert–Van Kampen theorem twice. First, $M = M' \cup N$ and $M' \cap N$ is homeomorphic to $S^1 \times S^2$. It is readily seen that the homomorphism $\pi(M' \cap N) \rightarrow \pi(N)$ (induced by the inclusion) is an isomorphism; therefore by Exercise 4.1(a) the homomorphism $\pi(M') \rightarrow \pi(M)$ is also an isomorphism. Next, $M_1 = M' \cup (E^2 \times S^2)$ and $M' \cap (E^2 \times S^2) = M' \cap N$. Because $E^2 \times S^2$ is simply connected, Theorem 4.1 is applicable, and we can conclude that $\pi(M') \rightarrow \pi(M_1)$ is an epimorphism, and the kernel is the smallest normal subgroup containing the image of $\pi(M' \cap N) \rightarrow \pi(M')$; but it is readily seen that the images of $\pi(M' \cap N) \rightarrow \pi(M')$ and $\pi(C) \rightarrow \pi(M)$ are equivalent. (NOTE: Actually, each time we apply the Seifert–Van Kampen theorem, it is necessary to make use of deformation retracts, etc., because M' and N are not open subsets of M .)

We can summarize the conclusion just obtained as follows: $\pi(M_1)$ is naturally isomorphic to the quotient of $\pi(M)$ by the smallest normal subgroup containing the image of $\pi(C) \rightarrow \pi(M)$. In other words, we have “killed off” the element α of $\pi(M)$ represented by the closed path C . If the group $\pi(M)$ is presented by means of generators and relations, then $\pi(M_1)$ has a presentation consisting of the same set of generators and having one additional relation, namely, α .

It is not difficult to show that any element $\alpha \in \pi(M)$ can be represented by a smooth closed path C without any self-intersections, as required in the preceding argument. In fact, this is true for any orientable n -manifold M provided $n \geq 3$. In a manifold of dimension ≥ 3 there is enough “room” to get rid of the self-intersections in any closed path by means of arbitrarily small deformations.

Now let G be a group which has as a presentation consisting of n generators x_1, \dots, x_n and k relations r_1, r_2, \dots, r_k . Let M be the connected sum of n copies of $S^1 \times S^3$; then $\pi(M)$ is a free group on n generators, which we may denote by x_1, \dots, x_n . We now perform surgery k times on M , killing off in succession the elements r_1, \dots, r_k . The result will be a compact, orientable 4-manifold M_k such that $\pi(M_k) \approx G$, as required.¹

This construction was utilized by A. A. Markov in his proof that there cannot exist any algorithm for deciding whether or not two given compact, orientable, triangulable 4-manifolds are homeomorphic. Markov’s proof depends on the fact that there exists no general algorithm for deciding whether or not two given group presentations represent isomorphic groups (see *Proceedings of International Congress of Mathematicians*, 1958, pp. 300–306; also,

¹ This result is due to Seifert and Threlfall [9, p. 187].

W. Boone, W. Haken, and V. Poenaru, “On Recursively Unsolvable Problems in Topology and Their Classification” in *Contributions to Mathematical Logic*, edited by H. Schmidt, K. Schutte and H.-J. Thiele, North-Holland, Amsterdam, 1968, pp. 37–74).

Alternative proof of the Seifert–Van Kampen theorem

There is another method of proving the theorem of Seifert and Van Kampen, using the theory of covering spaces as described in the next chapter. Although this proof is not as long as that given in §2, it uses more machinery and requires the assumption of additional hypotheses. An exposition of this proof is given in the French text Godbillon [10] and in the research paper Knill [11].

References

1. L. V. Ahlfors and L. Sario, *Riemann Surfaces*, Princeton University Press, Princeton, N.J., 1960, Chapter I.
2. G. Burde and H. Zieschang, *Knots*, W. De Gruyter, Berlin and New York, 1985.
3. R. H. Crowell, On the Van Kampen Theorem. *Pac. J. Math.* **9** (1959), 43–50.
4. R. H. Crowell and R. H. Fox, *Introduction to Knot Theory*, Ginn, Boston, 1963, Chapter V and Appendix III (reprinted by Springer-Verlag, New York, 1977).
5. P. J. Hilton and S. Wylie, *Homology Theory, an Introduction to Algebraic Topology*, The University Press, Cambridge, 1960, Chapter VI.
6. L. Kauffman, *On Knots*, Princeton University Press, Princeton, N.J., 1987.
7. S. Moran, *The Mathematical Theory of Knots and Braids: An Introduction*, North-Holland, Amsterdam; 1983.
8. L. P. Neuwirth, *Knot Groups* (Annals of Mathematics Studies No. 56), Princeton University Press, Princeton, N.J., 1965.
9. H. Seifert and W. Threlfall, *A Textbook of Topology*, Academic Press, New York, 1980, Chapter 7.
10. C. Godbillon, *Éléments de Topologie Algébrique*, Hermann, Paris, 1971, Chapters VI and X.
11. R. J. Knill, The Seifert and Van Kampen Theorem via Regular Covering Spaces, *Pacific J. Math.* **49** (1973), 149–160.
12. D. Rolfsen, *Knots and Links*, Publish or Perish, Inc., Berkeley, 1976.

CHAPTER V

Covering Spaces

§1. Introduction

Let X be a topological space: a *covering space of X* consists of a space \tilde{X} and a continuous map p of \tilde{X} onto X which satisfies a certain very strong smoothness requirement. The precise definition is given below. The theory of covering spaces is important not only in topology, but also in related disciplines such as differential geometry, the theory of Lie groups, and the theory of Riemann surfaces.

The theory of covering spaces is closely connected with the study of the fundamental group. Many basic topological questions about covering spaces can be reduced to purely algebraic questions about the fundamental groups of the various spaces involved. It would be practically impossible to give a complete exposition of either one of these two topics without also taking up the other.

§2. Definition and Some Examples of Covering Spaces

In this chapter, we shall assume that *all spaces are arcwise connected and locally arcwise connected* (see §II.2 for the definition) unless otherwise stated. To save words, we shall not keep repeating this assumption. On the other hand, it is not necessary to assume that the spaces we are dealing with satisfy any separation axioms.

Definition. Let X be a topological space. A *covering space* of X is a pair consisting of a space \tilde{X} and a continuous map $p: \tilde{X} \rightarrow X$ such that the following condition holds: Each point $x \in X$ has an arcwise-connected open neighborhood U such that each arc component of $p^{-1}(U)$ is mapped topologically onto U by p [in particular, it is assumed that $p^{-1}(U)$ is nonempty]. Any open neighborhood U that satisfies the condition just stated is called an *elementary neighborhood*. The map p is often called a *projection*.

To clarify this definition, we now give several examples. In some of the examples our discussion will be rather informal, which is often more helpful than a more rigorous and formal discussion in getting an intuitive feeling for the concept of covering space.

Examples

2.1. Let $p: \mathbf{R} \rightarrow S^1$ be defined by

$$p(t) = (\sin t, \cos t)$$

for any $t \in \mathbf{R}$. Then, the pair (\mathbf{R}, p) is a covering space of the unit circle S^1 . Any open subinterval of the circle S^1 can serve as an elementary neighborhood. This is one of the simplest and most important examples.

2.2. Let us use polar coordinates (r, θ) in the plane \mathbf{R}^2 . Then, the unit circle S^1 is defined by the condition $r = 1$. For any integer n , positive or negative, define a map $p_n: S^1 \rightarrow S^1$ by the equation

$$p_n(1, \theta) = (1, n\theta).$$

The map p_n wraps the circle around itself n times. It is readily seen that, if $n \neq 0$, the pair (S^1, p_n) is a covering space of S^1 . Once again, any proper open interval in S^1 is an elementary neighborhood.

2.3. If X is any space, and $i: X \rightarrow X$ denotes the identity map, then the pair (X, i) is a trivial example of a covering space of X . Similarly, if f is a homeomorphism of Y onto X , then (Y, f) is a covering space of X , which is also a rather trivial example. Later in this chapter, we shall prove that, if X is simply connected, then any covering space of X is one of these trivial covering spaces. Thus, we can only hope for nontrivial examples of covering spaces in the case of spaces that are not simply connected.

2.4. If (\tilde{X}, p) is a covering space of X , and (\tilde{Y}, q) is a covering space of Y , then $(\tilde{X} \times \tilde{Y}, p \times q)$ is a covering space of $X \times Y$ [the map $p \times q$ is defined by $(p \times q)(x, y) = (px, qy)$]. We leave the proof to the reader. It is clear that, if U is an elementary neighborhood of the point $x \in X$ and V is an elementary neighborhood of the point $y \in Y$, then $U \times V$ is an elementary neighborhood of $(x, y) \in X \times Y$.

Using this result and Examples 2.1 and 2.2, the reader can construct examples of covering spaces of the torus $T = S^1 \times S^1$. In particular, the plane $\mathbf{R}^2 = \mathbf{R} \times \mathbf{R}$, the cylinder $\mathbf{R} \times S^1$, or the torus itself can serve as a covering

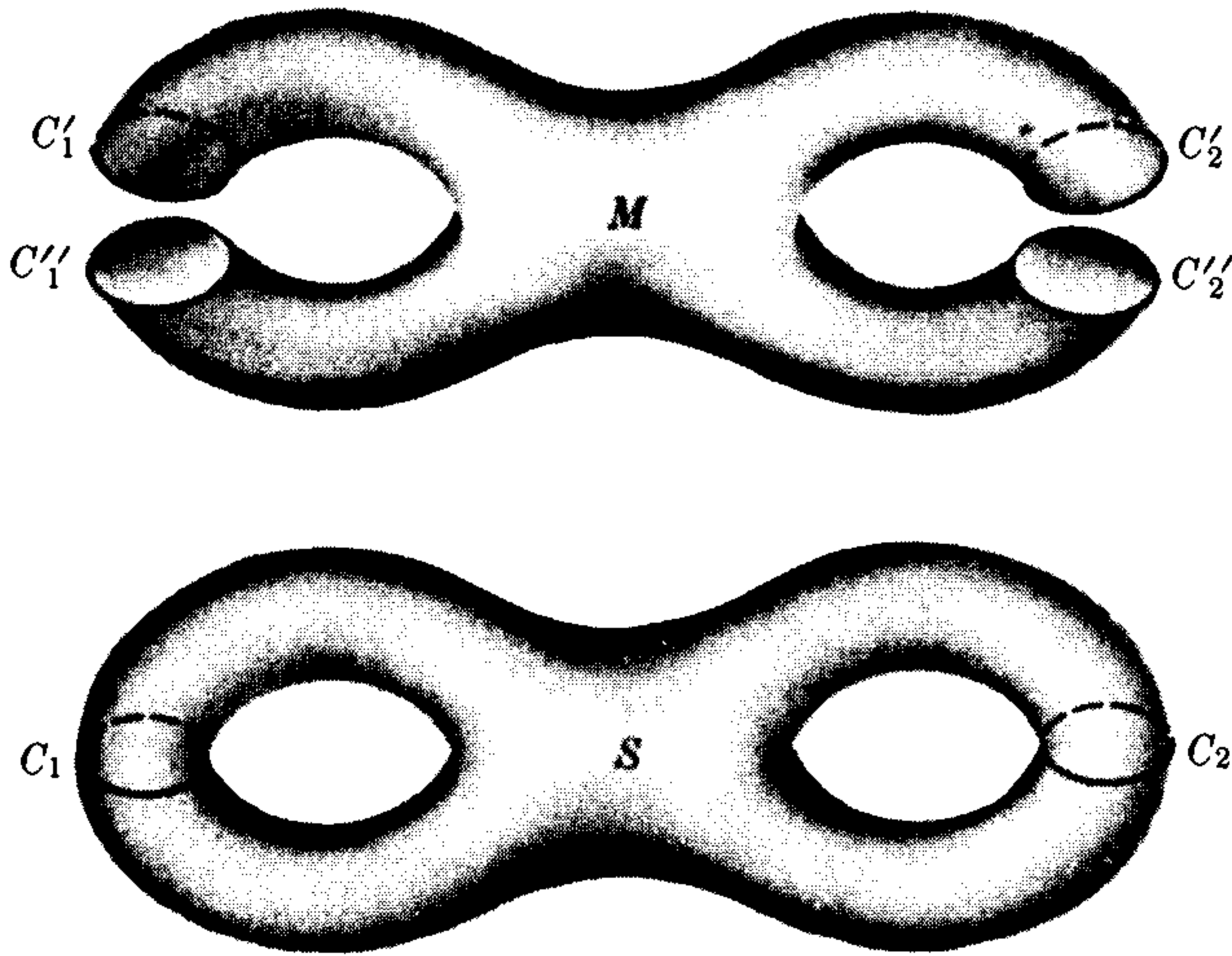

FIGURE 5.1. A surface of genus 2 as a quotient space of a bordered surface.

space of the torus. The reader should try to visualize the projection p involved in each of these cases.

2.5. In §I.4, the projective plane P was defined as a quotient space of the 2-sphere S^2 . Let $p : S^2 \rightarrow P$ denote the natural map. Then, it is readily seen that (S^2, p) is a covering space of P . We can take as an elementary neighborhood of any point $x \in P$ an open disc containing x .

2.6. Let S be a compact, orientable surface of genus 2. We shall show how to construct a great variety of covering spaces of S . Note that we can regard S as a quotient space of a compact, bordered surface M , where M is orientable, of genus 0, and its boundary consists of four circles $C'_1, C''_1, C'_2,$ and C''_2 . The natural map $M \rightarrow S$ identifies the boundary circles in pairs (see Figure 5.1): C'_i and C''_i are identified to a single circle C_i by means of a homeomorphism h_i of C'_i onto $C''_i, i = 1, 2$. We can also think of M as obtained from S by cutting along the circles C_1 and C_2 .

Let D be the finite set $\{1, 2, 3, \dots, n\}$ with the discrete topology and $q : M \times D \rightarrow M$, the projection of the product space onto the first factor. We can think of $M \times D$ as consisting of n disjoint copies of M , each of which is mapped homeomorphically onto M by q . We now describe how to form a quotient space of $M \times D$, which will be a connected 2-manifold \tilde{S} and such that the map q will induce a map $p : \tilde{S} \rightarrow S$ of quotient spaces; i.e., so we will have a commutative diagram

$$\begin{array}{ccc}
 M \times D & \longrightarrow & \tilde{S} \\
 \downarrow q & & \downarrow p \\
 M & \longrightarrow & S
 \end{array}$$

It will turn out that (\tilde{S}, p) is a covering space of S . The identification by which we form \tilde{S} from $M \times D$ will all be of the following form: The circle $C'_i \times \{j\}$ is identified with the circle $C''_i \times \{k\}$ by a homeomorphism which sends the point (x, j) onto the point $(h_i(x), k)$, where $i = 1$ or 2 , and j and k are positive integers $\leq n$. We can carry out this identification of circles in pairs in many different ways, so long as we obtain a space \tilde{S} which is connected. For example, in the case where $n = 3$, we could carry out the identifications according to the following scheme: Identify

$$C'_1 \times \{1\} \quad \text{with} \quad C''_1 \times \{2\},$$

$$C'_1 \times \{2\} \quad \text{with} \quad C''_1 \times \{3\},$$

$$C'_1 \times \{3\} \quad \text{with} \quad C''_1 \times \{1\},$$

$$C'_2 \times \{1\} \quad \text{with} \quad C''_2 \times \{2\},$$

$$C'_2 \times \{2\} \quad \text{with} \quad C''_2 \times \{1\},$$

$$C'_2 \times \{3\} \quad \text{with} \quad C''_2 \times \{3\}.$$

We leave it to the reader to concoct other examples and to prove that in each case we actually obtain a covering space. Obviously, we could use a similar procedure to obtain examples of covering spaces of surfaces of higher genus.

2.7. Let X be a subset of the plane consisting of two circles tangent at a point:

$$C_1 = \{(x, y) : (x - 1)^2 + y^2 = 1\},$$

$$C_2 = \{(x, y) : (x + 1)^2 + y^2 = 1\},$$

$$X = C_1 \cup C_2.$$

We shall give two different examples of covering spaces of X . For the first example, let \tilde{X} denote the set of all points $(x, y) \in \mathbf{R}^2$ such that x or y (or both) is an integer; \tilde{X} is a union of horizontal and vertical straight lines. Define $p : \tilde{X} \rightarrow X$ by the formula

$$p(x, y) = \begin{cases} (1 + \cos(\pi - 2\pi x), \sin 2\pi x) & \text{if } y \text{ is an integer,} \\ (-1 + \cos 2\pi y, \sin 2\pi y) & \text{if } x \text{ is an integer.} \end{cases}$$

The map p wraps each horizontal line around the circle C_1 and each vertical line around the circle C_2 .

For the second example, let D_n denote the circle $\{(x, y) \in \mathbf{R}^2 : (x - 1)^2 + (y - 3n)^2 = 1\}$ for any integer n , positive, negative, or zero, and let L denote the vertical line $\{(x, y) : x = 0\}$. The circles D_n are pairwise disjoint, and each is tangent to the line L . Define

$$\tilde{X}' = L \cup \left(\bigcup_{n \in \mathbf{Z}} D_n \right),$$

and $p' : \tilde{X}' \rightarrow X$ as follows: Let p' map each circle D_n homeomorphically onto

C_1 by a vertical translation of the proper amount. Let p' wrap the line L around the circle C_2 in accordance with the formula

$$p'(0, y) = \left(-1 + \cos \frac{2\pi y}{3}, \sin \frac{2\pi y}{3} \right).$$

Then, (\tilde{X}', p') is a covering space of X .

2.8. Here is an example for students who have at least a slight familiarity with the theory of functions of a complex variable. As usual, let

$$\exp(z) = \sum_{n=0}^{\infty} \frac{z^n}{n!}$$

denote the exponential function, where z is any complex number. The exponential function is a map, $\exp: \mathbf{C} \rightarrow \mathbf{C} - \{0\}$, where \mathbf{C} denotes the complex plane. We assert that (\mathbf{C}, \exp) is a covering space of $\mathbf{C} - \{0\}$, and that, for any $z \in \mathbf{C} - \{0\}$, the open disc

$$U_z = \{w \in \mathbf{C} : |w - z| < |z|\}$$

is an elementary neighborhood. To prove this, we would have to show that any component V of the inverse image of U_z is mapped homeomorphically onto U_z by \exp ; i.e., that there exists a continuous function $f: U_z \rightarrow V$ such that, for any $w \in U_z$,

$$\exp[f(w)] = w,$$

and, for any $v \in V$,

$$f(\exp v) = v.$$

Such a function f is called a “branch of the logarithm function in the disc U_z ” in books on complex variables, and in the course of establishing the properties of the logarithm, the required facts are proved.

Recall that, if $z = x + iy$, then $\exp z = (\exp x) \cdot (\cos y + i \sin y)$, where $\exp x = e^x$ now refers to the more familiar real exponential function, $\exp: \mathbf{R} \rightarrow \{t \in \mathbf{R} : t > 0\}$. From this formula, the following fact emerges. We can regard $\mathbf{C} = \mathbf{R} \times \mathbf{R}$ and $\mathbf{C} - \{0\} = \{r \in \mathbf{R} : r > 0\} \times S^1$ (use polar coordinates). Then, we can consider the map $\exp: \mathbf{C} \rightarrow \mathbf{C} - \{0\}$ as a map $p \times q: \mathbf{R} \times \mathbf{R} \rightarrow \{r \in \mathbf{R} : r > 0\} \times S^1$, where $p(x) = e^x$ and $q(y) = (\cos y, \sin y)$. Compare Examples 2.1, 2.3, and 2.4.

2.9. We now give another example from the theory of functions of a complex variable. For any integer $n \neq 0$, let $p_n: \mathbf{C} \rightarrow \mathbf{C}$ be defined by $p_n(z) = z^n$. Then, $(\mathbf{C} - \{0\}, p_n)$ is a covering space of $\mathbf{C} - \{0\}$. The proof is given in books on complex variables when the existence and properties of the various “branches” of the function $\sqrt[n]{z}$ are discussed; the situation is analogous to that in Example 2.8. Note that it is necessary to omit 0 from the domain and range of the function p_n ; otherwise we would not have a covering space. As in Example 2.8, we can consider $\mathbf{C} - \{0\} = \{r \in \mathbf{R} : r > 0\} \times S^1$ and decompose the covering space $(\mathbf{C} - \{0\}, p_n)$ into the Cartesian product of two covering spaces.

To clarify further the concept of covering space, we shall give some examples which are almost, but not quite, covering spaces.

Definition. A continuous map $f: X \rightarrow Y$ is a *local homeomorphism* if each point $x \in X$ has an open neighborhood V such that $f(V)$ is open and f maps V topologically onto $f(V)$.

It is readily proved that, if (\tilde{X}, p) is a covering space of X , then p is a local homeomorphism (the proof depends on the fact that in a locally arcwise connected space, the arc components of an open set are open). Also, the inclusion map of an open subset of a topological space into the whole space is a local homeomorphism. Finally, the composition of two local homeomorphisms is again a local homeomorphism. Thus, we can construct many examples of local homeomorphisms.

On the other hand, it is easy to construct examples of local homeomorphisms which are onto maps, but not covering spaces. For example, let p map the open interval $(0, 10)$ onto the circle S^1 as follows:

$$p(t) = (\cos t, \sin t).$$

Then, p is a local homeomorphism, but $((0, 10), p)$ is not a covering space of S^1 . (Which points of S^1 fail to have an elementary neighborhood?) More generally, if (\tilde{X}, p) is a covering space of X , and V is a connected, open, proper subset of \tilde{X} , then $p|_V$ is a local homeomorphism, but $(V, p|_V)$ is not a covering space of X . It is important to keep this distinction between covering spaces and local homeomorphisms in mind.

Note that a local homeomorphism is an open map. In particular, if (\tilde{X}, p) is a covering space of X , then p is an open map.

We next give a lemma which makes it possible to give many additional examples of covering spaces.

Lemma 2.1. *Let (\tilde{X}, p) be a covering space of X , let A be a subspace of X which is arcwise connected and locally arcwise connected, and let \tilde{A} be an arc component of $p^{-1}(A)$. Then, $(\tilde{A}, p|_{\tilde{A}})$ is a covering space of A .*

The proof is immediate. The two covering spaces described in Example 2.7 can also be obtained by applying this lemma to the covering spaces $\mathbf{R}^2 = \mathbf{R} \times \mathbf{R}$ and $\mathbf{R} \times S^1$ of the torus $S^1 \times S^1$ described in Example 2.4 [choose A to be the following subset of $S^1 \times S^1$: $A = (S^1 \times \{x_0\}) \cup (\{x_0\} \times S^1)$, where $x_0 \in S^1$].

We close this section by stating two of the principal problems in the theory of covering spaces:

- (a) Give necessary and sufficient conditions for two covering spaces (\tilde{X}_1, p_1) and (\tilde{X}_2, p_2) of X to be isomorphic (by definition, they are

isomorphic if and only if there exists a homeomorphism h of \tilde{X}_1 onto \tilde{X}_2 such that $p_2 h = p_1$).

- (b) Given a space X , determine all possible covering spaces of X (up to isomorphism).

As we shall see, these problems have reasonable answers in terms of the fundamental groups of the spaces involved.

EXERCISES

- 2.1. Prove that the following four conditions on a topological space are equivalent:

- (a) They are components of any open subset are open.
- (b) Every point has a basic family of arcwise-connected open neighborhoods.
- (c) Every point has a basic family of arcwise-connected neighborhoods (they are not assumed to be open).
- (d) For every point x and every neighborhood U of x , there exists a neighborhood V of x such that $V \subset U$ and any two points of V can be joined by an arc in U .

Thus, any one of these conditions could be taken as the definition of local arcwise connectivity.

- 2.2. Give an example of a local homeomorphism $f : X \rightarrow Y$ and a subset $A \subset X$ such that $f|_A$ is not a local homeomorphism of A onto $f(A)$.
- 2.3. Prove that if X is compact and $f : X \rightarrow Y$ is a local homeomorphism, then, for any point $y \in Y$, $f^{-1}(y)$ is a finite set. If it is also assumed that Y is a connected Hausdorff space, then f maps X onto Y .
- 2.4. Assume X and Y are arcwise connected and locally arcwise connected, X is compact Hausdorff, and Y is Hausdorff. Let $f : X \rightarrow Y$ be a local homeomorphism; prove that (X, f) is a covering space of Y . (WARNING: This exercise is more subtle than it looks!)

§3. Lifting of Paths to a Covering Space

In this section, we prove some simple lemmas which provide the key to many of the results in this chapter. Let (\tilde{X}, p) be a covering space of X , and let $g : I \rightarrow \tilde{X}$ be a path in \tilde{X} ; then, pg is a path in X . Also, if $g_0, g_1 : I \rightarrow \tilde{X}$ and $g_0 \sim g_1$, then $pg_0 \sim pg_1$. We can now ask for a sort of converse result: If $f : I \rightarrow X$ is a path in X , does there exist a path $g : I \rightarrow \tilde{X}$ such that $pg = f$? If $g_0, g_1 : I \rightarrow \tilde{X}$ and $pg_0 \sim pg_1$, does it follow that $g_0 \sim g_1$? We shall see that the answer to both questions is *Yes*. This fact expresses one of the basic properties of covering spaces.

Lemma 3.1. *Let (\tilde{X}, p) be a covering space of X , $\tilde{x}_0 \in \tilde{X}$, and $x_0 = p(\tilde{x}_0)$. Then, for any path $f : I \rightarrow X$ with initial point x_0 , there exists a unique path $g : I \rightarrow \tilde{X}$ with initial point \tilde{x}_0 such that $pg = f$.*

PROOF. If the path f were contained in an elementary neighborhood U there would be no problem. For, if V denotes the arc component of $p^{-1}(U)$ which contains \tilde{x}_0 , then, because p maps V topologically onto U , there would exist a unique g in V with the required properties.

Of course, f will not, in general, be contained in an elementary neighborhood U . However, we can always express f as the product of a finite number of "shorter" paths, each of which is contained in an elementary neighborhood, and then apply the argument in the preceding paragraph to each of these shorter paths in succession.

The details of this procedure may be described as follows. Let $\{U_i\}$ be a covering of X by elementary neighborhoods; then $\{f^{-1}(U_i)\}$ is an open covering of the compact metric space I . Choose an integer n so large that $1/n$ is less than the Lebesgue number of this covering. Divide the interval I into the closed subintervals $[0, 1/n]$, $[1/n, 2/n]$, \dots , $[(n-1)/n, 1]$. Note that f maps each subinterval into an elementary neighborhood in X . We now define g successively over these subintervals, starting with $[0, 1/n]$.

The uniqueness of the lifted path g is a consequence of the following more general lemma.

Lemma 3.2. *Let (\tilde{X}, p) be a covering space of X and let Y be a space which is connected. Given any two continuous maps $f_0, f_1 : Y \rightarrow \tilde{X}$ such that $pf_0 = pf_1$, the set $\{y \in Y : f_0(y) = f_1(y)\}$ is either empty or all of Y .*

PROOF. Because Y is connected, it suffices to prove that the set in question is both open and closed. First we shall prove that it is closed. Let y be a point of the closure of this set, and let

$$x = pf_0(y) = pf_1(y).$$

Assume $f_0(y) \neq f_1(y)$; we will show that this assumption leads to a contradiction. Let U be an elementary neighborhood of x , and let V_0 and V_1 be the components of $p^{-1}(U)$ which contain $f_0(y)$ and $f_1(y)$, respectively. Since f_0 and f_1 are both continuous, we can find a neighborhood W of y such that $f_0(W) \subset V_0$ and $f_1(W) \subset V_1$. But it is readily seen that this contradicts the fact that any neighborhood W of y must meet the set in question.

An analogous argument enables us to show that every point of the set $\{y \in Y : f_0(y) = f_1(y)\}$ is an interior point. Q.E.D.

Lemma 3.3. *Let (\tilde{X}, p) be a covering space of X and let $g_0, g_1 : I \rightarrow \tilde{X}$ be paths in \tilde{X} which have the same initial point. If $pg_0 \sim pg_1$, then $g_0 \sim g_1$; in particular, g_0 and g_1 have the same terminal point.*

PROOF. The strategy of this proof is essentially the same as that of Lemma 3.1. Let \tilde{x}_0 be the initial point of g_0 and g_1 . The hypothesis $pg_0 \sim pg_1$ implies the existence of a map $F : I \times I \rightarrow X$ such that

$$\begin{aligned}
 F(s, 0) &= pg_0(s), \\
 F(s, 1) &= pg_1(s), \\
 F(0, t) &= pg_0(0) = p(\tilde{x}_0), \\
 F(1, t) &= pg_0(1).
 \end{aligned}$$

By an argument using the Lebesgue number, etc., we can find numbers $0 = s_0 < s_1 < \dots < s_m = 1$ and $0 = t_0 < t_1 < \dots < t_n = 1$ such that F maps each small rectangle $[s_{i-1}, s_i] \times [t_{j-1}, t_j]$ into some elementary neighborhood in X . We shall prove that there exists a unique map $G : I \times I \rightarrow \tilde{X}$ such that $pG = F$ and $G(0, 0) = \tilde{x}_0$. First, we define G over the small rectangle $[0, s_1] \times [0, t_1]$ so that the required properties hold; it is clear that this can be done because F maps this small rectangle into an elementary neighborhood of the point $p(\tilde{x}_0)$. Then, we extend the definition of G successively over the rectangles $[s_{i-1}, s_i] \times [0, t_1]$ for $i = 2, 3, \dots, m$, taking care that the definitions agree on the common edge of any two successive rectangles. Thus, G is defined over the strip $I \times [0, t_1]$. Next, G is defined over the rectangles in the strip $I \times [t_1, t_2]$, etc.

The uniqueness of G is assured by Lemma 3.2. Similarly, by the uniqueness assertion of Lemma 3.1, we see that $G(s, 0) = g_0(s)$, $G(0, t) = \tilde{x}_0$, $G(s, 1) = g_1(s)$, and that G maps $\{1\} \times I$ into a single point \tilde{x}_1 such that

$$p(\tilde{x}_1) = pg_0(1) = pg_1(1).$$

Thus, G defines an equivalence between the paths g_0 and g_1 as required. Q.E.D.

As a corollary to these results on the lifting of paths, we shall prove the following lemma:

Lemma 3.4. *If (\tilde{X}, p) is a covering space of X , then the sets $p^{-1}(x)$ for all $x \in X$ have the same cardinal number.*

PROOF. Let x_0 and x_1 be any two points of X . Choose a path f in X with initial point x_0 and terminal point x_1 . Using the path f , we can define a mapping $p^{-1}(x_0) \rightarrow p^{-1}(x_1)$ by the following procedure. Given any point $y_0 \in p^{-1}(x_0)$, lift f to a path g in \tilde{X} with initial point y_0 such that $pg = f$. Let y_1 denote the terminal point of g . Then, $y_0 \rightarrow y_1$ is the desired mapping. Using the inverse path \bar{f} [defined by $\bar{f}(t) = f(1 - t)$], we can define in an analogous way a map $p^{-1}(x_1) \rightarrow p^{-1}(x_0)$. It is clear that these maps are the inverse of each other; hence each is one-to-one and onto. Q.E.D.

This common cardinal number of the sets $p^{-1}(x)$, $x \in X$, is called the *number of sheets* of the covering space (\tilde{X}, p) . For example, we speak of an n -sheeted covering, or an infinite-sheeted covering.

Examples

3.1. Consider the covering space (\mathbf{R}, p) of S^1 described in Example 2.1. According to Lemmas 3.1 and 3.3, any element $\alpha \in \pi(S^1, (0, 1))$ can be “lifted” to a *unique* path class in \mathbf{R} starting at the point 0. The end point of this path class will be some integral multiple of 2π . Conversely, suppose we have a path class β in \mathbf{R} starting at 0 and ending at some point which is an integral multiple of 2π . The path class $p_*(\beta)$ is an element of $\pi(S^1)$. According to this argument, path classes in \mathbf{R} which end at different integral multiples of 2π must give rise to different elements of $\pi(S^1)$. Thus, $\pi(S^1)$ is an infinite group. This completes the proof of Theorem 5.1 of Chapter II.

§4. The Fundamental Group of a Covering Space

As a corollary of Lemma 3.3, we have the following fundamental result:

Theorem 4.1. *Let (\tilde{X}, p) be a covering space of X , $\tilde{x}_0 \in \tilde{X}$, and $x_0 = p(\tilde{x}_0)$. Then, the induced homomorphism $p_* : \pi(\tilde{X}, \tilde{x}_0) \rightarrow \pi(X, x_0)$ is a monomorphism.*

This is a direct consequence of the special case of Lemma 3.3 in which g_0 and g_1 are assumed to be *closed* paths.

This theorem leads to the following question: Suppose \tilde{x}_0 and \tilde{x}_1 are points of \tilde{X} such that $p(\tilde{x}_0) = p(\tilde{x}_1) = x_0$. How do the images of the homomorphisms

$$p_* : \pi(\tilde{X}, \tilde{x}_0) \rightarrow \pi(X, x_0),$$

$$p_* : \pi(\tilde{X}, \tilde{x}_1) \rightarrow \pi(X, x_0),$$

compare? The answer is very simple. Choose a class γ of paths in \tilde{X} from \tilde{x}_0 to \tilde{x}_1 ; this defines an isomorphism $u : \pi(\tilde{X}, \tilde{x}_0) \rightarrow \pi(\tilde{X}, \tilde{x}_1)$ by the formula $u(\alpha) = \gamma^{-1}\alpha\gamma$. Thus, we obtain the following commutative diagram (see the exercises in §II.4):

$$\begin{array}{ccc} \pi(\tilde{X}, \tilde{x}_0) & \xrightarrow{p_*} & \pi(X, x_0) \\ \downarrow u & & \downarrow v \\ \pi(\tilde{X}, \tilde{x}_1) & \xrightarrow{p_*} & \pi(X, x_0) \end{array}$$

Here, $v(\beta) = (p_*\gamma)^{-1}\beta(p_*\gamma)$. But $p_*(\gamma)$ is a closed path, and, hence, an element of $\pi(X, x_0)$. Thus, we see that the *images of $\pi(\tilde{X}, \tilde{x}_0)$ and of $\pi(\tilde{X}, \tilde{x}_1)$ under p_* are conjugate subgroups of $\pi(X, x_0)$.*

Next, the question arises, can *every* subgroup in the conjugacy class of the subgroup $p_*\pi(\tilde{X}, \tilde{x}_0)$ be obtained as the image $p_*\pi(\tilde{X}, \tilde{x}_1)$ for some choice of the point $\tilde{x}_1 \in p^{-1}(x_0)$? Here the answer is *Yes*. To prove this, note that any subgroup in this conjugacy class is of the form $\alpha^{-1}[p_*\pi(\tilde{X}, \tilde{x}_0)]\alpha$ for some

choice of the element $\alpha \in \pi(X, x_0)$. Choose a closed path $f : I \rightarrow X$ representing α . Apply Lemma 3.1 to obtain a path $g : I \rightarrow \tilde{X}$ covering α with initial point \tilde{x}_0 . Let \tilde{x}_1 be the terminal point of this lifted path. Then, it is readily seen that

$$p_*\pi(\tilde{X}, \tilde{x}_1) = \alpha^{-1}[p_*\pi(\tilde{X}, \tilde{x}_0)]\alpha.$$

We can summarize what we have proved in the following theorem:

Theorem 4.2. *Let (\tilde{X}, p) be a covering space of X and $x_0 \in X$. Then, the subgroups $p_*\pi(\tilde{X}, \tilde{x})$ for $\tilde{x} \in p^{-1}(x_0)$ are exactly a conjugacy class of subgroups of $\pi(X, x_0)$.*

The student who desires examples of this theorem can consider the various examples of covering spaces given in §2.

EXERCISES

4.1. Discuss the effect of the changing the “base point” x_0 in the statement of Theorem 4.2 to a new base point $x_1 \in X$.

This conjugacy class of subgroups of $\pi(X, x_0)$ is an algebraic invariant of the covering space (\tilde{X}, p) . We shall later prove that it completely determines the covering space up to isomorphism!

§5. Lifting of Arbitrary Maps to a Covering Space

In §3 we studied the “lifting” of paths in X to a covering space \tilde{X} . We now study the analogous problem for maps of any space Y into X . To discuss this question, we introduce the following notation: If X and Y are topological spaces, $x \in X$ and $y \in Y$, then the notation $f : (X, x) \rightarrow (Y, y)$ means f is a continuous map of X into Y and $f(x) = y$. With this notation, we can concisely state our main question as follows: Let (\tilde{X}, p) be a covering space of X , $\tilde{x}_0 \in \tilde{X}$, $x_0 = p(\tilde{x}_0)$, $y_0 \in Y$, and $\varphi : (Y, y_0) \rightarrow (X, x_0)$. Under what conditions does there exist a map $\tilde{\varphi} : (Y, y_0) \rightarrow (\tilde{X}, \tilde{x}_0)$ such that the diagram

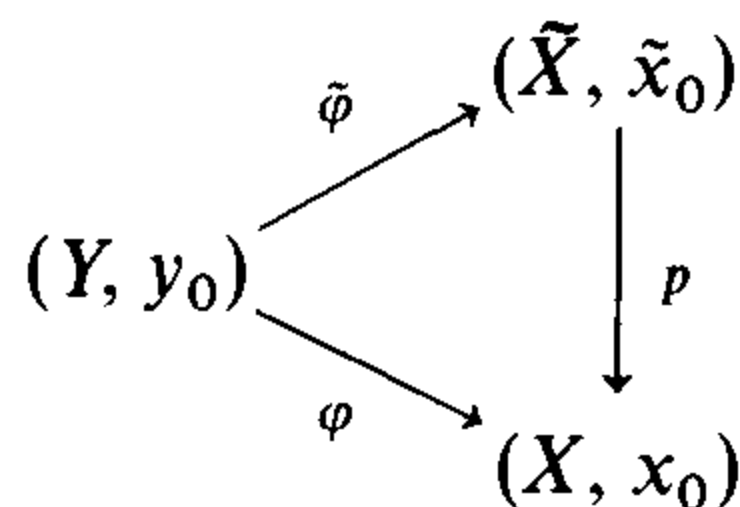

is commutative? If such a map $\tilde{\varphi}$ exists, we say that φ can be *lifted* to $\tilde{\varphi}$, or that $\tilde{\varphi}$ is a *lifting* of φ .

It is easy to obtain a necessary condition for the existence of such a lifting $\tilde{\varphi}$ by consideration of the fundamental groups of the spaces involved. For, if

we assume such a map $\tilde{\varphi}$ exists, then we obtain the following commutative diagram of groups and homomorphisms:

$$\begin{array}{ccc}
 & & (\tilde{X}, \tilde{x}_0) \\
 & \nearrow \tilde{\varphi}_* & \downarrow p_* \\
 \pi(Y, y_0) & & \pi(X, x_0) \\
 & \searrow \varphi_* &
 \end{array}$$

Because p_* is a monomorphism, the existence of a homomorphism $\tilde{\varphi}_* : \pi(Y, y_0) \rightarrow \pi(\tilde{X}, \tilde{x}_0)$, which makes this diagram commutative, is exactly equivalent to the condition that the image of φ_* be contained in the image of p_* . This is our desired necessary condition. The surprising thing is that this necessary condition is also sufficient.

Theorem 5.1. *Let (\tilde{X}, p) be a covering space of X , Y a connected and locally arcwise-connected space, $y_0 \in Y$, $\tilde{x}_0 \in \tilde{X}$, and $x_0 = p(\tilde{x}_0)$. Given a map $\varphi : (Y, y_0) \rightarrow (X, x_0)$, there exists a lifting $\tilde{\varphi} : (Y, y_0) \rightarrow (\tilde{X}, \tilde{x}_0)$ if and only if $\varphi_* \pi(Y, y_0) \subset p_* \pi(\tilde{X}, \tilde{x}_0)$.*

PROOF. We have already proved the necessity of the given condition; it remains to prove it is sufficient. To do this, we must actually define the map $\tilde{\varphi}$. The following considerations show that there is an essentially unique way to define $\tilde{\varphi}$ if it exists at all. Assume that $\tilde{\varphi}$ exists; let y be any point of Y . Because Y is arcwise connected, we may choose a path $f : I \rightarrow Y$ with initial point y_0 and terminal point y . Consider the paths φf and $\tilde{\varphi} f$ in X and \tilde{X} , respectively. The path $\tilde{\varphi} f$ is a lifting of the path φf , and $\tilde{\varphi}(y)$ is the terminal point of the path $\tilde{\varphi} f$.

In view of these considerations, we *define* the map $\tilde{\varphi} : (Y, y_0) \rightarrow (\tilde{X}, \tilde{x}_0)$ as follows: Given any point $y \in Y$, choose a path $f : I \rightarrow Y$ with initial point y_0 and terminal point y . Then, φf is a path in X with initial point x_0 . Apply Lemma 3.12 to obtain a path $g : I \rightarrow \tilde{X}$ such that the initial point of g is \tilde{x}_0 and $pg = \varphi f$. Define

$$\tilde{\varphi}(y) = \text{terminal point of } g.$$

To justify this definition, we must show that $\tilde{\varphi}(y)$ is independent of the choice of the path f . By using Lemma 3.3, we see that we can replace f by an equivalent path without altering the definition of $\tilde{\varphi}(y)$; i.e., $\tilde{\varphi}(y)$ only depends on the equivalence class α of the path f . Suppose that α and β are two different equivalence classes of paths in Y from y_0 to y . Then, $\alpha\beta^{-1}$ is a closed path based at y_0 ; hence, $\alpha\beta^{-1} \in \pi(Y, y_0)$ and therefore by the hypothesis of the theorem, $\varphi_*(\alpha\beta^{-1}) \in p_* \pi(\tilde{X}, \tilde{x}_0)$. Thus, there is a class of loops based at \tilde{x}_0 in \tilde{X} which projects onto $(\varphi_*\alpha)(\varphi_*\beta)^{-1}$, or, if $(\varphi_*\alpha)(\varphi_*\beta)^{-1}$ is "lifted" to a path in \tilde{X} starting at \tilde{x}_0 , the result is a closed path in \tilde{X} . Hence, if $\varphi_*\alpha$ and $\varphi_*\beta$ are each lifted to paths in \tilde{X} starting at \tilde{x}_0 , they have the same terminal point.

Next, we must prove that the function $\tilde{\varphi}$ thus defined is continuous. Let $y \in Y$ and let U be an arbitrary neighborhood of $\tilde{\varphi}(y)$. We must show that there exists a neighborhood V of y such that $\tilde{\varphi}(V) \subset U$. Choose an elementary neighborhood U' of $p\tilde{\varphi}(y) = \varphi(y)$ such that $U' \subset p(U)$. Let W be the arc component of $p^{-1}(U')$ which contains $\tilde{\varphi}(y)$, and let U'' be an elementary neighborhood of $\varphi(y)$ such that $U'' \subset p(U \cap W)$. Then it is easily shown that the arc component of $p^{-1}(U'')$, which contains $\tilde{\varphi}(y)$ is contained in U . Because φ is continuous, we can choose V such that $\varphi(V) \subset U''$. We can also choose V so that it is arcwise connected, because Y is locally arcwise connected. We leave it to the reader to verify that the neighborhood V thus chosen has the required properties.

It is obvious from our method of defining $\tilde{\varphi}$ that the required commutativity relation $p\tilde{\varphi} = \varphi$ holds. Q.E.D.

Remarks: 1. The map $\tilde{\varphi}$ is unique, in view of Lemma 3.2. The uniqueness of $\tilde{\varphi}$ is also clear from the proof of the theorem.

2. This theorem is a beautiful illustration of the general strategy of algebraic topology: A purely topological question (the existence of a continuous map satisfying certain conditions) is reduced to a purely algebraic question. In most cases in algebraic topology where such a reduction can be effected, the details are much more complicated than in Theorem 5.1.

EXERCISES

- 5.1.** Let G be a topological space with a continuous multiplication $\mu: G \times G \rightarrow G$ with a unit e such that $\mu(e, x) = \mu(x, e) = x$ for any $x \in X$ (see Exercise II.7.5). Let (\tilde{G}, p) be a covering space of G and $\tilde{e} \in \tilde{G}$ a point such that $p(\tilde{e}) = e$. Prove that there exists a unique continuous multiplication $\tilde{\mu}: \tilde{G} \times \tilde{G} \rightarrow \tilde{G}$ such that \tilde{e} is a unit [i.e., $\tilde{\mu}(\tilde{e}, y) = \tilde{\mu}(y, \tilde{e}) = y$ for any $y \in \tilde{G}$] and p commutes with the multiplication in \tilde{G} and G [i.e., $\mu(px, py) = p\tilde{\mu}(x, y)$]. (HINT: Use Theorem 5.1 together with the result of Example 2.4 and the exercise of §II.7 referred to above.) Assume G is arcwise connected and locally arcwise connected as usual. Prove also that, if the multiplication μ is associative, then so is the multiplication $\tilde{\mu}$.
- 5.2.** Let G be a connected, locally arcwise-connected topological group with unit e . Let (\tilde{G}, p) be a covering space of G and $\tilde{e} \in \tilde{G}$ such that $p(\tilde{e}) = e$. Prove that there exists a unique continuous multiplication $\mu: \tilde{G} \times \tilde{G} \rightarrow \tilde{G}$ such that \tilde{G} is a topological group with unit \tilde{e} and p is a homomorphism. (HINT: Use the results of Exercises 5.1 and II.7.6 to show the existence of inverses in \tilde{G} .) Prove also that the kernel of p is a discrete normal subgroup of \tilde{G} and hence is contained in the center of \tilde{G} .
- 5.3.** Apply the considerations of Exercise 5.2 to the case in which $G = S^1$, the multiplicative group of all complex numbers of absolute value 1. Examples of covering spaces of S^1 were described in §2.
- 5.4.** In Exercises 5.1 and 5.2, if the multiplication in G is commutative, prove that the multiplication in \tilde{G} is also commutative.

§6. Homomorphisms and Automorphisms of Covering Spaces

We wish to obtain some information about the various possible covering spaces of a given space X . As we shall see, we can gain much insight into this problem by considering homomorphisms and automorphisms of covering spaces of X . This procedure is in accordance with the following semimystical principle which seems to help guide much present-day mathematical research: Whenever we wish to gain information about a certain class of mathematical objects, it is usually helpful to consider also the appropriate class of admissible maps and automorphisms of these objects.

Definition. Let (\tilde{X}_1, p_1) and (\tilde{X}_2, p_2) be covering spaces of X . A *homomorphism* of (\tilde{X}_1, p_1) into (\tilde{X}_2, p_2) is a continuous map $\varphi: \tilde{X}_1 \rightarrow \tilde{X}_2$ such that the following diagram is commutative:

$$\begin{array}{ccc} \tilde{X}_1 & \xrightarrow{\varphi} & \tilde{X}_2 \\ & \searrow p_1 & \swarrow p_2 \\ & X & \end{array}$$

Note that the composition of two homomorphisms is again a homomorphism, and that, if (\tilde{X}, p) is a covering space of X , then the identity map $\tilde{X} \rightarrow \tilde{X}$ is a homomorphism.

Definition. A homomorphism φ of (\tilde{X}_1, p_1) into (\tilde{X}_2, p_2) is called an *isomorphism* if there exists a homomorphism ψ of (\tilde{X}_2, p_2) into (\tilde{X}_1, p_1) such that both compositions $\psi\varphi$ and $\varphi\psi$ are identity maps. Two covering spaces are said to be *isomorphic* if there exists an isomorphism of one onto the other. An *automorphism* is an isomorphism of a covering space onto itself; it may or may not be the identity map.

Automorphisms of covering spaces are usually called *covering transformations* in the literature (German: *Deckbewegung*). Note that a homomorphism of covering spaces is an isomorphism if and only if it is a homeomorphism in the usual sense. The set of all automorphisms of a covering space (\tilde{X}, p) of X is obviously a group under the operation of composing maps. We shall use the notation $A(\tilde{X}, p)$ to denote this group.

We now derive some basic properties of homomorphisms and automorphisms of covering spaces.

Lemma 6.1. Let φ_0 and φ_1 be homomorphisms of (\tilde{X}_1, p_1) into (\tilde{X}_2, p_2) . If there exists any point $x \in \tilde{X}_1$ such that $\varphi_0(x) = \varphi_1(x)$, then $\varphi_0 = \varphi_1$.

This is a special case of Lemma 3.2.

Corollary 6.2. *The group $A(\tilde{X}, p)$ operates without fixed points on the space \tilde{X} ; i.e., if $\varphi \in A(\tilde{X}, p)$ and $\varphi \neq 1$, then φ has no fixed points.*

Lemma 6.3. *Let (\tilde{X}_1, p_1) and (\tilde{X}_2, p_2) be covering spaces of X and $\tilde{x}_i \in \tilde{X}_i$, $i = 1, 2$, points such that $p_1(\tilde{x}_1) = p_2(\tilde{x}_2)$. Then, there exists a homomorphism φ of (\tilde{X}_1, p_1) into (\tilde{X}_2, p_2) such that $\varphi(\tilde{x}_1) = \tilde{x}_2$ if and only if $p_{1*}\pi(\tilde{X}_1, \tilde{x}_1) \subset p_{2*}\pi(\tilde{X}_2, \tilde{x}_2)$.*

This is a special case of Theorem 5.1.

Corollary 6.4. *Under the hypotheses of Lemma 6.3, there exists an isomorphism φ of (\tilde{X}_1, p_1) onto (\tilde{X}_2, p_2) such that $\varphi(\tilde{x}_1) = \tilde{x}_2$ if and only if $p_{1*}\pi(\tilde{X}_1, \tilde{x}_1) = p_{2*}\pi(\tilde{X}_2, \tilde{x}_2)$.*

This is a direct consequences of Lemma 6.3, the definition of an isomorphism, and Corollary 6.2.

Corollary 6.5. *Let (\tilde{X}, p) be a covering space of X and $\tilde{x}_1, \tilde{x}_2 \in p^{-1}(x_0)$, where $x_0 \in X$. There exists an automorphism $\varphi \in A(\tilde{X}, p)$ such that $\varphi(\tilde{x}_1) = \tilde{x}_2$ if and only if $p_*\pi(\tilde{X}, \tilde{x}_1) = p_*\pi(\tilde{X}, \tilde{x}_2)$.*

This is a special case of Corollary 6.4.

Theorem 6.6. *Two covering spaces (\tilde{X}_1, p_1) and (\tilde{X}_2, p_2) of X are isomorphic if and only if, for any two points $\tilde{x}_1 \in \tilde{X}_1$ and $\tilde{x}_2 \in \tilde{X}_2$ such that $p_1(\tilde{x}_1) = p_2(\tilde{x}_2) = x_0$, the subgroups $p_{1*}\pi(\tilde{X}_1, \tilde{x}_1)$ and $p_{2*}\pi(\tilde{X}_2, \tilde{x}_2)$ belong to the same conjugacy class in $\pi(X, x_0)$.*

PROOF. This follows directly from Corollary 6.4 and Theorem 4.2.

This theorem shows that the conjugacy class of subgroups mentioned in Theorem 4.2 completely determines a covering space up to isomorphism.

Lemma 6.7. *Let (\tilde{X}_1, p_1) and (\tilde{X}_2, p_2) be covering spaces of X , and let φ be a homomorphism of the first covering space into the second. Then, (\tilde{X}_1, φ) is a covering space of \tilde{X}_2 .*

PROOF. First, note that any point $x \in X$ has an open arcwise-connected neighborhood U which is an elementary neighborhood of x for both of the covering spaces simultaneously. We can obtain such a neighborhood by choosing open elementary neighborhoods U_1 and U_2 of x for the coverings (\tilde{X}_1, p_1) and (\tilde{X}_2, p_2) , respectively, and then let U be the arc component of $U_1 \cap U_2$ which contains x .

Next, we prove that φ maps \tilde{X}_1 onto \tilde{X}_2 . Let y be any point of \tilde{X}_2 ; we must show that there exists a point x of \tilde{X}_1 such that $\varphi(x) = y$. Choose a base point

$x_1 \in \tilde{X}_1$, and let $x_2 = \varphi(x_1)$, $x_0 = p_1(x_1) = p_2(x_2)$. Choose a path f in \tilde{X}_2 with initial point x_2 and terminal point y , and let $g = p_2 f$ be the image path in X . By Lemma 3.1, there exists a unique path h in \tilde{X}_1 with initial point x_1 and such that $p_1 h = g$. Let x be the terminal point of h . Then the paths φh and f both have the same initial point and $p_2 \varphi h = g = p_2 f$, hence $\varphi h = f$ by the uniqueness assertion of Lemma 3.1. Therefore, $\varphi(x) = y$, as required.

It should now be clear how to choose an elementary neighborhood of any point $z \in \tilde{X}_2$. Choose a neighborhood U of $x = p_2(z)$ which is elementary for both coverings, and let W be the component of $p_2^{-1}(U)$ which contains z . The proof that W has the required properties is easy. Q.E.D.

Let (\tilde{X}, p) be a covering space of X such that \tilde{X} is simply connected. If (\tilde{X}', p') is any other covering space of X , then, by Lemma 6.3, there exists a homomorphism φ of (\tilde{X}, p) onto (\tilde{X}', p') , and, by the lemma just proved, (\tilde{X}, φ) is a covering space of \tilde{X}' ; i.e., \tilde{X} can serve as a covering space of any covering space of X . For this reason a simply connected covering space, such as (\tilde{X}, p) , is called a *universal covering space*. By Theorem 6.6, any two universal covering spaces of X are isomorphic.

EXERCISES

- 6.1. Prove that, if X is a simply connected space and (\tilde{X}, p) is a covering space of X , then p is a homeomorphism of \tilde{X} onto X .
- 6.2. Determine all covering spaces (up to isomorphism) of each of the following spaces: S^1 , the circle; P , the projective plane; the subset $\{(x, y) \in \mathbf{R}^2 : 1 \leq x^2 + y^2 \leq 4\}$ of the plane. Exhibit an explicit covering space (\tilde{X}, p) from each isomorphism class. (SUGGESTION: Consider the examples in §2.)
- 6.3. Let X be a topological space whose fundamental group is abelian and which has a universal covering space. If (\tilde{X}_1, p_1) and (\tilde{X}_2, p_2) are covering spaces of X , define $(\tilde{X}_1, p_1) \cong (\tilde{X}_2, p_2)$ if and only if there exists a homomorphism of (\tilde{X}_1, p_1) onto (\tilde{X}_2, p_2) . Prove that this relation is transitive, reflexive, and, if $(\tilde{X}_1, p_1) \leq (\tilde{X}_2, p_2)$ and $(\tilde{X}_2, p_2) \leq (\tilde{X}_1, p_1)$, then (\tilde{X}_1, p_1) is isomorphic to (\tilde{X}_2, p_2) . Finally, prove that any two covering spaces of X have a least upper bound and a greatest lower bound with respect to this partial ordering relation. [NOTE: This result is definitely not true if the hypothesis that $\pi(X)$ is abelian is omitted.] (SUGGESTION: Use Lemma 10.1.)
- 6.4. Let

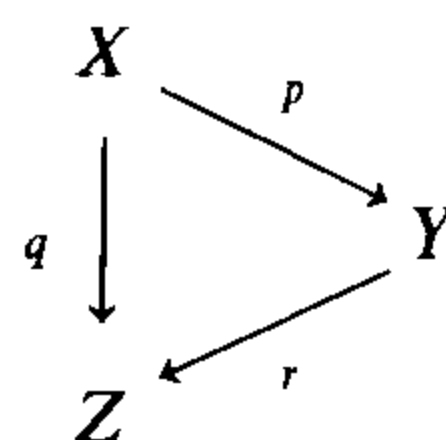

be a commutative diagram of spaces and continuous maps. Assume that (X, p) is a covering space of Y and (X, q) is a covering space of Z . Prove that (Y, r) is a

covering space of Z . [HINT: Let $U \subset Z$ be an elementary neighborhood for the covering space (X, q) , and let V be an arc component of $r^{-1}(U)$. Apply Lemma 2.1 to V considered as a subspace of Y .]

6.5. Let X be a space which has a universal covering space. If (X_1, p_1) is a covering space of X and (X_2, p_2) is a covering space of X_1 , then $(X_2, p_1 p_2)$ is a covering space of X .

§7. The Action of the Group $\pi(X, x)$ on the Set $p^{-1}(x)$

To study further the group of automorphisms of a covering space (\tilde{X}, p) of X , we define an action of the group $\pi(X, x)$ on the set $p^{-1}(x)$ for any $x \in X$; i.e., we make $\pi(X, x)$ operate on the right on the set $p^{-1}(x)$. The definition is very natural and simple; it depends on Lemmas 3.1 and 3.3. on the lifting of paths.

Definition. Let (\tilde{X}, p) be a covering space of X and $x \in X$. For any point $\tilde{x} \in p^{-1}(x)$ and any $\alpha \in \pi(X, x)$, define $\tilde{x} \cdot \alpha \in p^{-1}(x)$ as follows. By Lemmas 3.1 and 3.3, there exists a unique path class $\tilde{\alpha}$ in \tilde{X} such that $p_*(\tilde{\alpha}) = \alpha$ and the initial point of $\tilde{\alpha}$ is the point \tilde{x} . Define $\tilde{x} \cdot \alpha$ to be the terminal point of the path class $\tilde{\alpha}$.

We leave it to the reader to verify the formulas:

$$(\tilde{x} \cdot \alpha) \cdot \beta = \tilde{x} \cdot (\alpha \cdot \beta), \quad (5.7.1)$$

$$\tilde{x} \cdot 1 = \tilde{x}. \quad (5.7.2)$$

These are exactly the conditions needed for $\pi(X, x)$ to be a group of right operators on the set $p^{-1}(x)$ (see Appendix B). We assert that the group $\pi(X, x)$ operates *transitively* on the set $p^{-1}(x)$. To prove this, let \tilde{x}_0 and $\tilde{x}_1 \in p^{-1}(x)$; because \tilde{X} is assumed to be arcwise connected, there exists a path class $\tilde{\alpha}$ in \tilde{X} with initial point \tilde{x}_0 and terminal point \tilde{x}_1 . Let $\alpha = p_*(\tilde{\alpha})$. Then, α is an equivalence class of closed paths, and obviously $\tilde{x}_0 \cdot \alpha = \tilde{x}_1$ as was to be proved.

Thus, the set $p^{-1}(x)$ is a homogeneous right $\pi(X, x)$ -space (as defined in Appendix B). From the definition, we see immediately that, for any point $\tilde{x} \in p^{-1}(x)$, the isotropy subgroup corresponding to this point is precisely the subgroup $p_* \pi(\tilde{X}, \tilde{x})$ of $\pi(X, x)$. Hence, as a right $\pi(X, x)$ -space, $p^{-1}(x)$ is isomorphic to the space of cosets, $\pi(X, x) / p_* \pi(\tilde{X}, \tilde{x})$, and the number of sheets of the covering is equal to the index of the subgroup $p_* \pi(\tilde{X}, \tilde{x})$.

We now have the following important result, which establishes a connection between the group of automorphisms of a covering space and the action of $\pi(X, x)$ on $p^{-1}(x)$.

Proposition 7.1. For any automorphism $\varphi \in A(\tilde{X}, p)$, any point $\tilde{x} \in p^{-1}(x)$, and any $\alpha \in \pi(X, x)$,

$$\varphi(\tilde{x} \cdot \alpha) = (\varphi\tilde{x}) \cdot \alpha;$$

i.e., each element $\varphi \in A(\tilde{X}, p)$ induces an automorphism of the set $p^{-1}(x)$ considered as a right $\pi(X, x)$ -space.

PROOF. The proof is simple. Let α be a path in \tilde{X} with initial point \tilde{x} and such that $p_*(\tilde{\alpha}) = \alpha$; then $\tilde{x} \cdot \alpha$ is the terminal point of $\tilde{\alpha}$. Now consider the path $\varphi_*(\tilde{\alpha})$ in \tilde{X} . Its initial point is $\varphi(\tilde{x})$, and its terminal point is $\varphi(\tilde{x} \cdot \alpha)$. Next, observe that

$$p_*[\varphi_*(\tilde{\alpha})] = (p\varphi)_*(\tilde{\alpha}) = p_*(\tilde{\alpha}) = \alpha;$$

i.e., $\varphi_(\tilde{\alpha})$ is a lifting of the path α also. Hence, by definition $(\varphi\tilde{x}) \cdot \alpha$ is the terminal point of the path $\varphi_*(\tilde{\alpha})$; *i.e., $(\varphi\tilde{x}) \cdot \alpha = \varphi(\tilde{x} \cdot \alpha)$, as required.**

We can now completely determine the structure of the automorphism group $A(\tilde{X}, p)$.

Theorem 7.2. *Let (\tilde{X}, p) be a covering space of X . Then, the group of automorphisms, $A(\tilde{X}, p)$, is naturally isomorphic to the group of automorphisms of the set $p^{-1}(x)$, $x \in X$, considered as a right $\pi(X, x)$ -space.*

PROOF. If φ is any automorphism of (\tilde{X}, p) , then the restriction $\varphi|_{p^{-1}(x)}$ is an automorphism of $p^{-1}(x)$ as a right $\pi(X, x)$ -space, in view of Proposition 7.1. Moreover, it follows from Corollary 6.2 that each automorphism φ is completely determined by its restriction, $\varphi|_{p^{-1}(x)}$. In other words, the mapping $\varphi \rightarrow \varphi|_{p^{-1}(x)}$ is a monomorphism of $A(\tilde{X}, p)$ into the group of automorphisms of the right $\pi(X, x)$ -space $p^{-1}(x)$. Next, it follows from Lemma 2.1 of Appendix B and Corollary 6.5 that the mapping $\varphi \rightarrow \varphi|_{p^{-1}(x)}$ is an epimorphism of $A(\tilde{X}, p)$ onto the group of automorphisms of $p^{-1}(x)$. Hence, we have the theorem. Q.E.D.

Corollary 7.3. *For any point $x \in X$ and any $\tilde{x} \in p^{-1}(x)$, the automorphism group $A(\tilde{X}, p)$ is isomorphic to the quotient group $N[p_*\pi(\tilde{X}, \tilde{x})]/p_*\pi(\tilde{X}, \tilde{x})$, where $N[p_*\pi(\tilde{X}, \tilde{x})]$ denotes the normalizer of the subgroup $p_*\pi(\tilde{X}, \tilde{x})$ in $\pi(X, x)$.*

This corollary is obtained by applying Theorem 2.2 of Appendix B to Theorem 7.2.

An especially important class of covering spaces consists of those for which $p_*\pi(\tilde{X}, \tilde{x})$ is a *normal* subgroup of $\pi(X, x)$. [Note that this condition is independent of the choice of the point $\tilde{x} \in p^{-1}(x)$.] Such a covering space is called *regular*.

Corollary 7.4. *If (\tilde{X}, p) is a regular covering space of X , then $A(\tilde{X}, p)$ is isomorphic to the quotient group $\pi(X, x)/p_*\pi(\tilde{X}, \tilde{x})$ for any $x \in X$ and any $\tilde{x} \in p^{-1}(x)$.*

This follows from Corollary 7.3 because $N[p_*\pi(\tilde{X}, \tilde{x})] = \pi(X, x)$ in this case.

This corollary applies in particular to the universal covering space:

Corollary 7.5. *Let (\tilde{X}, p) be a universal covering space of X . Then, $A(\tilde{X}, p)$ is isomorphic to $\pi(X)$, and the order of the group $\pi(X)$ is equal to the number of sheets of the covering space (\tilde{X}, p) .*

Examples

7.1. Consider the covering space (\mathbf{R}, p) of the circle S^1 defined by $p(t) = (\sin t, \cos t)$ for any $t \in \mathbf{R}$ (see Example 2.1). Because the real line \mathbf{R} is contractible, it is simply connected. Therefore, (\mathbf{R}, p) is a universal covering space of S^1 , and Corollary 7.5 is applicable. Let us determine the group of automorphisms of this covering space. From the known periodicity of the functions $\sin t$ and $\cos t$, it is clear that the “translation” $T_n: \mathbf{R} \rightarrow \mathbf{R}$ defined by $T_n(t) = t + 2n\pi$ is an automorphism for any integer n . Moreover, it is clear that, if x is any point of S^1 and t_1 and t_2 are any two points of $p^{-1}(x)$, then there exists an integer n such that $T_n(t_1) = t_2$. It follows that every automorphism of the covering space (\mathbf{R}, p) is such a translation (see Lemma 6.1 and Corollary 6.2). Because the group of all such translations $\{T_n: n \in \mathbf{Z}\}$ is obviously infinite cyclic, we have once again proved that $\pi(S^1)$ is infinite cyclic.

7.2. Let $p: S^2 \rightarrow P$ denote the natural map of the 2-sphere onto its quotient space, the projective plane; then, (S^2, p) is a covering space of P (see Example 2.5), and, because S^2 is simply connected, it is a universal covering space. Because it is a 2-sheeted covering space, the fundamental group $\pi(P)$ and the automorphism group must both be of order 2. It is clear that the automorphism group is generated by the antipodal map $T: S^2 \rightarrow S^2$, $T(x, y, z) = (-x, -y, -z)$.

EXERCISES

- 7.1.** Let $p: \tilde{G} \rightarrow G$ be a continuous homomorphism of topological groups such that (\tilde{G}, p) is a covering space of G . (It is assumed, of course, that both G and \tilde{G} are connected and locally arcwise connected.) Let K denote the kernel of p ; then K is a discrete subgroup of \tilde{G} which is contained in the center (see the exercises in §5). For each element $k \in K$, define a map $\varphi_k: \tilde{G} \rightarrow \tilde{G}$ by $\varphi_k(x) = x \cdot k = k \cdot x$. Prove that the mapping $k \rightarrow \varphi_k$ is an isomorphism of K onto $A(\tilde{G}, p)$.
- 7.2.** Determine the group of automorphisms of the covering spaces described in Examples 2.2, 2.4, 2.7, 2.8, and 2.9.

§8. Regular Covering Spaces and Quotient Spaces

Let (\tilde{X}, p) be a covering space of X ; because p is an open map, X has the quotient topology induced by p . Thus, we can regard X as being obtained from \tilde{X} by a process of identifying certain points: For any point $x \in X$, all the

points of the set $p^{-1}(x)$ are to be identified to a single point. Recall that the automorphism group $A(\tilde{X}, p)$ permutes the points of the set $p^{-1}(x)$ among themselves. However, it is *not* true, in general, that the quotient space $\tilde{X}/A(\tilde{X}, p)$ is naturally homeomorphic to X , because there may exist distinct points $\tilde{x}_1, \tilde{x}_2 \in p^{-1}(x)$ such that there is no automorphism $\varphi \in A(\tilde{X}, p)$ for which $\varphi(\tilde{x}_1) = \tilde{x}_2$; in other words, the automorphism group $A(\tilde{X}, p)$ need not operate transitively on $p^{-1}(x)$. Indeed, we have the following lemma:

Lemma 8.1 *Let (\tilde{X}, p) be a covering space of X . The automorphism group $A(\tilde{X}, p)$ operates transitively on $p^{-1}(x)$, $x \in X$, if and only if (\tilde{X}, p) is a regular covering space of X .*

This is an immediate consequences of Theorem 4.2 and Corollary 6.5.

As a result, we see that if (\tilde{X}, p) is a regular covering space of X , then X is naturally homeomorphic to the quotient space $\tilde{X}/A(\tilde{X}, p)$. This leads to the following rather natural question: Let Y be a topological space, and let G be a group of homeomorphisms of Y . Let $p: Y \rightarrow Y/G$ denote the natural map of Y onto its quotient space. Under what conditions is (Y, p) a regular covering space of Y/G with $A(Y, p) = G$? First, it is clear that there are some necessary conditions which must be satisfied. For example, if (\tilde{X}, p) is a regular covering space of X , then $A(\tilde{X}, p)$ acts on \tilde{X} without fixed points (this is the content of Corollary 6.2). Also, the orbit of any point $\tilde{x} \in \tilde{X}$ under the action of the group $A(\tilde{X}, p)$ [i.e., the set of points $\{\varphi(\tilde{x}) : \varphi \in A(\tilde{X}, p)\}$] is a discrete, closed subset of \tilde{X} . In fact, the following even stronger condition holds: Every point $\tilde{x} \in \tilde{X}$ has a neighborhood U such that the sets $\varphi(U)$, $\varphi \in A(\tilde{X}, p)$, are pairwise disjoint (we can choose U to be a component of the inverse image of an appropriate elementary neighborhood in X). A group of homeomorphisms satisfying this condition is said to be *properly discontinuous*. Note that a properly discontinuous group of homeomorphisms is fixed point free. It turns out that these necessary conditions are also sufficient.

Proposition 8.2. *Let Y be a connected, locally arcwise-connected topological space and let G be a properly discontinuous group of homeomorphisms of Y . Let $p: Y \rightarrow Y/G$ denote the natural projection of Y onto its quotient space. Then, (Y, p) is a regular covering space of Y/G , and $G = A(Y, p)$.*

PROOF. Let $x \in Y/G$; we must show that x has an elementary neighborhood. Choose a point $y \in Y$ such that $p(y) = x$. By hypothesis, there exists a neighborhood N of y such that the sets $\varphi(N)$, $\varphi \in G$, are pairwise disjoint. Because Y is locally arcwise connected, there exists an open, arcwise-connected neighborhood V of y such that $V \subset N$. Let $U = p(V)$. We assert that U is an elementary neighborhood of x . Because p is an open map, U is an open set, and it is clearly arcwise connected. It is also clear that p maps V in a one-to-one, continuous fashion onto U ; and because p is an open map, it is a homeomorphism of V onto U . If W is any component of $p^{-1}(U)$ different from

V , then there exists a $\varphi \in G$ such that $W = \varphi(V)$. Because φ is a homeomorphism of V onto W , and $p = p\varphi$, it follows that p also maps W homeomorphically onto U . Thus, U is an elementary neighborhood of x , and (Y, p) is a covering space of Y/G . It is obvious that every $\varphi \in G$ is an automorphism of (Y, p) ; thus, $G \subset A(Y, p)$. The assumption that G is a *proper* subgroup of $A(Y, p)$ is readily seen to imply that $A(Y, p)$ has elements with fixed points. Hence, $G = A(Y, p)$. Finally, it follows from Lemma 8.1 that (Y, p) is a regular covering space of Y/G . Q.E.D.

We shall now give some simple examples of this theorem.

Examples

8.1. Let $Y = \mathbf{R}$, the real line, and, for each integer n , define $\varphi_n : \mathbf{R} \rightarrow \mathbf{R}$ by $\varphi_n(x) = x + n$. Let $G = \{\varphi_n : n \in \mathbf{Z}\}$. Then, G is a properly discontinuous group of homeomorphisms of \mathbf{R} ; indeed, for any $x \in \mathbf{R}$, if we let U be the open interval $(x - \frac{1}{3}, x + \frac{1}{3})$, then the neighborhoods $\varphi_n(U)$ are pairwise disjoint. Hence, by the proposition just proved, \mathbf{R} is a regular covering space of the quotient space \mathbf{R}/G . By standard theorems on quotient spaces, \mathbf{R}/G is homeomorphic to the quotient space of the closed unit interval $[0, 1]$ obtained by identifying the two end points of the interval. Thus, \mathbf{R}/G is a circle. Once again we have proved that the universal covering space of a circle is the real line, and that the group of automorphisms is infinite cyclic (see Example 7.1).

8.2. Let $Y = S^n$, the unit n -sphere in Euclidean $(n + 1)$ -space, and let $T : S^n \rightarrow S^n$ be the antipodal map defined by $T(x) = -x$ for any $x \in S^n$. Clearly, T^2 is the identity transformation; hence, T generates a group G of homeomorphisms of S^n , which is cyclic of order 2. It is obvious that G is a properly discontinuous group of homeomorphisms; therefore, S^n is a covering space of S^n/G , which is a real projective n -space. Because S^n is simply connected, it is a universal covering space, and the fundamental group of a real projective n -space is cyclic of order 2 (see Example 7.2 for the case where $n = 2$).

EXERCISES

- 8.1.** Let Y be a Hausdorff space and let G be a *finite* group of homeomorphisms of Y such that each element $\varphi \neq 1$ of G has no fixed points. Prove that G is a properly discontinuous group of homeomorphisms.
- 8.2.** Let Y be a topological group and let G be a discrete subgroup of Y . Prove that there exists a neighborhood U of the identity such that the sets $g \cdot U$ for $g \in G$ are pairwise disjoint (NOTE: $g \cdot U = \{g \cdot x : x \in U\}$). HINT: Choose a neighborhood V of the identity such that $V \cap G = \{1\}$. Then prove that there exists a neighborhood U of the identity such that $\{x \cdot y^{-1} : x, y \in U\} \subset V$.
- 8.3.** Let Y be a topological group and let G be a discrete subgroup. Let Y/G denote the space of cosets $\{G \cdot y : y \in Y\}$ with the quotient space topology, and $p : Y \rightarrow Y/G$ the natural projection. Prove that (Y, p) is a regular covering space of Y/G .

with $A(Y, p) = G$, where G operators on Y by multiplication on the left. (HINT: Use the result of Exercise 8.2 and Proposition 8.2.) Note that Example 8.1 is a special case of this exercise.

- 8.4.** Let X be a regular topological space, and (\tilde{X}, p) a covering space of X . Prove that for any compact set $C \subset \tilde{X}$, the set $\{\varphi \in A(\tilde{X}, p) : \varphi(C) \cap C \neq \emptyset\}$ is finite.
- 8.5.** Let Y be a locally compact Hausdorff space, and let G be a group of homeomorphisms of Y such that each element $\varphi \neq 1$ of G has no fixed points, and for any compact set $C \subset Y$, the set $\{\varphi \in G : \varphi(C) \cap C \neq \emptyset\}$ is finite. Prove that G is a properly discontinuous group of homeomorphisms, and that the quotient space Y/G is locally compact and Hausdorff.

§9. Application: The Borsuk–Ulam Theorem for the 2-Sphere

As usual, let S^n denote the unit n -sphere in \mathbf{R}^{n+1} :

$$S^n = \{x \in \mathbf{R}^{n+1} : |x| = 1\}.$$

For any positive integers m and n , let us agree to call a map $f : S^m \rightarrow S^n$ *antipode preserving* in case $f(-x) = -f(x)$ for any $x \in S^m$. The following well-known theorem, due to the Polish mathematicians K. Borsuk and S. Ulam, has many interesting consequences.

Theorem 9.1. *There does not exist any continuous, antipode-preserving map $f : S^n \rightarrow S^{n-1}$ ($n > 0$).*

We will prove this theorem only for $n \leq 2$. Before giving the proof, we indicate and prove some interesting corollaries.

Corollary 9.2. *Assume that $f : S^n \rightarrow \mathbf{R}^n$ is a continuous map such that $f(-x) = -f(x)$ for any $x \in S^n$. Then, there exists a point $x \in S^n$ such that $f(x) = 0$.*

PROOF. Assume to the contrary that $f(x) \neq 0$ for all $x \in S^n$. For any $x \in S^n$, define

$$g(x) = \frac{f(x)}{|f(x)|}.$$

Then, g is a continuous map $S^n \rightarrow S^{n-1}$, which is antipode preserving, contrary to Theorem 9.1.

Corollary 9.3. *Assume $f : S^n \rightarrow \mathbf{R}^n$ is a continuous map. Then, there exists a point $x \in S^n$ such that $f(x) = f(-x)$. In particular, f is not one-to-one.*

PROOF. Assume to the contrary that, for every point $x \in S^n$, $f(x) \neq f(-x)$. Define $g(x) = f(x) - f(-x)$. Then, $g(-x) = -g(x)$, and $g(x) \neq 0$ for all x , which contradicts Corollary 9.2.

Corollary 9.4. *No subset of \mathbf{R}^n is homeomorphic to S^n .*

This is an obvious consequence of Corollary 9.3.

There is another interpretation of Corollary 9.3 which is interesting. If $f : S^n \rightarrow \mathbf{R}^n$ is a continuous map, we can write

$$f(x) = (f_1(x), \dots, f_n(x)),$$

where $f_1(x), \dots, f_n(x)$ are continuous real-valued functions on S^n . Thus, we may reword the corollary as follows: *Let f_1, f_2, \dots, f_n be continuous real-valued functions on S^n . Then, there exists a point $x \in S^n$ such that $f_i(x) = f_i(-x)$ for $i = 1, \dots, n$.* For example, if $f_1(x)$ and $f_2(x)$ denote the temperature and barometric pressure at a certain instant at any point x on the earth’s surface, and we assume that the temperature and barometric pressure both vary continuously over the earth’s surface, then we conclude that there exists a pair of antipodal points on the surface of the earth which simultaneously have the same temperature and pressure! This is a topological theorem par excellence; only topological hypotheses are involved in the statement and proof.

PROOF OF THEOREM 9.1. For $n \leq 2$: The case where $n = 1$ is trivial, because S^1 is connected, but S^0 is not connected. Therefore, we concentrate on the case where $n = 2$. The proof is by contradiction; assume that there exists a continuous antipode-preserving map $f : S^2 \rightarrow S^1$. Consider the quotient spaces of S^2 and S^1 obtained by identifying diametrically opposite points. These spaces are the real projective plane P_2 , and a space which is again homeomorphic to S^1 , respectively. We denote by $p_2 : S^2 \rightarrow P_2$ and $p_1 : S^1 \rightarrow S^1$ the natural maps of each space onto its quotient space. Because f is antipode preserving, it induces a continuous map $g : P_2 \rightarrow S^1$ such that the following diagram is commutative:

$$\begin{array}{ccc} S^2 & \xrightarrow{f} & S^1 \\ \downarrow p_2 & & \downarrow p_1 \\ P_2 & \xrightarrow{g} & S^1 \end{array}$$

Note that (S^2, p_2) and (S^1, p_1) are 2-sheeted covering spaces of P_2 and S^1 , respectively; this is a consequence of Proposition 8.2 (with G a cyclic group of order 2). We shall now reach a contradiction by an argument involving the induced homomorphism

$$g_* : \pi(P_2) \rightarrow \pi(S^1)$$

of the fundamental groups.

On the one hand, we know that $\pi(P_2)$ is cyclic of order 2, and $\pi(S^1)$ is infinite cyclic. Therefore, the homomorphism g_* must be trivial for purely algebraic reasons.

On the other hand, let α denote an equivalence class of paths on S^2 such

that the end points of α are antipodal points of S^2 . Because f is antipode preserving, the end points of $f_*(\alpha)$ are antipodal points of S^1 . Now, $p_{2*}(\alpha)$ and $p_{1*}f_*(\alpha)$ are closed paths on P_2 and S^1 , and hence represent elements of the fundamental groups, $\pi(P_2)$ and $\pi(S^1)$. We assert that $p_{2*}(\alpha) \neq 1$ and $p_{1*}f_*(\alpha) \neq 1$; this follows by considering the action of the fundamental groups $\pi(P_2, x_0)$ and $\pi(S^1, y_0)$ on the sets $p_2^{-1}(x_0)$ and $p_1^{-1}(y_0)$, respectively (see §7). It follows from the definitions that $p_{2*}(\alpha)$ and $p_{1*}f_*(\alpha)$ operate nontrivially on these sets. Next, by commutativity of the diagram above,

$$g_*p_{2*}(\alpha) = p_{1*}f_*(\alpha).$$

Therefore, g_* sends $p_{2*}(\alpha)$ onto $p_{1*}f_*(\alpha)$, contradicting the fact that g_* is trivial. Q.E.D.

It is clear that to prove the Brouwer fixed point theorem (see Chapter II) and the Borsuk-Ulam theorem in the cases where $n > 2$, we need higher dimensional analogs of the fundamental group. The fundamental group is essentially a 1-dimensional invariant of a space and will not suffice for this purpose. The proof of the Borsuk-Ulam theorem for the case where $n > 2$ will be given in the last chapter of this book, using cohomology groups and cup products.

EXERCISES

- 9.1. Generalize the argument used for proving the Borsuk-Ulam theorem as follows: Let X and Y be spaces which are connected and locally arcwise connected, let G be a group which operates on the left on X and Y such that it is a properly discontinuous group of homeomorphisms of each, and let $f: X \rightarrow Y$ be a continuous G -equivariant map (see Appendix B for the definition). Let $p: X \rightarrow X/G$ and $q: Y \rightarrow Y/G$ denote the natural maps, and let $g: X/G \rightarrow Y/G$ denote the map induced by f . Prove that the homomorphism $g_*: \pi(X/G) \rightarrow \pi(Y/G)$ induces an isomorphism of quotient groups: $\pi(X/G)/p_*\pi(X) \approx \pi(Y/G)/q_*\pi(Y)$.
- 9.2. Prove that following corollary of the general Borsuk-Ulam theorem: There does not exist a continuous 1-1 map $f: \mathbf{R}^{n+1} \rightarrow \mathbf{R}^n$ for any $n \geq 1$.
- 9.3. Does there exist a continuous antipode preserving map $f: S^1 \rightarrow S^1$ of even degree? Prove your answer.

§10. The Existence Theorem for Covering Spaces

We have proved that a covering space (\tilde{X}, p) of X is determined up to isomorphism by the conjugacy class of the subgroup $p_*\pi(\tilde{X}, \tilde{x})$ of $\pi(X, x)$. This fact gives rise to the following question: Suppose X is a topological space and we are given a conjugacy class of subgroups of $\pi(X, x)$. Does there exist a covering space (\tilde{X}, p) of X such that $p_*\pi(\tilde{X}, \tilde{x})$ belongs to the given conjugacy

class? We shall show that this question can be answered affirmatively, provided X satisfies a slight additional hypothesis.

First, we prove that it suffices to consider this problem for the special case where the given conjugacy class of subgroups consists of the trivial subgroup $\{1\}$.

Lemma 10.1. *Let X be a topological space which has a universal covering space. Then, for any conjugacy class of subgroups of $\pi(X, x)$, there exists a covering space (\tilde{X}, p) of X such that $p_*\pi(\tilde{X}, \tilde{x})$ belongs to the given conjugacy class.*

PROOF. Let (Y, q) be a universal covering space of X ; i.e., Y is simply connected. According to §7, $\pi(X, x)$ operates transitively on the right on the set $q^{-1}(x)$, and, since Y is simply connected, it operates without any fixed points. Also, the group of automorphisms $A(Y, q)$ is isomorphic to $\pi(X)$, and it operates transitively without fixed points on the left on the set $q^{-1}(x)$. Choose a point $y \in q^{-1}(x)$ and a subgroup G of $\pi(X, x)$, which belongs to the given conjugacy class. Let H be the subgroup of $A(Y, q)$ defined as follows: $\varphi \in H$ if and only if there exists an element $\alpha \in G$ such that $\varphi(y) = y \cdot \alpha$. It is readily seen that G and H are isomorphic under the following correspondence: $\varphi \leftrightarrow \alpha$ if and only if $\varphi(y) = y \cdot \alpha$.

Because H is a subgroup of $A(Y, q)$, it is a properly discontinuous group of homeomorphisms of Y . Let \tilde{X} denote the quotient space Y/H , $r: Y \rightarrow \tilde{X}$ the natural projection, and $p: \tilde{X} \rightarrow X$ the map induced by $q: Y \rightarrow X$. Then, we have the following commutative diagram:

$$\begin{array}{ccc}
 Y & & \\
 \downarrow q & \searrow r & \\
 & & \tilde{X} = \frac{Y}{H} \\
 & \swarrow p & \\
 X & &
 \end{array}$$

By assumption, (Y, q) is a covering space of X , and (Y, r) is a covering space of \tilde{X} by Proposition 8.2. It follows by an easy argument that (\tilde{X}, p) is a covering space of X (see Exercise 6.4). Since (\tilde{X}, p) is a covering space of X , the group $\pi(X, x)$ operates on the right on the set $p^{-1}(x)$. Let $\tilde{x} = r(y) \in p^{-1}(x)$. By our construction of \tilde{X} , it is clear that the isotropy subgroup of $\pi(X, x)$ corresponding to the point \tilde{x} is precisely the subgroup G . But this is exactly equivalent to the assertion that $p_*\pi(\tilde{X}, \tilde{x}) = G$ (see §7). Q.E.D.

We now consider the following problem: Given a topological space X , does X have a universal covering space? First, we derive a rather simple necessary condition. Let (\tilde{X}, p) be a universal covering space of X , let x be an arbitrary point of X , let \tilde{x} be a point $p^{-1}(x)$, let U be an elementary neighborhood of x , and let V be the component of $p^{-1}(U)$ which contains the point \tilde{x} . We then have the following commutative diagram involving fundamental groups:

$$\begin{array}{ccc}
 \pi(V, \tilde{x}) & \longrightarrow & \pi(\tilde{X}, \tilde{x}) \\
 (p|V)_* \downarrow & & \downarrow p_* \\
 \pi(U, x) & \xrightarrow{i_*} & \pi(X, x)
 \end{array}$$

Because $p|V$ is a homeomorphism of V onto U , $(p|V)_*$ is an isomorphism. Note also that, by hypothesis, $\pi(\tilde{X}, \tilde{x}) = \{1\}$. From these two facts and the commutativity of this diagram, it follows that i_* is a trivial homomorphism; i.e., image $i_* = \{1\}$. Thus, we conclude that the space X has the following property: *Every point $x \in X$ has a neighborhood U such that the homomorphism $\pi(U, x) \rightarrow \pi(X, x)$ is trivial.* A space which has this property is called *semilocally simply connected*.¹ This definition can also be phrased as follows: A space X is semilocally simply connected if and only if every point $x \in X$ has a neighborhood U such that any loop in U can be shrunk to a point in X .

The following is a simple example of a space which is connected and locally arcwise connected, but not semilocally simply connected. For any positive integer n , let

$$C_n = \left\{ (x, y) \in \mathbf{R}^2 : \left(x - \frac{1}{n}\right)^2 + y^2 = \frac{1}{n^2} \right\};$$

i.e., C_n is a circle of radius $1/n$ with center at the point $(1/n, 0)$. Let X denote the union of the circles C_n for all positive integers n . Then, X is not semilocally simply connected; the point $(0, 0)$ does not have the required kind of neighborhood.

Fortunately, most of the topological spaces that arise in problems from other branches of mathematics where covering spaces are involved are semilocally simply connected. For example, all manifolds and manifolds with boundary have this property.

We shall now prove that this necessary condition for the existence of a universal covering space is also sufficient.

Theorem 10.2. *Let X be a topological space which is connected, locally arcwise connected, and semilocally simply connected. Then, given any conjugacy class of subgroups of $\pi(X, x)$, there exists a covering space (\tilde{X}, p) of X corresponding to the given conjugacy class [i.e., such that $p_*\pi(\tilde{X}, \tilde{x})$ belongs to the given conjugacy class].*

PROOF. In view of Lemma 10.1, it suffices to prove that X has a universal covering space. This we will do by a direct construction. To motivate this

¹ This name is rather long and awkward, but it is an accurate description of the property in question. It lies between ordinary simple connectivity and true local simple connectivity (which we do not consider in this book). Moreover, this name is sanctioned by several years of common acceptance.

construction, we shall try to describe how an early topologist might have discovered it.

Let us assume for the moment that X has a universal covering space (\tilde{X}, p) . Choose a base point $\tilde{x}_0 \in \tilde{X}$, and let $x_0 = p(\tilde{x}_0)$. Given any point $y \in \tilde{X}$, there exists a path class α with initial point \tilde{x}_0 and terminal point y , because \tilde{X} is arcwise connected. Because \tilde{X} is simply connected, this path class is unique. Now consider the function which assigns to the point y the path class $p_*(\alpha)$ in X . It follows from Lemmas 3.1 and 3.3 that this is a one-to-one map of \tilde{X} onto the set of path classes in X which have x_0 as initial point. Thus, we can identify the points of \tilde{X} with the path classes in X which start at the point x_0 . This simple observation is the basis of the following construction.

Choose a base point $x_0 \in X$ and define \tilde{X} to be the set of all equivalence classes of paths α in X which have x_0 as their initial point. Define a function $p: \tilde{X} \rightarrow X$ by setting $p(\alpha)$ equal to the terminal point of the path class α . We shall now show how to topologize \tilde{X} so that it is a simply connected space and (\tilde{X}, p) is a covering space of X .

Observe that our hypotheses imply that the topology on X has a basis consisting of open sets U with the following properties: U is arcwise connected and the homomorphism $\pi(U) \rightarrow \pi(X)$ (induced by the inclusion map) is trivial. Equivalently, every closed path in U is equivalent (in X) to a constant path. For brevity let us agree to call such an open set U *basic*. Note that, if x and y are any two points in a basic open set U , then any two paths f and g in U with initial point x and terminal point y are equivalent (in X).

Given any path $\alpha \in \tilde{X}$ and any basic open set U which contains the end point $p(\alpha)$, denote by (α, U) the set of all paths $\beta \in \tilde{X}$ such that, for some path class α' in U , $\beta = \alpha \cdot \alpha'$. Then (α, U) is a subset of \tilde{X} . We topologize \tilde{X} by choosing as a basic family of open sets the family of all such sets (α, U) . In order that the family of all sets of the form (α, U) can be a basis for some topology on \tilde{X} , it is necessary to prove the following statement: If $\gamma \in (\alpha, U) \cap (\beta, V)$, then there exists a basic open set W such that $(\gamma, W) \subset (\alpha, U) \cap (\beta, V)$. However, the proof of this statement is easy: We choose W to be any basic open set such that $p(\gamma) \in W \subset U \cap V$.

Before proceeding with the proof that (\tilde{X}, p) is a universal covering space of X , it is convenient to make the following two simple observations:

- (a) Let $\alpha \in \tilde{X}$, and let U be a basic open neighborhood of $p(\alpha)$. Then, $p|(\alpha, U)$ is a one-to-one map of (α, U) onto U .
- (b) Let U be any basic open set, and let x be any point of U . Then,

$$p^{-1}(U) = \bigcup_{\lambda} (\alpha_{\lambda}, U),$$

where $\{\alpha_{\lambda}\}$ denotes the totality of all path classes in X with initial point x_0 and terminal point x . Moreover, the sets (α_{λ}, U) are pairwise disjoint.

The proof of these two observations is easy and can be left to the reader.

Note that it follows from (b) that p is continuous. Hence, $p|(\alpha, U)$ is a

one-to-one continuous map of (α, U) onto U , by (a). We assert that $p|(\alpha, U)$ is an open map of (α, U) onto U . For, any open subset of (α, U) is a union of sets of the form (β, V) , where $V \subset U$, and hence the fact that $p|(\alpha, U)$ is open also follows from (a). Thus, p maps (α, U) homeomorphically onto U . Since U is arcwise connected, so is (α, U) . Because the sets (α_λ, U) occurring in statement (b) are pairwise disjoint, it follows that any basic open set $U \subset X$ has all the properties required of an elementary neighborhood.

Next, we shall prove that the space \tilde{X} is arcwise connected. Let $\tilde{x}_0 \in \tilde{X}$ denote the equivalence class of the constant path at x_0 . Given any point $\alpha \in \tilde{X}$, it suffices to exhibit an arc joining the points \tilde{x}_0 and α . For this purpose, choose a path $f: I \rightarrow X$ belonging to the equivalence class α . For any real number $s \in I$, define $f_s: I \rightarrow X$ by $f_s(t) = f(st)$, $t \in I$. Then, $f_1 = f$ and $f_0 =$ constant path at x_0 . Let α_s denote the equivalence class of the path f_s . We assert that the map $s \rightarrow \alpha_s$ is a continuous map $I \rightarrow \tilde{X}$, i.e., a path in \tilde{X} . To prove this assertion, we must check that, for any $s_0 \in I$ and any basic neighborhood U of $f(s_0)$, there exists a real number $\delta > 0$ such that if $|s - s_0| < \delta$, then $\alpha_s \in (\alpha_{s_0}, U)$. For this purpose, we choose δ so that, if $|s - s_0| < \delta$, then $f(s) \in U$; such a number δ exists because f is continuous. Thus, $s \rightarrow \alpha_s$ is a path in \tilde{X} with initial point \tilde{x}_0 and terminal point α , as required.

Finally, we must prove that \tilde{X} is simply connected. Now $p_*\pi(\tilde{X}, \tilde{x}_0)$ is the isotropy subgroup corresponding to the point \tilde{x}_0 for the action of $\pi(X, x_0)$ on $p^{-1}(x_0)$ (see §7). Thus, we must determine $\tilde{x}_0 \cdot \alpha$ for any $\alpha \in \pi(X, x_0)$. Choose a closed path $f: I \rightarrow X$ belonging to the equivalence class α , and, by the method of the preceding paragraph, define the path $s \rightarrow \alpha_s$ in \tilde{X} . This path in \tilde{X} has \tilde{x}_0 as initial point, $\alpha \in \tilde{X}$ as terminal point, and is obviously a lifting of the path f . Hence, $\tilde{x}_0 \cdot \alpha = \alpha$, by the definition of the action of $\pi(X, x_0)$ on $p^{-1}(x_0)$. Therefore, $\tilde{x}_0 \cdot \alpha = \tilde{x}_0$ if and only if $\alpha = 1$; hence, the isotropy subgroup consists of the element 1 alone, as required. Q.E.D.

EXERCISES

- 10.1. Prove that for any positive integer n there exists a noncompact surface S and a properly discontinuous group G of homeomorphisms of S such that G is a free abelian group of rank $2n$ and S/G is a compact, orientable surface of genus n .

NOTES

Branched covering spaces

The Riemann surface of a so-called “multiple-valued” analytic function in the complex plane is usually not a covering space of the domain of definition of the function because of the existence of “branch points.” It is an example of a “branched” or “ramified” covering space. The idea of a branched covering has turned out to be useful in several different areas of mathematics. Usually branched covering spaces are considered in the context of manifolds rather

than more general topological spaces, and only branched coverings having finitely many sheets are allowed. For two quite different rather general definitions of branched covering spaces, see the article by R.H. Fox entitled “Covering Spaces with Singularities” in the book *Algebraic Geometry and Topology: A Symposium in Honor of S. Lefschetz* (Princeton University Press, Princeton, N.J., 1957) and the paper by A. Dold entitled “Ramified Coverings, Orbit Projections, and Symmetric Powers” [*Math. Proc. Camb. Phil. Soc.* **99** (1986), 65–72]. There is no extensive general theory about branched covering spaces, although a great deal is known in various special cases, e.g., for 2-dimensional manifolds.

Covering spaces without any connectivity assumptions

It is natural to ask whether the assumptions of connectedness and local arcwise connectedness, which played such an important role in this chapter, can be weakened or omitted. Certainly the definition of a covering space can be formulated so as to avoid any reference to these assumptions; and some of the basic lemmas and theorems of this chapter can be proved under weakened hypotheses. For a treatment of covering spaces in such a context, see Spanier [7]. However, the principal theorems of this chapter, which establish a close connection between the theory of covering spaces and the fundamental group, seem to require assumptions of connectedness and local arcwise connectedness. In situations where the theory of covering spaces finds natural application the spaces involved usually satisfy all the needed hypotheses.

The reader’s attention should be called to the example on p. 158 of Hilton and Wylie [2]. This example shows the necessity of the assumption that Y be locally arcwise connected in Theorem 5.1.

Covering spaces as fiber spaces or fiber bundles

The reader who is familiar with the theory of fiber spaces and fiber bundles will recognize that a covering space as we have defined the term is a locally trivial fiber space with a discrete fiber. Thus, the theory of covering spaces may be considered as a chapter in the general theory of fiber spaces. We may also consider that a covering space (X, p) of X is a fiber bundle with $\pi(X)$ as structural group and the discrete homogeneous space $\pi(X)/p_*\pi(\tilde{X})$ as the fiber. The regular covering spaces then correspond to the principal fiber bundles. This topic is discussed in Sections 13 and 14 of the book *The Topology of Fiber Bundles* by N. E. Steenrod (Princeton University Press, Princeton, N.J., 1951); see also Spanier [7].

Higher homotopy groups of a covering space

For any space X and point $x_0 \in X$, the notation $\pi_n(X, x_0)$ denotes the set of all homotopy classes of maps $(S^n, y_0) \rightarrow (X, x_0)$; here $y_0 \in S^n$ and it is understood that all homotopies are relative to the chosen base point y_0 (see §II.4

for the definition of relative homotopy). Note that, for $n = 1$, $\pi_1(X, x_0) = \pi(X, x_0)$ is just the fundamental group. It is also possible to define in a natural way an addition in $\pi_n(X, X_0)$ for $n > 1$, so that it becomes an abelian group, called *the n th homotopy group of X* . We assert that, if (\tilde{X}, p) is a covering space of X , the projection p induces an isomorphism of $\pi_n(\tilde{X}, x)$ onto $\pi_n(X, p(x))$ for any point $x \in \tilde{X}$ and any integer $n > 1$. The proof is a simple application of Theorem 5.1. If $\varphi : (S^n, y_0) \rightarrow (X, p(x))$ is any continuous map, then there exists a unique map $\tilde{\varphi} : (S^n, y_0) \rightarrow (\tilde{X}, x)$ such that $p\tilde{\varphi} = \varphi$. Moreover, two such maps, $\varphi_0, \varphi_1 : (S^n, y_0) \rightarrow (X, p(x))$ are homotopic (relative to y_0) if and only if the corresponding lifted maps $\tilde{\varphi}_0, \tilde{\varphi}_1 : (S^n, y_0) \rightarrow (\tilde{X}, x)$ are homotopic.

This result is often useful in the study of higher homotopy groups.

Determination of all covering spaces with a finite number of sheets

In general, we probably cannot hope for an *effective* procedure for determining all covering spaces of a given space X [or equivalently, of determining all conjugacy classes of subgroups of $\pi(X)$]. However, if the fundamental group $\pi(X)$ is finitely presented, then for any given integer n there is an effective procedure for finding all n -sheeted covering spaces of X . This procedure is illustrated on pp. 207–210 of Seifert and Threlfall [3].

The Jordan curve theorem

A proof of the Jordan curve theorem using the theory of fundamental groups and covering spaces may be found in Munkres, [6, pp. 374–386]. This book also has exercises which contain an outline of a proof of the Brouwer theorem on “Invariance of Domain” in the plane.

References

1. C. Chevalley, *The Theory of Lie Groups I*, Princeton University Press, Princeton, N.J., 1964, Chapter II, Sections VI–X.
2. P. J. Hilton and S. Wylie, *Homology Theory, An Introduction to Algebraic Topology*, The University Press, Cambridge, 1960, Chapter 6.
3. H. Seifert and W. Threlfall, *A Textbook of Topology*, Academic Press, New York, 1980, Chapter 8.
4. S. Kinoshita, Notes on Covering Transformation Groups. *Proc. Am. Math. Soc.* **19** (1968), 421–424.
5. W. J. Gray, A Note on Covering Transformations, *Indag. Math.* **31** (1969), 283–284.
6. J. R. Munkres, *Topology: A First Course*, Prentice–Hall, Englewood Cliffs, N.J., 1975, Chapter 8.
7. E. H. Spanier, *Algebraic Topology*, McGraw–Hill, New York, 1966, Chapter 2.

CHAPTER VI

Background and Motivation for Homology Theory

§1. Introduction

Homology theory is a subject whose development requires a long chain of definitions, lemmas, and theorems before it arrives at any interesting results or applications. A newcomer to the subject who plunges into a formal, logical presentation of its ideas is likely to be somewhat puzzled because he will probably have difficulty seeing any motivation for the various definitions and theorems. It is the purpose of this chapter to present some explanation, which will help the reader to overcome this difficulty. We offer two different kinds of material for background and motivation. First, there is a summary of some of the most easily understood properties of homology theory, and a hint at how it can be applied to specific problems. Second, there is a brief outline of some of the problems and ideas which led certain mathematicians of the nineteenth century to develop homology theory.

It should be emphasized that the reading of this chapter is *not* a logical prerequisite to the understanding of anything in later chapters of this book.

§2. Summary of Some of the Basic Properties of Homology Theory

Homology theory assigns to any topological space X a sequence of abelian groups $H_0(X)$, $H_1(X)$, $H_2(X)$, \dots , and to any continuous map $f: X \rightarrow Y$ a sequence of homomorphisms

$$f_* : H_n(X) \rightarrow H_n(Y), \quad n = 0, 1, 2, \dots$$

$H_n(X)$ is called the *n-dimensional homology group of X*, and f_* is called *the homomorphism induced by f*. We will list in more or less random order some of the principal properties of these groups and homomorphisms.

(a) If $f: X \rightarrow Y$ is a homeomorphism of X onto Y , then the induced homomorphism $f_*: H_n(X) \rightarrow H_n(Y)$ is an isomorphism for all n . Thus, the algebraic structure of the groups $H_n(X)$, $n = 0, 1, 2, \dots$, depends only on the topological type of X . In fact, an even stronger statement holds: if f is a homotopy equivalence, then f_* is an isomorphism. Thus, the structure of $H_n(Y)$ only depends on the homotopy type of X . Two spaces of the same homotopy type have isomorphic homology groups (for the definition of these terms, the reader is referred to Chapter II, §4 and §8).

(b) If two maps $f_0, f_1: X \rightarrow Y$ are homotopic, then the induced homomorphisms f_{0*} and $f_{1*}: H_n(X) \rightarrow H_n(Y)$ are the same for all n . Thus, the induced homomorphism f_* only depends on the homotopy class of f . By its use, we can sometimes prove that certain maps are *not* homotopic.

(c) For any space X , the group $H_0(X)$ is free abelian, and its rank is equal to the number of arcwise connected components of X . In other words, $H_0(X)$ has a basis in 1–1 correspondence with the set of arc components of X . Thus, the structure of $H_0(X)$ has to do with the arcwise connectedness of X . By analogy, the groups $H_1(X)$, $H_2(X)$, \dots have something to do with some kind of higher connectivity of X . In fact, one can look on this as one of the principal purposes for the introduction of the homology groups: to express what may be called the higher connectivity properties of X .

(d) If X is an arcwise-connected space, the 1-dimensional homology group, $H_1(X)$, is the abelianized fundamental group. In other words, $H_1(X)$ is isomorphic to $\pi(X)$ modulo its commutator subgroup.

(e) If X is a compact, connected, orientable n -dimensional manifold, then $H_n(X)$ is infinite cyclic, and $H_q(X) = \{0\}$ for all $q > n$. In some vague sense, such a manifold is a prototype or model for nonzero n -dimensional homology groups.

(f) If X is an open subset of Euclidean n -space, then $H_q(X) = \{0\}$ for all $q \geq n$.

We have already alluded to the fact that sometimes it is possible to use homology theory to prove that two continuous maps are not homotopic. Analogously, homology groups can sometimes be used to prove that two spaces are not homeomorphic, or not even of the same homotopy type. These are rather obvious applications. In other cases, homology theory is used in less obvious ways to prove theorems. A nice example of this is the proof of the Brouwer fixed-point theorem in Chapter VIII, §2. More subtle examples are the Borsuk–Ulam theorem in Chapter XV, §2 and the Jordan–Brouwer separation theorem in Chapter VIII, §6.

§3. Some Examples of Problems Which Motivated the Development of Homology Theory in the Nineteenth Century

The problems we are going to consider all have to do with line integrals, surface integrals, etc., and theorems relating these integrals, such as the well-known theorems of Green, Stokes, and Gauss. We assume the reader is familiar with these topics.

As a first example, consider the following problem which is discussed in most advanced calculus books. Let U be an open, connected set in the plane, and let V be a vector field in U (it is assumed that the components of V have continuous partial derivatives in U). Under what conditions does there exist a "potential function" for V , i.e., a differentiable function $F(x, y)$ such that V is the gradient of F ? Denote the x and y components of V by $P(x, y)$ and $Q(x, y)$ respectively; then an obvious necessary condition is that

$$\frac{\partial P}{\partial y} = \frac{\partial Q}{\partial x}$$

at every point of U . If the set U is convex, then this necessary condition is also sufficient. The standard proof of sufficiency is based on the use of Green's theorem, which asserts that

$$\oint_C P dx + Q dy = \iint_D \left(\frac{\partial Q}{\partial x} - \frac{\partial P}{\partial y} \right) dx dy.$$

Here D is a domain with piecewise smooth boundary C (which may have several component) such that D and C are both contained in U . By using Green's theorem, one can prove that the line integral on the left-hand side vanishes if C is any closed curve in U . This implies that if (x_0, y_0) and (x, y) are any two points of U , and L is any piecewise smooth path in U joining (x_0, y_0) and (x, y) , then the line integral

$$\int_L P dx + Q dy$$

is independent of the choice of L ; it only depends on the end points (x_0, y_0) and (x, y) . If we hold (x_0, y_0) fixed, and define $F(x, y)$ to be the value of this line integral for any point (x, y) in U , then $F(x, y)$ is the desired potential function.

On the other hand, if the open set U is more complicated, the necessary condition $\partial P/\partial y = \partial Q/\partial x$ may not be sufficient. Perhaps the simplest example to illustrate this point is the following: Let U denote the plane with the origin deleted,

$$P = -\frac{y}{x^2 + y^2} \quad \text{and} \quad Q = \frac{x}{x^2 + y^2}.$$

Then the condition $\partial Q/\partial x = \partial P/\partial y$ is satisfied at each point of U . However, if we compute the line integral

$$\int_C P dx + Q dy, \quad (6.3.1)$$

where C is a circle with center at the origin, we obtain the value 2π . Since $2\pi \neq 0$, there cannot be any potential function for the vector field $\mathbf{V} = (P, Q)$ in the open set U . It is clear where the preceding proof breaks down in this case: the circle C (with center at the origin) does not bound any domain D such that $D \subset U$.

Since the line integral (1) may be nonzero in this case, we may ask, What are all possible values of this line integral as C ranges over all piecewise smooth closed curves in U ? The answer is $2n\pi$, where n ranges over all integers, positive or negative. Indeed, any of these values may be obtained by integrating around the unit circle with center at the origin an appropriate number of times in the clockwise or counterclockwise direction; and an informal argument using Green's theorem should convince the reader that these are the only possible values.

We can ask the same question for any open, connected set U in the plane, and any continuously differentiable vector field $\mathbf{V} = (P, Q)$ in U satisfying the condition $\partial P/\partial y = \partial Q/\partial x$: What are all possible values of the line integral (6.3.1) as C ranges over all piece-wise smooth closed curves in U ? Anybody who studies this problem will quickly come to the conclusion that the answer depends on the number of "holes" in the set U . Let us associate with each hole the value of the integral (6.3.1) in the case where C is a closed path which goes around the given hole exactly once and does not encircle any other hole (assuming such a path exists). By analogy with complex function theory, we will call this number the *residue* associated with the given hole. The answer to our problem then is that the value of the integral (6.3.1) is some finite, integral linear combination of these residues, and any such finite integral linear combination actually occurs as a value.

Next, let us consider the analogous problem in 3-space: we now assume that U is an open, connected set in 3-space, and \mathbf{V} is a vector field in U with components $P(x, y, z)$, $Q(x, y, z)$, and $R(x, y, z)$ (which are assumed to be continuously differentiable in U). Furthermore, we assume that $\text{curl } \mathbf{V} = 0$. In terms of the components, this means that the equations

$$\frac{\partial R}{\partial y} = \frac{\partial Q}{\partial z}, \quad \frac{\partial P}{\partial z} = \frac{\partial R}{\partial x}, \quad \text{and} \quad \frac{\partial Q}{\partial x} = \frac{\partial P}{\partial y}$$

hold at each point of U . Once again it can be shown that if U is convex, then there exists a function $F(x, y, z)$ such that \mathbf{V} is the gradient of F . The proof is much the same as the previous case, except that now one must use Stokes's theorem rather than Green's theorem to show that the line integral

$$\int P dx + Q dy + R dz$$

is independent of the path.

In case the domain U is not convex, this proof may break down, and it can actually happen that the line integral

$$\oint_C P dx + Q dy + R dz \quad (6.3.2)$$

is nonzero for some closed path C in U . Once again we can ask: What are all possible values of the line integral (2) for all possible closed paths in U ? The “holes” in U are again what makes the problem interesting; however, in this case there seem to be different kinds of holes. Let us consider some examples:

(a) Let $U = \{(x, y, z) | x^2 + y^2 > 0\}$, i.e., U is the complement of the z axis. This example is similar to the 2-dimensional case treated earlier. If C denotes a circle in the xy plane with center at the origin, we could call the value of the integral (6.3.2) with this choice of C the residue corresponding to the hole in U . Then the value of the integral (6.3.2) for any other choice of C in U would be some integral multiple of this residue; the reader should be able to convince himself of this in any particular case by using Stokes’s theorem.

(b) Let U be the complement of the origin in \mathbf{R}^3 . If Σ is any piecewise smooth orientable surface in U with boundary C consisting of one or more piecewise smooth curves, then according to Stokes’s theorem,

$$\begin{aligned} \oint_C P dx + Q dy + R dz &= \iint_{\Sigma} \left(\frac{\partial R}{\partial y} - \frac{\partial Q}{\partial z} \right) dy dz \\ &\quad + \left(\frac{\partial P}{\partial z} - \frac{\partial R}{\partial x} \right) dz dx + \left(\frac{\partial Q}{\partial x} - \frac{\partial P}{\partial y} \right) dx dy. \end{aligned}$$

We leave it to the reader to convince himself that any piecewise smooth closed curve c in U is the boundary of such a surface Σ , hence by Stokes’s theorem, the integral around such a curve is zero (the integral on the right-hand side is identically zero). Thus, the same argument applies as in the case where U is convex to show that any vector field \mathbf{V} in U such that $\text{curl } \mathbf{V} = 0$ in U is of the form $\mathbf{V} = \text{grad } F$ for some function F . The existence of the hole in U does not matter in this case.

(c) It is easy to give other examples of domains in 3-space with holes in them such that the hole does not matter. The following are such examples: let $U_1 = \{(x, y, z) | x^2 + y^2 + z^2 > 1\}$; let U_2 be the complement of the upper half ($z \geq 0$) of the z axis; and let U_3 be the complement of a finite set of points in 3-space. In each case, if \mathbf{V} is a vector field in U_i such that $\text{curl } \mathbf{V} = 0$, then $\mathbf{V} = \text{grad } F$ for some function F . The basic reason is that any closed curve C in U_i is the boundary of some oriented surface Σ in U_i in each of the cases $i = 1, 2, \text{ or } 3$.

There is another problem for 3-dimensional space which involves closed surfaces rather than closed curves. It may be phrased as follows: Let U be a connected open set in \mathbf{R}^3 and let \mathbf{V} be a continuously differentiable vector field in U such that $\operatorname{div} \mathbf{V} = 0$. Is the integral of (the normal component of) \mathbf{V} over any closed, orientable piecewise smooth surface Σ in U equal to 0? If not, what are the possible values of the integral of \mathbf{V} over any such closed surface? If U is a convex open set, then any such integral is 0. One proves this by the use of Gauss's theorem (also called the divergence theorem):

$$\iint_{\Sigma} \mathbf{V} = \iiint_D (\operatorname{div} \mathbf{V}) \, dx \, dy \, dz.$$

Here D is a domain in U with piecewise smooth boundary Σ (the boundary may have several components). The main point is that a closed orientable surface Σ contained in a convex open set U is always the boundary of a domain D contained in U . However, if the open set U has holes in it, this may not be true, and the situation is more complicated. For example, suppose that U is the complement of the origin in 3-space, and \mathbf{V} is the vector field in U with components $P = x/r^3$, $Q = y/r^3$, and $R = z/r^3$, where $r = (x^2 + y^2 + z^2)^{1/2}$ is the distance from the origin. It is readily verified that $\operatorname{div} \mathbf{V} = 0$; on the other hand, the integral of \mathbf{V} over any sphere with center at the origin is readily calculated to be $\pm 4\pi$; the sign depends on the orientation conventions. The set of all possible values of the surface integral $\iint_{\Sigma} \mathbf{V}$ for all closed, orientable surfaces Σ in U is precisely the set of all integral multiples of 4π .

On the other hand, if U is the complement of the z axis in 3-space, then the situation is exactly the same as in the case where U is convex. The reason is that any closed, orientable surface in U bounds a domain D in U ; the existence of the hole in U does not matter.

There is a whole series of analogous problems in Euclidean spaces of dimension four or more. Also, one could consider similar problems on curved submanifolds of Euclidean space. Although there would doubtless be interesting new complications, we have already presented enough examples to give the flavor of the subject.

At some point in the nineteenth century certain mathematicians tried to set up general procedures to handle problems such as these. This led them to introduce the following terminology and definitions. The closed curves, surfaces, and higher-dimensional manifolds over which one integrates vector fields, etc., were called *cycles*. In particular, a closed curve is a 1-dimensional cycle, a closed surface is a 2-dimensional cycle, and so on. To complete the picture, a 0-dimensional cycle is a point. It is understood, of course, that cycles of dimension > 0 always have a definite orientation, i.e., a 2-cycle is an oriented closed surface. Moreover, it is convenient to attach to each cycle a certain integer which may be thought of as its "multiplicity." To integrate a vector field over a 1-dimensional cycle or closed curve with multiplicity $+3$ means to integrate it over a path going around the curve 3 times; the result will be

three times the value of the integral going around it once. If the multiplicity is -3 , then one integrates three times around the curve in the opposite direction. If the symbol c denotes a 1-dimensional cycle, then the symbol $3c$ denotes this cycle with the multiplicity $+3$, and $-3c$ denotes the same cycle with multiplicity -3 . It is also convenient to allow formal sums and linear combinations of cycles (all of the same dimension), that is, expressions like $3c_1 + 5c_2 - 10c_3$, where c_1 , c_2 , and c_3 are cycles. With this definition of addition, the set of all n -dimensional cycles in an open set U of Euclidean space becomes an abelian group; in fact it is a free abelian group. It is customary to denote this group by $Z_n(U)$. There is one further convention that is understood here: If c is the 1-dimensional cycle determined by a certain oriented closed curve, and c' denotes the cycle determined by the same curve with the opposite orientation, then $c = -c'$. This is consistent with the fact that the integral of a vector field over c' is the negative of the integral over c . Of course, the same convention also holds for higher-dimensional cycles.

It is important to point out that 1-dimensional cycles are only assumed to be closed curves; they are not assumed to be *simple* closed curves. Thus, they may have various self-intersections or singularities. Similarly, a 2-dimensional cycle in U is an oriented surface in U which is allowed to have various self-intersections or singularities. It is really a continuous (or differentiable) mapping of a compact, connected, oriented 2-manifold into U . Because of the possible existence of self-intersections or singularities, these cycles are often called *singular* cycles.

Once one knows how to define the integral of a vector field (or differential form) over a cycle, it is obvious how to define the integral over a formal linear combination of cycles. If c_1, \dots, c_k are cycles in U and

$$z = n_1 c_1 + \cdots + n_k c_k,$$

where n_1, n_2, \dots, n_k are integers, then

$$\int_z \mathbf{V} = \sum_{i=1}^k n_i \int_{c_i} \mathbf{V}$$

for any vector field \mathbf{V} in U .

The next step is to define an equivalence relation between cycles. This equivalence relation is motivated by the following considerations. Assume that U is an open set in 3-space.

- (a) Let u and w be 1-dimensional cycles in U , i.e., u and w are elements of the groups $Z_1(U)$. Then we wish to define $u \sim w$ so that this implies

$$\int_u \mathbf{V} = \int_w \mathbf{V}$$

for any vector field \mathbf{V} in U such that $\text{curl } \mathbf{V} = 0$.

- (b) Let u and w be elements of the group $Z_2(U)$. Then we wish to define $u \sim w$ so that this implies

$$\int_u \mathbf{V} = \int_w \mathbf{V}$$

for any vector field \mathbf{V} in U such that $\operatorname{div} \mathbf{V} = 0$.

Note that the condition

$$\int_u \mathbf{V} = \int_w \mathbf{V}$$

can be rewritten as follows, in view of our conventions:

$$\int_{u-w} \mathbf{V} = 0.$$

Thus, $u \sim w$ if and only if $u - w \sim 0$.

In case (a), Stokes's theorem suggests the proper definition, while in case (b) the divergence theorem points the way.

We will discuss case (a) first. Suppose we have an oriented surface in U whose boundary consists of the oriented closed curves c_1, c_2, \dots, c_k . The orientations of the boundary curves are determined according to the conventions used in the statement of Stokes's theorem. Then the 1-dimensional cycle

$$z = c_1 + c_2 + \cdots + c_k$$

is defined to be *homologous to zero*, written

$$z \sim 0.$$

More generally, any linear combination of cycles homologous to zero is also defined to be homologous to zero. The set of all cycles homologous to zero is a subgroup of $Z_1(U)$ which is denoted by $B_1(U)$. We define z and z' to be homologous (written $z \sim z'$) if and only if $z - z' \sim 0$. Thus, the set of equivalence classes of cycles, called *homology classes*, is nothing other than the quotient group

$$H_1(U) = Z_1(U)/B_1(U)$$

which is called the 1-dimensional *homology group* of U .

Analogous definitions apply to case (b). Let D be a domain in U whose boundary consists of the connected oriented surfaces s_1, s_2, \dots, s_k . The orientation of the boundary surfaces is determined by the conventions used for the divergence theorem. Then the 2-dimensional cycle

$$z = s_1 + s_2 + \cdots + s_k$$

is by definition homologous to zero, written $z \sim 0$. As before, any linear combination of cycles homologous to zero is also defined to be homologous to 0, and the set of cycles homologous to 0 constitutes a subgroup, $B_2(U)$, of $Z_2(U)$. The quotient group

$$H_2(U) = Z_2(U)/B_2(U)$$

is called the 2-dimensional *homology group* of U .

Let us consider some examples. If U is an open subset of the plane, then $H_1(U)$ is a free abelian group, and it has a basis (or minimal set of generators) in 1–1 correspondence with the holes in U . If U is an open subset of 3-spaces, then both $H_1(U)$ and $H_2(U)$ are free abelian groups, and each hole in U contributes generators to $H_1(U)$ or $H_2(U)$, or perhaps to both. This helps explain the different kinds of holes in this case.

In principle, there is nothing to stop us from generalizing this procedure, and defining for any topological space X and non-negative integer n the group $Z_n(X)$ of n -dimensional cycles in X , the subgroup $B_n(X)$ consisting of cycles which are homologous to zero, and the quotient group

$$H_n(X) = Z_n(X)/B_n(X),$$

called the n -dimensional homology group of X . However, there are difficulties in formulating the definitions rigorously in this generality; the reader may have noticed that some of the definitions in the preceding pages were lacking in precision. Actually, it took mathematicians some years to surmount these difficulties. The key idea was to think of an n -dimensional cycle as made up of small n -dimensional pieces which fit together in the right way, in much the same way that bricks fit together to make a wall. In this book, we will use n -dimensional cycles that consist of n -dimensional cubes which fit together in a nice way. To be more precise, the “singular” cycles will be built from “singular” cubes; a singular n -cube in a topological space X is simply a continuous map $T: I^n \rightarrow X$, where I^n denotes the unit n -cube in Euclidean n -space.

There is another complication which should be pointed out. We mentioned in connection with the examples above that if U is an open subset of the plane or 3-space, then the homology groups of U are free abelian groups. However, there exist open subsets U of Euclidean n -space for all $n > 3$ such that the group $H_1(U)$ contains elements of finite order (compare the discussion of the homology groups of nonorientable surfaces in §VIII.4). Suppose that $u \in H_1(U)$ is a homology class of order $k \neq 0$. Let z be a 1-dimensional cycle in the homology class u . Then z is not homologous to 0, but $k \cdot z$ is homologous to 0. This implies that if \mathbf{V} is any vector field in U such that $\text{curl } \mathbf{V} = 0$, then

$$\int_z \mathbf{V} = 0.$$

To see this, let $\int_z \mathbf{V} = r$. Then $\int_{kz} \mathbf{V} = k \cdot r$; but $\int_{kz} \mathbf{V} = 0$ since $kz \sim 0$. Therefore $r = 0$. It is not clear that this phenomenon was understood in the nineteenth century; at least there seems to have been some confusion in Poincaré’s early papers on topology about this point. Of course, one source of difficulty is the fact that this phenomenon eludes our ordinary geometric intuition, since it does not occur in 3-dimensional space. Nevertheless it is a phenomenon of importance in algebraic topology.

Before ending this account, we should make clear that we do not claim that the nineteenth century development of homology theory actually proceeded along the lines we have just described. For one thing, the nineteenth century mathematicians involved in this development were more interested in complex analysis than real analysis. Moreover, many of their false starts and tentative attempts to establish the subject can only be surmised from reading the published papers which have survived to the present. For a fairly readable nineteenth century account of some of these ideas, the reader is referred to the famous book by J. C. Maxwell [6].

The modern development of these same ideas led to De Rham's theorem; see Appendix A.

NOTES

The history of algebraic topology

The early development of what is now called algebraic topology occurred mainly in the nineteenth century. Even in the early part of that century some mathematicians, such as Gauss, foresaw the need for such a development. In those days topology was referred to as "analysis situs." The work of Riemann on complex function theory in the middle of the century was a strong stimulus for the further development of the subject, especially for the topology of surfaces. Unfortunately, Riemann never published his ideas on algebraic topology; the brief "Fragment" [10] published after his death in his collected works seems rather vague and incomprehensible. Riemann contracted tuberculosis in 1862 and spent much of the few remaining years of his life in Italy, trying to regain his health. While there, he discussed his ideas on topology with some Italian mathematicians, especially Professor Enrico Betti of Pisa. Some of Betti's letters to other Italian mathematicians have been published; he writes of the things he has learned from Riemann. Betti published on these topics in a paper [1] after Riemann's death. In 1895 Poincaré tried to further develop the ideas of Riemann and Betti in a long paper entitled "Analysis Situs" [7]. The Danish mathematician P. Heegard in his Copenhagen thesis of 1898 criticized certain aspects of Poincaré's paper. This apparently forced Poincaré to reexamine his ideas, and in subsequent "Complements" to his original paper on analysis situs he changed his point of view and created what was to become homology theory.

Background and motivation for homology theory

The student may find it helpful to read further articles on this subject. Several such articles are listed in the bibliography below. The books by Blakett [11] and Frechet and Fan [12] have bibliographies which list many additional articles that are helpful and interesting.

References

History of Algebraic Topology

1. E. Betti, Sopra gli spazi di un numero qualunque di dimensioni, *Ann. Mat. Pura Appl.* **4** (1871), 140–158.
2. M. Bollinger, Geschichtliche Entwicklung des Homologiebegriffs, *Arch. Hist. Exact Sci.* **9** (1972), 94–166.
3. J. Dieudonné, Les débuts de la topologie algébrique, *Expositiones Math.* **3** (1985), 347–357.
4. J. Dieudonné, *A History of Algebraic and Differential Topology: 1900–1960*. Birkhäuser Boston, Inc., New York, 1989.
5. S. Lefschetz, The Early Development of Algebraic Topology, *Bol. da Soc. Brasileira Mat.* **1** (1970), 1–48.
6. J. C. Maxwell, *A Treatise on Electricity and Magnetism*. Oxford University Press, Oxford, 1873 (1st ed.); 1881 (2nd ed.); 1904 (3rd ed.).
7. H. Poincaré, *Oeuvres*, Gauthier-Villars, Paris, 1953, Vol. VI, pp. 183–499.
8. Jean-Claude Pont, *La Topologie Algébrique, des Origines à Poincaré*, Presses Universitaires de France, Paris, 1974.
9. Jean-Claude Pont, Petit Enfance de la Topologie Algébrique, *L'Enseignement Math.* **20** (1974), 111–126 (a brief summary of the preceding book).
10. G. F. B. Riemann, Fragment aus der Analysis Situs, in *Gesammelte Mathematische Werke* (2nd ed.), Dover, New York, 1953, pp. 479–483.

Motivation and Background for Homology Theory

11. D. W. Blakett, *Elementary Topology, A Combinatorial and Algebraic Approach*, Academic Press, New York, 1967, p. 219.
12. M. Frechet and K. Fan, *Initiation to Combinatorial Topology*, Prindle, Weber, and Schmidt, Boston, 1967, pp. 113–119.
13. J. G. Hocking and G. S. Young, *Topology*, Addison-Wesley, Reading, Mass., 1961, pp. 218–222.
14. H. Seifert and W. Threlfall, *A Textbook of Topology*, Academic Press, New York, 1980, Chapter 1.
15. A. H. Wallace, *An Introduction to Algebraic Topology*, Pergamon Press, Elmsford, N.Y., 1957. pp. 92–95.

CHAPTER VII

Definitions and Basic Properties of Homology Theory

§1. Introduction

This chapter gives formal definitions of the basic concepts of homology theory, and rigorous proofs of their basic properties. For the most part, examples and applications are postponed to Chapter VIII and subsequent chapters.

For the rest of this book, *all abelian groups will be written additively*, unless there is an explicit statement to the contrary.

§2. Definition of Cubical Singular Homology Groups

First, we list some terminology and notation which will be used from here on.

\mathbf{R} = real line.

I = closed unit interval, $[0, 1]$.

$\mathbf{R}^n = \mathbf{R} \times \mathbf{R} \times \cdots \times \mathbf{R}$ (n factors, $n > 0$) Euclidean n -space.

$I^n = I \times I \times \cdots \times I$ (n factors, $n > 0$) unit n -cube.

By definition, I^0 is a space consisting of a single point.

Any topological space homeomorphic to I^n may be called an n -dimensional cube.

Definition 2.1. A *singular n -cube* in a topological space X is a continuous map $T: I^n \rightarrow X$ ($n \geq 0$).

Note the special cases $n = 0$ and $n = 1$.

$Q_n(X)$ denotes the free abelian group generated by the set of all singular n -cubes in X . Any element of $Q_n(X)$ has a unique expression as a finite linear combination with integral coefficients of n -cubes in X .

Definition 2.2. A singular n -cube $T: I^n \rightarrow X$ is *degenerate* if there exists an integer i , $1 \leq i \leq n$, such that $T(x_1, x_2, \dots, x_n)$ does not depend on x_i .

Note that a singular 0-cube is never degenerate; a singular 1-cube $T: I \rightarrow X$ is degenerate if and only if T is a constant map.

Let $D_n(X)$ denote the subgroup of $Q_n(X)$ generated by the degenerate singular n -cubes, and let $C_n(X)$ denote the quotient group $Q_n(X)/D_n(X)$. The latter is called the group of *cubical singular n -chains in X* , or just *n -chains in X* for simplicity.

Remark: If $X = \emptyset$, the empty set, then $Q_n(X) = D_n(X) = C_n(X) = \{0\}$ for all $n \geq 0$.

If X is a space consisting of a single point, then there is a unique singular n -cube in X for all $n \geq 0$; this unique n -cube is degenerate if $n \geq 1$. Hence $C_0(X)$ is an infinite cyclic group and $C_n(X) = \{0\}$ for $n > 0$ in this case.

For any space X , $D_0(X) = \{0\}$, hence $C_0(X) = Q_0(X)$.

For any space X , it is readily verified that for $n \geq 1$, $C_n(X)$ is a free abelian group on the set of all nondegenerate n -cubes in X (or, more precisely, their cosets mod $D_n(X)$).

2.1. The Faces of a Singular n -Cube ($n > 0$)

Let $T: I^n \rightarrow X$ be a singular n -cube in X . For $i = 1, 2, \dots, n$, we will define singular $(n - 1)$ -cubes

$$A_i T, B_i T: I^{n-1} \rightarrow X$$

by the formulas

$$A_i T(x_1, \dots, x_{n-1}) = T(x_1, \dots, x_{i-1}, 0, x_i, \dots, x_{n-1}),$$

$$B_i T(x_1, \dots, x_{n-1}) = T(x_1, \dots, x_{i-1}, 1, x_i, \dots, x_{n-1}).$$

$A_i T$ is called the *front i -face* and $B_i T$ is called the *back i -face* of T .

These face operators satisfy the following identities, where $T: I^n \rightarrow X$ is an n -cube, $n > 1$, and $1 \leq i < j \leq n$:

$$\begin{aligned} A_i A_j(T) &= A_{j-1} A_i(T), \\ B_i B_j(T) &= B_{j-1} B_i(T), \\ A_i B_j(T) &= B_{j-1} A_i(T), \\ B_i A_j(T) &= A_{j-1} B_i(T). \end{aligned} \tag{7.2.1}$$

We now define the *boundary operator*; it is a homomorphism $\partial_n : Q_n(X) \rightarrow Q_{n-1}(X)$, $n \geq 1$. To define such a homomorphism, it is only necessary to define it on the basis elements, the singular cubes, by the basic property of free abelian groups. Usually we will write ∂ rather than ∂_n for brevity.

Definition 2.3. For any n -cube T , $n > 0$,

$$\partial_n(T) = \sum_{i=1}^n (-1)^i [A_i T - B_i T].$$

The reader should write out this formula explicitly for the cases $n = 1, 2$, and 3 , and by drawing pictures convince himself that it does in some sense represent the *oriented boundary of an n -cube T* . The following are the two most important properties of the boundary operator:

$$\partial_{n-1}(\partial_n(T)) = 0 \quad (n > 1), \quad (7.2.2)$$

$$\partial_n(D_n(X)) \subset D_{n-1}(X) \quad (n > 0). \quad (7.2.3)$$

The proof of (7.2.2) depends on identities (7.2.1); the proof of (7.2.3) is easy.

As a consequence of (7.2.3), ∂_n induces a homomorphism $C_n(X) \rightarrow C_{n-1}(X)$, which we denote by the same symbol, ∂_n . Note that this new sequence of homomorphisms $\partial_1, \partial_2, \dots, \partial_n, \dots$, satisfies Equation (7.2.2): $\partial_{n-1} \partial_n = 0$.

We now define

$$Z_n(X) = \text{kernel } \partial_n = \{u \in C_n(X) \mid \partial(u) = 0\} \quad (n > 0),$$

$$B_n(X) = \text{image } \partial_{n+1} = \partial_{n+1}(C_{n+1}(X)) \quad (n \geq 0).$$

Note that as a consequence of the equation $\partial_{n-1} \partial_n = 0$, it follows that

$$B_n(X) \subset Z_n(X) \quad \text{for } n > 0.$$

Hence we can define

$$H_n(X) = Z_n(X)/B_n(X) \quad \text{for } n > 0.$$

It remains to define $H_0(X)$ and $H_n(X)$ for $n < 0$, which we will do in a minute. $H_n(X)$ is called the *n -dimensional singular homology group of X* , or the *n -dimensional homology group of X* for short. These groups $H_n(X)$ will be our main object of study. The groups $C_n(X)$, $Z_n(X)$, and $B_n(X)$ are only of secondary importance. More terminology: $Z_n(X)$ is called the *group of n -dimensional singular cycles of X* , or *group of n -cycles*. $B_n(X)$ is called the *group of n -dimensional boundaries* or *group of n -dimensional bounding cycles*.

To define $H_0(X)$, we will first define $Z_0(X)$, then set $H_0(X) = Z_0(X)/B_0(X)$ as before. It turns out that there are actually two slightly different candidates for $Z_0(X)$, which give rise to slightly different groups $H_0(X)$. In some situations one definition is more advantageous, whereas in other situations the other is better. Hence we will use both. The difference between the two is of such a simple nature that no trouble will result.

2.2. First Definition of $H_0(X)$

This definition is very simple. We define $Z_0(X) = C_0(X)$ and

$$H_0(X) = Z_0(X)/B_0(X) = C_0(X)/B_0(X).$$

There is another way we could achieve the same result: we could define $C_n(X) = \{0\}$ for $n < 0$, define $\partial_n: C_n(X) \rightarrow C_{n-1}(X)$ in the only possible way for $n \leq 0$ (i.e., $\partial_n = 0$ for $n \leq 0$), and then define $Z_0(X) = \text{kernel } \partial_0$. More generally, we could then define $Z_n(X) = \text{kernel } \partial_n$ for all integers n , positive or negative, $B_n(X) = \partial_{n-1}(C_{n+1}(X)) \subset Z_n(X)$, and $H_n(X) = Z_n(X)/B_n(X)$ for all n . Of course we then obtain $H_n(X) = \{0\}$ for $n < 0$.

Note that $H_n(X)$ is defined even in case X is empty.

2.3. Second Definition—The Reduced 0-dimensional Homology Group, $\tilde{H}_0(X)$

For this purpose, we define a homomorphism $\varepsilon: C_0(X) \rightarrow \mathbf{Z}$, where \mathbf{Z} denotes the ring of integers. This homomorphism is often called the *augmentation*. Since $C_0(X) = Q_0(X)$ is a free group on the set of 0-cubes, it suffices to define $\varepsilon(T)$ for any 0-cube T in X . The definition is made in the simplest possible nontrivial way: $\varepsilon(T) = 1$. It then follows that if $u = \sum_i n_i T_i$ is any 0-chain, $\varepsilon(u) = \sum_i n_i$ is just the sum of the coefficients. One now proves the following important formula:

$$\varepsilon \circ \partial_1 = 0. \quad (7.2.4)$$

To prove this formula, it suffices to verify that for any singular 1-cube T in X , $\varepsilon(\partial_1(T)) = 0$, and this is a triviality.

We now define $\tilde{Z}_0(X) = \text{kernel } \varepsilon$. Formula (7.2.4) assures us that $B_0(X) \subset \tilde{Z}_0(X)$, hence we can define

$$\tilde{H}_0(X) = \tilde{Z}_0(X)/B_0(X).$$

$\tilde{H}_0(X)$ is called the *reduced 0-dimensional homology group* of X . To avoid some unpleasantness later, we agree to only consider the reduced group $\tilde{H}_0(X)$ in case the space X is nonempty. It is often convenient to set $\tilde{H}_n(X) = H_n(X)$ for $n > 0$.

We will now discuss the relation between the groups $H_0(X)$ and $\tilde{H}_0(X)$. First of all, note that $\tilde{Z}_0(X)$ is a subgroup of $Z_0(X) = C_0(X)$, hence $\tilde{H}_0(X)$ is a subgroup of $H_0(X)$. Let $\xi: \tilde{H}_0(X) \rightarrow H_0(X)$ denote the inclusion homomorphism. Second, from Formula (7.2.4), it follows that $\varepsilon(B_0(X)) = 0$, hence the augmentation ε induces a homomorphism.

$$\varepsilon_*: H_0(X) \rightarrow \mathbf{Z}.$$

Proposition 2.4. *The following sequence of groups and homomorphisms*

$$0 \rightarrow \tilde{H}_0(X) \xrightarrow{\xi} H_0(X) \xrightarrow{\varepsilon_*} \mathbf{Z} \rightarrow 0$$

is exact. Then, we may identify $\tilde{H}_0(X)$ with the kernel of ε_* . (The space X is assumed nonempty.)

The proof is easy. It follows that $H_0(X)$ is the direct sum of $\tilde{H}_0(X)$ and an infinite cyclic subgroup; however, this direct sum decomposition is not natural or canonical; the infinite cyclic summand can often be chosen in many different ways.

Examples

2.1. $X =$ space consisting of a single point. Then we find that

$$\begin{aligned} H_0(X) &\approx \mathbf{Z}, \\ H_n(X) &= \{0\} \quad \text{for } n \neq 0, \\ \tilde{H}_0(X) &= \{0\}. \end{aligned}$$

$\varepsilon_* : H_0(X) \rightarrow \mathbf{Z}$ is an isomorphism.

Proposition 2.6. *Let X be a nonempty arcwise-connected topological space. Then $\varepsilon_* : H_0(X) \rightarrow \mathbf{Z}$ is an isomorphism, and $\tilde{H}_0(X) = \{0\}$.*

To prove this proposition, it suffices to observe that $\varepsilon : C_0(X) \rightarrow \mathbf{Z}$ is an epimorphism, and to prove the $B_0(X) = \text{kernel } \varepsilon$. The details are left to the reader.

Proposition 2.7. *Let X_γ , $\gamma \in \Gamma$, denote the set of arc components of the topological space X . Then the homology group $H_n(X)$ is naturally isomorphic to the direct sum of the groups $H_n(X_\gamma)$ for all $\gamma \in \Gamma$.*

In other words, the n -dimensional homology group of any space is the direct sum of the n -dimensional homology groups of all its arc components.

PROOF. Note that each singular n -cube lies entirely in one of the arc components. Hence, $Q_n(X)$ breaks up naturally into a direct sum:

$$Q_n(X) = \sum_{\gamma \in \Gamma} Q_n(X_\gamma).$$

Similarly, with $D_n(X)$:

$$D_n(X) = \sum_{\gamma \in \Gamma} D_n(X_\gamma);$$

hence on passing to quotient groups we see that

$$C_n(X) = \sum_{\gamma \in \Gamma} C_n(X_\gamma) \quad (\text{direct sum}).$$

Next, note that if a singular n -cube is entirely contained in the arc component X_γ , then its faces are also entirely contained in X_γ . It follows that the boundary $\partial_n : C_n(X) \rightarrow C_{n-1}(X)$ maps $C_n(X_\gamma)$ into $C_{n-1}(X_\gamma)$. Therefore, we have the fol-

lowing direct sum decompositions:

$$Z_n(X) = \sum_{\gamma \in \Gamma} Z_n(X_\gamma),$$

$$B_n(X) = \sum_{\gamma \in \Gamma} B_n(X_\gamma),$$

and hence

$$H_n(X) = \sum_{\gamma \in \Gamma} H_n(X_\gamma). \quad \text{Q.E.D.}$$

Corollary 2.5. *For any topological space X , $H_0(X)$ is a direct sum of infinite cyclic groups, with one summand for each arc component of X . In other words, $H_0(X)$ is a free abelian group whose rank is equal to the number of arc components of X .*

Note that such a simple direct sum theorem does not hold for $\tilde{H}_0(X)$. For example, if X has exactly two arcwise connected components, what is the structure of $\tilde{H}_0(X)$?

EXERCISES

2.1. Determine the structure of the homology group $H_n(X)$, $n \geq 0$, if X is (a) the set of rational numbers with their usual topology. (b) a countable, discrete space.

These example shows the relation between the structure of $H_0(X)$ and certain topological properties of X (the number of arcwise-connected components). In an analogous way, the algebraic structure of the groups $H_n(X)$ for $n > 0$ express certain topological properties of the space X . Naturally, these will be properties of a more subtle nature. One of our principal aims will be to develop methods of determining the structure of the groups $H_n(X)$ for various spaces X .

§3. The Homomorphism Induced by a Continuous Map

Homology theory associates with every topological space X the sequence of groups $H_n(X)$, $n = 0, 1, 2, \dots$. Equally important, it associates with every continuous map $f: X \rightarrow Y$ between spaces a sequence of homomorphisms $f_*: H_n(X) \rightarrow H_n(Y)$, $n = 0, 1, 2, \dots$. Certain topological properties of the continuous map f are reflected in algebraic properties of the homomorphisms f_* . We will now give the definition of f_* , which is very simple.

First of all, we define homomorphisms $f_\#: Q_n(X) \rightarrow Q_n(Y)$ by the simple rule

$$f_\#(T) = fT$$

for any singular n -cube $T: I^n \rightarrow X$, $n = 0, 1, 2, \dots$. We now list the main properties of this homomorphism $f_\#$:

(3.1) If T is a degenerate singular n -cube, so is $f_\#(T)$. Hence $f_\#$ maps $D_n(X)$ into $D_n(Y)$, and induces a homomorphism of $C_n(X)$ into $C_n(Y)$. We will denote this induced homomorphism by the same symbol,

$$f_\# : C_n(X) \rightarrow C_n(Y), \quad n = 0, 1, 2, \dots,$$

to avoid an undue proliferation of notation.

(3.2) The following diagram is commutative for $n = 1, 2, 3, \dots$:

$$\begin{array}{ccc} Q_n(X) & \xrightarrow{f_\#} & Q_n(Y) \\ \downarrow \partial_n & & \downarrow \partial_n \\ Q_{n-1}(X) & \xrightarrow{f_\#} & Q_{n-1}(Y) \end{array}$$

This fact can also be expressed by the equation $\partial_n \circ f_\# = f_\# \circ \partial_n$, or by the statement that $f_\#$ commutes with the boundary operator. [To prove this, one observes that $f_\#(A_i T) = A_i(f_\# T)$ and $f_\#(B_i T) = B_i(f_\#(T))$.] It follows that the following diagram is commutative for $n = 1, 2, 3, \dots$

$$\begin{array}{ccc} C_n(X) & \xrightarrow{f_\#} & C_n(Y) \\ \downarrow \partial_n & & \downarrow \partial_n \\ C_{n-1}(X) & \xrightarrow{f_\#} & C_{n-1}(Y) \end{array}$$

Hence $f_\#$ maps $Z_n(X)$ into $Z_n(Y)$ and $B_n(X)$ into $B_n(Y)$ for all $n \geq 0$ and induces a homomorphism of quotient groups, denoted by

$$f_* : H_n(X) \rightarrow H_n(Y), \quad n = 0, 1, 2, \dots$$

This is our desired definition.

(3.3) The following diagram is also readily seen to be commutative:

$$\begin{array}{ccc} C_0(X) & & \\ \downarrow f_\# & \searrow \varepsilon & \\ & & Z \\ C_0(Y) & \nearrow \varepsilon & \end{array}$$

Hence $f_\#$ also maps $\tilde{Z}_0(X)$ into $\tilde{Z}_0(Y)$ and induces a homomorphism of $\tilde{H}_0(X)$ into $\tilde{H}_0(Y)$ which is denoted by the same symbol:

$$f_* : \tilde{H}_0(X) \rightarrow \tilde{H}_0(Y).$$

The student should verify that the following two diagrams are also commutative:

$$\begin{array}{ccccc}
 \tilde{H}_0(X) & \xrightarrow{\xi} & H_0(X) & & H_0(X) \\
 \downarrow f_* & & \downarrow f_* & & \downarrow f_* \\
 \tilde{H}_0(Y) & \xrightarrow{\xi} & H_0(Y) & & H_0(Y) \\
 & & & & \nearrow \varepsilon_* \\
 & & & & Z
 \end{array}$$

Here the notation is that of Proposition 2.4.

(3.4) Let $f : X \rightarrow X$ denote the identity map. It is easy to verify successively that the following homomorphisms are identity maps:

$$f_{\#} : Q_n(X) \rightarrow Q_n(X),$$

$$f_{\#} : C_n(X) \rightarrow C_n(X),$$

$$f_* : H_n(X) \rightarrow H_n(X),$$

and

$$f_* : \tilde{H}_n(X) \rightarrow \tilde{H}_n(X).$$

Of course, the real interest lies in the fact that f_* is the identity.

(3.5) Let $X, Y,$ and Z be topological spaces, and $g : X \rightarrow Y, f : Y \rightarrow Z$ continuous maps. We will denote by $fg : X \rightarrow Z$ the composition of the two maps. Under these conditions, we have the homomorphisms f_*g_* and $(fg)_*$ from $H_n(X)$ to $H_n(Z)$ for all $n \geq 0$, and from $\tilde{H}_0(X)$ to $\tilde{H}_0(Z)$. We assert that these two homomorphisms are the same in all cases:

$$(fg)_* = f_*g_*.$$

To prove this assertion, one verifies first that $(fg)_{\#}$ and $f_{\#}g_{\#}$ are the same homomorphisms from $Q_n(X)$ to $Q_n(Z)$, then that $(fg)_{\#}$ and $f_{\#}g_{\#}$ are the same homomorphisms from $C_n(X)$ to $C_n(Z)$. From this the assertion follows.

Since Properties (3.4) and (3.5) are so obvious, the reader may wonder why we even bothered to mention them explicitly. These properties will be used innumerable times in the future, and it is in keeping with the customs of modern mathematics to make explicit any axiom or theorem that one uses.

Caution: If $f : X \rightarrow Y$ is a 1-1 map, it does *not* necessarily follow that $f_* : H_n(X) \rightarrow H_n(Y)$ is 1-1; similarly, the fact that f is onto does *not* imply that f_* is onto. There will be plenty of examples to illustrate this point later.

EXERCISES

- 3.1. Let X_{γ} be an arccomponent of X , and $f : X_{\gamma} \rightarrow X$ the inclusion map. Prove that $f_* : H_n(X_{\gamma}) \rightarrow H_n(X)$ is a monomorphism, and the image is the direct summand of $H_n(X)$ corresponding to X_{γ} , as described in Proposition 2.6. Consequence: the direct sum decomposition of Proposition 2.6 can be described completely in terms of such homomorphisms which are induced by inclusion maps.
- 3.2 Let X and Y be spaces havng a finite number of arcwise-connected components, and $f : X \rightarrow Y$ a continuous map. Describe the induced homomorphism $f_* :$

$H_0(X) \rightarrow H_0(Y)$. Generalize to the case where X or Y have an infinite number of arc components.

- 3.3** Let A be a retract of X with retracting map $r: X \rightarrow A$, and let $i: A \rightarrow X$ denote the inclusion map. Prove that $r_*: H_n(X) \rightarrow H_n(A)$ is an epimorphism, $i_*: H_n(A) \rightarrow H_n(X)$ is a monomorphism, and that $H_n(X)$ is the direct sum of the image of i_* and the kernel of r_* .

§4. The Homotopy Property of the Induced Homomorphisms

In this section we will prove a basic property of the homomorphism induced by a continuous map. This property is to a large extent responsible for the distinctive character of a homology theory, and is one of the factors making possible the computation of the homology groups $H_n(X)$ for many spaces X .

Definition 4.1. Two continuous maps $f, g: X \rightarrow Y$ are *homotopic* (notation: $f \simeq g$) if there exists a continuous map $F: I \times X \rightarrow Y$ such that $F(0, x) = f(x)$ and $F(1, x) = g(x)$ for any $x \in X$.

Intuitively speaking, $f \simeq g$ if and only if it is possible to “continuously deform” the map f into the map g . The reader should prove that \simeq is an equivalence relation on the set of all continuous maps from X into Y . The equivalence classes are called *homotopy classes*. The classification of continuous maps into homotopy classes is often very convenient; for example, usually there will be uncountably many continuous maps from X into Y , but if X and Y are reasonable spaces, there will often only be finitely many or countably many homotopy classes.

Theorem 4.2. Let f and g be continuous maps of X into Y . If f and g are homotopic, then the induced homomorphisms, f_* and g_* , of $H_n(X)$ into $H_n(Y)$ are the same. Also, $f_* = g_*: \tilde{H}_0(X) \rightarrow \tilde{H}_0(Y)$.

PROOF. Let $F: I \times X \rightarrow Y$ be a continuous map such that $F(0, x) = f(x)$ and $F(1, x) = g(x)$. We will use the continuous map F to construct a sequence of homomorphisms

$$\varphi_n: C_n(X) \rightarrow C_{n+1}(Y), \quad n = 0, 1, 2, \dots,$$

such that the following relation holds:

$$-f_{\#} + g_{\#} = \partial_{n+1} \circ \varphi_n + \varphi_{n-1} \circ \partial_n, \quad n = 0, 1, 2, \dots \quad (7.4.1)$$

[For $n = 0$, we will interpret this equation as follows: $C_{-1}(X) = C_{-1}(Y) = \{0\}$, ∂_0 is the 0 homomorphism, and $\varphi_{-1}: C_{-1}(X) \rightarrow C_0(Y)$ is (of necessity) the 0 homomorphism.] We assert that the theorem follows immediately from Equation (7.4.1). To see this, let $u \in H_n(X)$; choose a representative cycle $u' \in Z_n(X)$ for the homology class u . Since $\partial_n(u') = 0$, it follows from Equation (7.4.1) that

$$-f_{\#}(u') + g_{\#}(u') = \partial_{n+1}(\varphi_n(u')).$$

Hence, $-f_{\#}(u') + g_{\#}(u') \in B_n(Y)$, and therefore $f_{\#}(u) = g_{\#}(u)$. The proof in case $u \in \tilde{H}_0(X)$ is left to the reader.

This is a typical procedure in algebraic topology; from the continuous map F we construct homomorphisms (algebraic maps) φ_n which reflect properties of F .

To construct the homomorphisms φ_n , we define a sequence of homomorphisms

$$\Phi_n : Q_n(X) \rightarrow Q_{n+1}(Y), \quad n = 0, 1, 2, \dots,$$

as follows. For any singular n -cube $T: I^n \rightarrow X$, define a singular $(n + 1)$ -cube $\Phi_n(T): I^{n+1} \rightarrow Y$ by the formula

$$(\Phi_n T)(x_1, \dots, x_{n+1}) = F(x_1, T(x_2, \dots, x_{n+1})). \quad (7.4.2)$$

We wish to compute $\partial_{n+1} \Phi_n(T)$. For this purpose, observe that

$$\begin{aligned} A_1 \Phi_n(T) &= f_{\#}(T), \\ B_1 \Phi_n(T) &= g_{\#}(T), \\ A_i \Phi_n(T) &= \Phi_{n-1} A_{i-1}(T) \quad (2 \leq i \leq n + 1), \\ B_i \Phi_n(T) &= \Phi_{n-1} B_{i-1}(T) \quad (2 \leq i \leq n + 1). \end{aligned}$$

We now compute:

$$\begin{aligned} \partial_{n+1} \Phi_n(T) &= \sum_{i=1}^{n+1} (-1)^i [A_i \Phi_n(T) - B_i \Phi_n(T)] \\ &= -[f_{\#}(T) - g_{\#}(T)] + \sum_{i=2}^{n+1} (-1)^i \Phi_{n-1}(A_{i-1}(T) - B_{i-1}(T)) \\ &= -f_{\#}(T) + g_{\#}(T) + \sum_{j=1}^n (-1)^{j+1} \Phi_{n-1}(A_j(T) - B_j(T)) \\ &= -f_{\#}(T) + g_{\#}(T) - \Phi_{n-1} \partial_n(T). \end{aligned}$$

Therefore we conclude that for any $u \in Q_n(X)$

$$-f_{\#}(u) + g_{\#}(u) = \partial_{n+1} \Phi_n(u) + \Phi_{n-1} \partial_n(u). \quad (7.4.3)$$

Next, observe that if T is a *degenerate* singular n -cube, $n > 0$, then $\Phi_n(T)$ is a degenerate $(n + 1)$ -cube. Hence

$$\Phi_n(D_n(X)) \subset D_{n+1}(Y)$$

and therefore Φ_n induces a homomorphism

$$\varphi_n : C_n(X) \rightarrow C_{n+1}(Y).$$

From (7.4.3) it follows that φ_n satisfies Equation (7.4.1), as desired. Q.E.D.

Some terminology. The function F above is called a *homotopy* between the continuous maps f and g . The homomorphisms φ_n , $n = 0, 1, 2, \dots$, constitute a *chain homotopy* or *algebraic homotopy* between the *chain maps* $f_{\#}$ and $g_{\#}$.

We will now discuss some applications of Theorem 4.2. Later on when we are able to actually determine the structure of some homology groups and compute some induced homomorphisms, we will be able to use it to prove that certain maps are *not* homotopic. For example, it can be shown that there are infinitely many homotopy classes of maps of an n -sphere onto itself if $n > 0$. For the convenience of the reader, we will repeat some definitions from Chapter II.

4.1. Homotopy Type of Spaces

Definition 4.3. Two spaces X and Y are of the same *homotopy type* if there exist continuous maps $f: X \rightarrow Y$ and $g: Y \rightarrow X$ such that gf is homotopic to the identity map $X \rightarrow X$, and fg is homotopic to the identity map $Y \rightarrow Y$. The maps f and g occurring in this definition are called *homotopy equivalences*.

For example, if X and Y are homeomorphic, then they are of the same homotopy type (but not conversely).

Theorem 4.4. If $f: X \rightarrow Y$ is a homotopy equivalence, then $f_*: H_n(X) \rightarrow H_n(Y)$, $n = 0, 1, 2, \dots$, and $f_*: \tilde{H}_0(X) \rightarrow \tilde{H}_0(Y)$ are isomorphisms.

The proof, which is simple, is left to the reader.

Definition 4.5. A space X is *contractible to a point* if there exists a continuous map $F: I \times X \rightarrow X$ such that $F(0, x) = x$ and $F(1, x) = x_0$ for any $x \in X$ (here x_0 is a fixed point of X).

For example, any convex subset of Euclidean n -space is contractible to a point (proof to be supplied by the reader). If a space X is contractible to a point, then it has the same homotopy type as a space consisting of a single point, and its homology groups are as follows:

$$\begin{aligned} H_0(X) &\approx \mathbf{Z}, & \tilde{H}_0(X) &= 0, \\ H_n(X) &= 0 & \text{for } n &\neq 0. \end{aligned}$$

Definition 4.6. A subset A of a space X is a *deformation retract* of X if there exists a retraction $r: X \rightarrow A$ (i.e., A is a retract of X) and a continuous map $F: I \times X \rightarrow X$ such that $F(0, x) = x$, $F(1, x) = r(x)$ for any $x \in X$.

For example, in Definition 4.5, the set $\{x_0\}$ is a deformation retract of X .

If A is a deformation retract of X , then the inclusion map $i: A \rightarrow X$ is a homotopy equivalence; the proof is left to the reader. Hence, the induced homomorphism $i_*: H_n(A) \rightarrow H_n(X)$ is an isomorphism. This is a useful principle to remember when trying to determine the homology groups of a space.

§5. The Exact Homology Sequence of a Pair

In order to be able to use homology groups effectively, it is necessary to be able to determine their structure for various spaces; so far we can only do this for a few spaces, such as those which are contractible. In most cases, the definition of $H_n(X)$ is useless as a means of computing its structure. In order to make further progress, it seems to be necessary to have some general theorems which give relations between the homology groups of a space X and those of any subspace A contained in X . If $i: A \rightarrow X$ denotes the inclusion map, then there is defined the induced homomorphism $i_*: H_n(A) \rightarrow H_n(X)$ for $n = 0, 1, 2, \dots$. As was mentioned earlier, i_* need not be either an epimorphism or monomorphism.

In this section we will generalize our earlier definition of homology groups, by defining relative homology groups for any pair (X, A) consisting of a topological space X and a subspace A ; these groups are denoted by $H_n(X, A)$, where $n = 0, 1, 2, \dots$. There is a nice relation between these relative homology groups and the homomorphisms $i_*: H_n(A) \rightarrow H_n(X)$, which is expressed by something called the *homology sequence of the pair* (X, A) . Thus, it will turn out that knowledge of the structure of the groups $H_n(X, A)$ will give rise to information about the homomorphisms $i_*: H_n(A) \rightarrow H_n(X)$ and vice versa. In the next section we will take up various properties of the relative homology groups, such as the *excision property*; this will enable us to actually determine these relative homology groups in certain cases.

The relative homology groups are true generalizations of the homology groups defined earlier in the sense that if A is the empty set, then $H_n(X, A) = H_n(X)$. Nevertheless, the primary interest in algebraic topology centers on the nonrelative homology groups $H_n(X)$ for any space X . Our point of view is that the relative groups $H_n(X, A)$ are introduced mainly for the purpose of making possible the computation of the “absolute” homology groups $H_n(X)$, even though in certain circumstances the relative groups are of independent interest.

5.1. The Definition of Relative Homology Groups

Let A be a subspace of the topological space X , and let $i: A \rightarrow X$ denote the inclusion map. It is readily verified that the induced homomorphism $i_\# : C_n(A) \rightarrow C_n(X)$ is a monomorphism, hence we can consider $C_n(A)$ to be a subgroup of $C_n(X)$; it is the subgroup generated by all nondegenerate singular cubes in A . We will use the notation $C_n(X, A)$ to denote the quotient group $C_n(X)/C_n(A)$; it is called the group of n -dimensional chains of the pair (X, A) . The boundary operator $\partial_n: C_n(X) \rightarrow C_{n-1}(X)$ has the property that $\partial_n(C_n(A)) \subset C_{n-1}(A)$, hence, it induces a homomorphism of quotient groups

$$\partial'_n: C_n(X, A) \rightarrow C_{n-1}(X, A)$$

which we will usually denote by ∂_n , or ∂ , for simplicity. In analogy with the definition in §2, we define the group of n -dimensional cycles of (X, A) for $n > 0$ by

$$Z_n(X, A) = \text{kernel } \partial_n = \{u \in C_n(X, A) \mid \partial(u) = 0\}$$

and for $n \geq 0$ the group of n -dimensional bounding cycles by

$$B_n(X, A) = \text{image } \partial_{n+1} = \partial_{n+1}(C_{n+1}(X, A)).$$

Since $\partial_n \partial_{n+1} = 0$, it follows that

$$B_n(X, A) \subset Z_n(X, A)$$

and hence we can define

$$H_n(X, A) = Z_n(X, A)/B_n(X, A).$$

In case $n = 0$, we define $Z_0(X, A) = C_0(X, A)$ and $H_0(X, A) = C_0(X, A)/B_0(X, A)$.

Intuitively speaking, the relative homology group $H_n(X, A)$ is defined in the same way as $H_n(X)$, except that one neglects anything in the subspace A . For example, let $u \in C_n(X)$; then the coset of u in the quotient group, $C_n(X, A)$, is a cycle mod A if and only if $\partial(u) \in C_{n-1}(A)$, i.e., $\partial(u)$ is a chain in the subspace of A .

EXERCISES

- 5.1. Prove that $C_n(X, A)$ is a free abelian group generated by the (cosets of) the nondegenerate singular n -cubes of X which are not contained in A .

It is convenient to display the chain groups $C_n(A)$, $C_n(X)$, and $C_n(X, A)$ together with their boundary operators in one large diagram as follows:

$$\begin{array}{ccccc}
 \vdots & & \vdots & & \vdots \\
 \downarrow & & \downarrow & & \downarrow \\
 C_{n+1}(A) & \xrightarrow{i\#} & C_{n+1}(X) & \xrightarrow{j\#} & C_{n+1}(X, A) \\
 \downarrow & & \downarrow & & \downarrow \\
 C_n(A) & \xrightarrow{i\#} & C_n(X) & \xrightarrow{j\#} & C_n(X, A) \\
 \downarrow & & \downarrow & & \downarrow \\
 C_{n-1}(A) & \xrightarrow{i\#} & C_{n-1}(X) & \xrightarrow{j\#} & C_{n-1}(X, A) \\
 \downarrow & & \downarrow & & \downarrow \\
 \vdots & & \vdots & & \vdots
 \end{array} \tag{7.5.1}$$

Here the vertical arrows denote the appropriate boundary operator, ∂ , and $j_{\#}$ denotes the natural epimorphism of $C_n(X)$ onto its quotient group $C_n(X, A)$. It is clear that each square in this diagram is commutative. In order to avoid having to consider the case $n = 0$ as exceptional, we will define for any integer $n < 0$,

$$C_n(A) = C_n(X) = C_n(X, A) = \{0\}.$$

Thus, this diagram extends infinitely far upward and downward.

As was pointed out in §3, the homomorphisms $i_{\#}$ induce homomorphisms i_* of $H_n(A)$ into $H_n(X)$ for all n . Similarly, the homomorphisms $j_{\#}$ induce homomorphisms

$$j_* : H_n(X) \rightarrow H_n(X, A), \quad n = 0, 1, 2, \dots$$

We will now define a third sequence of homomorphisms

$$\partial_* : H_n(X, A) \rightarrow H_{n-1}(A)$$

for all integral values of n by a somewhat more elaborate procedure, as follows. Let $u \in H_n(X, A)$; we wish to define $\partial_*(u) \in H_{n-1}(A)$. Choose a representative n -dimensional cycle $u' \in C_n(X, A)$ for the homology class u . Because $j_{\#}$ is an epimorphism, we can choose a chain $u'' \in C_n(X)$ such that $j_{\#}(u'') = u'$. Consider the chain $\partial(u'') \in C_{n-1}(X)$; using the commutativity of Diagram (7.5.1) and the fact that u' is a cycle, we see that $j_{\#}\partial(u'') = 0$; hence $\partial(u'')$ actually belongs to the subgroup $C_{n-1}(A)$ of $C_{n-1}(X)$. Also $\partial(u'')$ is easily seen to be a cycle; we define $\partial_*(u)$ to be the homology class of the cycle $\partial(u'')$.

To justify this definition of ∂_* , one must verify that it does not depend on the choice of the representative cycle u' or of the chain u'' such that $j_{\#}(u'') = u'$. In addition, it must be proved that ∂_* is a homomorphism, i.e., $\partial_*(u + v) = \partial_*(u) + \partial_*(v)$. These verifications should be carried out by the reader.

The homomorphism ∂_* is called the *boundary operator of the pair* (X, A) .

It is natural to consider the following infinite sequence of groups and homomorphisms for any pair (X, A) :

$$\cdots \xrightarrow{j_*} H_{n+1}(X, A) \xrightarrow{\partial_*} H_n(A) \xrightarrow{i_*} H_n(X) \xrightarrow{j_*} H_n(X, A) \xrightarrow{\partial_*} \cdots$$

This sequence will be called the *homology sequence of the pair* (X, A) . Once again, in order to avoid having to consider the case $n = 0$ as exceptional, we will make the convention that for $n < 0$, $H_n(A) = H_n(X) = H_n(X, A) = \{0\}$. Thus, the homology sequence of a pair extends to infinity in both the right and left directions.

The following is the main theorem of this section:

Theorem 5.1. *The homology sequence of any pair (X, A) is exact.*

In order to prove this theorem, it obviously suffices to prove the following six inclusion relations:

$$\begin{aligned} \text{image } i_* &\subset \text{kernel } j_*, & \text{image } i_* &\supset \text{kernel } j_*, \\ \text{image } j_* &\subset \text{kernel } \partial_*, & \text{image } j_* &\supset \text{kernel } \partial_*, \\ \text{image } \partial_* &\subset \text{kernel } i_*, & \text{image } \partial_* &\supset \text{kernel } i_*. \end{aligned}$$

We strongly urge the reader to carry out these six proofs, none of which is difficult. It is only by working through such details that one can acquire familiarity with the techniques of this subject.

Proposition 5.2. *Let (X, A) be a pair with A nonempty. Then the boundary operator $\partial_* : H_1(X, A) \rightarrow H_0(A)$ sends $H_1(X, A)$ into the subgroup $\tilde{H}_0(A)$ of $H_0(A)$, and the following sequence is exact:*

$$\cdots \xrightarrow{j_*} H_1(X, A) \xrightarrow{\partial_*} \tilde{H}_0(A) \xrightarrow{i_*} \tilde{H}_0(X) \xrightarrow{j_*} H_0(X, A) \rightarrow 0.$$

This proposition may be paraphrased as follows: If $A \neq \emptyset$, we may replace $H_0(A)$ and $H_0(X)$ by $\tilde{H}_0(A)$ and $\tilde{H}_0(X)$ in the homology sequence of (X, A) , and the resulting sequence will still be exact. The proof of the proposition is left to the reader; it is an interesting exercise.

EXERCISES

5.1. For any pair (X, A) , prove the following assertions:

- $i_* : H_n(A) \rightarrow H_n(X)$ is an isomorphism for all n if and only if $H_n(X, A) = 0$ for all n .
- $j_* : H_n(X) \rightarrow H_n(X, A)$ is an isomorphism for all n if and only if $H_n(A) = 0$ for all n .
- $H_n(X, A) = 0$ for $n \leq q$ if and only if $i_* : H_n(A) \rightarrow H_n(X)$ is an isomorphism for $n < q$ and an epimorphism for $n = q$.

5.2. Let $X_\gamma, \gamma \in \Gamma$, denote the arcwise-connected components of X . Prove that $H_n(X, A)$ is isomorphism to the direct sum of the groups $H_n(X_\gamma, X_\gamma \cap A)$ for all $\gamma \in \Gamma$. Also, determine the structure of $H_0(X_\gamma, X_\gamma \cap A)$. (HINT: There are two cases to consider.)

5.3. For any pair (X, A) , prove there are natural isomorphisms, as follows: Let $Z_n(X \text{ mod } A) = \{x \in C_n(X) \mid \partial(x) \in C_{n-1}(A)\}$. Then

$$Z_n(X, A) \approx Z_n(X \text{ mod } A)/C_n(A),$$

$$B_n(X, A) \approx [B_n(X) + C_n(A)]/C_n(A)$$

$$\approx B_n(X)/[B_n(X) \cap C_n(A)],$$

$$H_n(X, A) \approx Z_n(X \text{ mod } A)/[B_n(X) + C_n(A)].$$

[NOTE: The notation $B_n(X) + C_n(A)$ denotes the least subgroup of $C_n(X)$ which contains both $B_n(X)$ and $C_n(A)$; it need not be isomorphic to their direct sum.]

5.4. Give a discussion of the exact sequence of a pair (X, A) in case the subspace A is empty.

5.5. Let X be a totally disconnected topological space, and let A be an arbitrary subset of X . Determine the various groups and homomorphisms in the homology sequence of (X, A) .

§6. The Main Properties of Relative Homology Group

In order to determine the structure of the relative homology groups of a pair, we need to know the general properties of these newly defined homology groups. First we will consider some properties that are strictly analogous to those discussed in §3 and §4 for “absolute” homology groups.

Let (X, A) and (Y, B) be pairs consisting of a topological space and a subspace. We will say that a continuous function f mapping X into Y is a map of the pair (X, A) into the pair (Y, B) if $f(A) \subset B$; we will use the notation $f : (X, A) \rightarrow (Y, B)$ to indicate that f is such a map.

Our first observation is that any map of pairs $f : (X, A) \rightarrow (Y, B)$ induces a homomorphism $f_* : H_n(X, A) \rightarrow H_n(Y, B)$ of the corresponding relative homology groups. This induced homomorphism is defined as follows.

The continuous map f induces a homomorphism $f_\# : C_n(X) \rightarrow C_n(Y)$ for all n , as described in §3. Since $f(A) \subset B$, it follows that $f_\#$ sends the subgroup $C_n(A)$ into the subgroup $C_n(B)$, and hence there is induced a homomorphism of quotient groups $C_n(X, A) \rightarrow C_n(Y, B)$ which we will also denote by $f_\#$. These induced homomorphisms commute with the boundary operators, in the sense that the following diagram is commutative for each n :

$$\begin{array}{ccc} C_n(X, A) & \xrightarrow{f_\#} & C_n(Y, B) \\ \downarrow \partial & & \downarrow \partial \\ C_{n-1}(X, A) & \xrightarrow{f_\#} & C_{n-1}(Y, B) \end{array}$$

It now follows exactly as in §3 that $f_\#$ induces a homomorphism $f_* : H_n(X, A) \rightarrow H_n(Y, B)$ of the corresponding homology groups for all n .

The reader should formulate and verify the analogs for maps of pairs of the properties described in (7.3.4) and (7.3.5) for maps of spaces.

Note that the homomorphism $j_* : H_n(X) \rightarrow H_n(X, A)$ which is part of the homology sequence of the pair (X, A) (as explained in the preceding section) is actually a homomorphism of the kind we have just described. For, we can consider that the identity map of X into itself defines a map $j : (X, \emptyset) \rightarrow (X, A)$ of pairs, and then it is easily checked that the homomorphism $j_* : H_n(X) \rightarrow H_n(X, A)$ defined in the preceding section is the homomorphism induced by j .

Next, we will consider the homotopy relation for maps of pairs. The appropriate generalization of Definition 4.1 is the following: Two maps $f,$

$g : (X, A) \rightarrow (Y, B)$ are *homotopic* (as maps of pairs) if there exists a continuous map $F : (I \times X, I \times A) \rightarrow (Y, B)$ such that $F(0, x) = f(x)$ and $F(1, x) = g(x)$ for any $x \in X$. The point is that we are requiring that $F(I \times A) \subset B$ in addition to the conditions of Definition 4.1. This additional condition enables one to prove the following result:

Theorem 6.1. *Let $f, g : (X, A) \rightarrow (Y, B)$ be maps of pairs. If f and g are homotopic (as maps of pairs), then the induced homomorphisms f_* and g_* of $H_n(X, A)$ into $H_n(Y, B)$ are the same.*

The proof proceeds along the same lines as that of Theorem 4.2. Because of the stronger hypothesis on the homotopy F , it follows that the homomorphisms φ_n constructed in the proof of Theorem 4.2 satisfy the following condition:

$$\varphi_n(C_n(A)) \rightarrow C_{n+1}(B).$$

Hence, φ_n induces a homomorphism of quotient groups.

$$\varphi_n : C_n(X, A) \rightarrow C_{n+1}(Y, B).$$

The details are left to the reader.

EXERCISES

6.1. Formulate the appropriate definition of two pairs, (X, A) and (Y, B) , being of the same homotopy type, and prove an analog of Theorem 4.4 for such pairs. Similarly, generalize the concepts of retract and deformation retract from spaces to pairs of spaces, and prove the analogs of the properties stated in §3 and §4 for these concepts.

Next, we will consider the effect of a map $f : (X, A) \rightarrow (Y, B)$ on the exact homology sequences of the pairs (X, A) and (Y, B) . We can conveniently arrange the two exact sequences and the homomorphisms induced by f in a ladderlike diagram, as follows:

$$\begin{array}{ccccccccccc}
 \cdots & \longrightarrow & H_n(A) & \xrightarrow{i_*} & H_n(X) & \xrightarrow{j_*} & H_n(X, A) & \xrightarrow{\partial_*} & H_{n-1}(A) & \longrightarrow & \cdots \\
 & & \downarrow & & \downarrow & & \downarrow & & \downarrow & & \\
 \cdots & \longrightarrow & H_n(B) & \xrightarrow{i'_*} & H_n(Y) & \xrightarrow{j'_*} & H_n(Y, B) & \xrightarrow{\partial'_*} & H_{n-1}(B) & \longrightarrow & \cdots
 \end{array} \tag{7.6.1}$$

We assert that *each square of this diagram is commutative*. For the left-hand square and the middle square, this assertion is a consequence of Property (3.5) and its analog for pairs. For the right-hand square, which involves ∂_* and ∂'_* , the assertion of commutativity is the statement of a new property of the homology of pairs. To prove it, one must go back to the basic definitions of

the concepts involved. Since the proof is absolutely straightforward, the details are best left to the reader.

The commutativity of Diagram (7.6.1) helps to give us new insight into the significance of the relative homology groups. From a strictly algebraic point of view, there are usually many different way that we could define groups $H_n(X, A)$ for each integer n in such a way that we would obtain an exact sequence involving the homomorphism $i_* : H_n(A) \rightarrow H_n(X)$ at every third step. The fact that Diagram (7.6.1) is commutative for *any* map f of pairs means that we have chosen a *natural* way to define the groups $H_n(X, A)$ and the exact homology sequence of a pair.

EXERCISES

- 6.2. Let A be an infinite cyclic group and let B be a cyclic group of order n , $n > 1$. How many solutions are there to the following algebraic problem (up to isomorphism): Determine an abelian group G and homomorphisms $\varphi : A \rightarrow G$ and $\psi : G \rightarrow B$ such that the following sequence is exact:

$$0 \rightarrow A \xrightarrow{\varphi} G \xrightarrow{\psi} B \rightarrow 0.$$

We now come to what is perhaps the most important and at the same time the most subtle property of the relative homology groups, called the *excision property*. There is no analogue of this property for absolute homology groups. It will give us some indication as to what the relative homology groups depend on. Ideally, we would like to be able to say that $H_n(X, A)$ depends only on $X - A$, the complement of A in X . While this statement is true under certain rather restrictive hypotheses, in general it is false. Another rough way of describing the situation is to say that *under certain hypotheses*, $H_n(X, A)$ is isomorphic to $H_n(X/A)$ for $n > 0$, and $H_0(X, A) \approx \tilde{H}_0(X/A)$, where X/A denotes the quotient space obtained from X by shrinking the subset A to a point. In any case, the true statement is somewhat weaker.

Theorem 6.2. *Let (X, A) be a pair, and let W be a subset of A such that \overline{W} is contained in the interior A . Then the inclusion map $(X - W, A - W) \rightarrow (X, A)$ induces an isomorphism of relative homology groups:*

$$H_n(X - W, A - W) \approx H_n(X, A), \quad n = 0, 1, 2, \dots$$

The statement of this theorem can be paraphrased as follows: Under the given hypotheses, we can *excise* the set W without affecting the relative homology groups.

The proof of this theorem depends on the fact that in the definition of homology groups we can restrict our consideration to singular cubes which are arbitrarily small, and this will not change anything. For example, if X is a metric space, and ε is a small positive number, we can insist that only singular cubes of diameter less than ε be used in the definition of $H_n(X, A)$ if we wish.

If X is not a metric space, we can prescribe an “order of smallness” by choosing an open covering of X , and then using only singular cubes which are small enough to be contained in a single set of the given open covering. For technical reasons, it is convenient to allow a slightly more general type of covering of X in our definition.

Definition 6.3. Let $\mathcal{U} = \{U_\lambda | \lambda \in \Lambda\}$ be a family of subsets of the topological space X such that *the interiors of the sets U_λ cover X* (we may think of such a family as a generalization of the notion of an open covering of X). A singular n -cube $T: I^n \rightarrow X$ is said to be *small of order \mathcal{U}* if there exists an index $\lambda \in \Lambda$ such that $T(I^n) \subset U_\lambda$.

For example, if X is a metric space and ε is small positive number, we could choose \mathcal{U} to be the covering of X by all spheres of radius ε .

We can now go through our preceding definitions and systematically modify them by allowing only singular cubes which are small of order \mathcal{U} . This procedure works because if $T: I^n \rightarrow X$ is a singular n -cube which is small of order \mathcal{U} , then $\partial_n(T)$ is a linear combination of singular $(n-1)$ -cubes, all of which are also small of order \mathcal{U} .

Notation: $Q_n(X, \mathcal{U})$ denotes the subgroup of $Q_n(X)$ generated by the singular n -cubes which are small of order \mathcal{U} , $D_n(X, \mathcal{U}) = Q_n(X, \mathcal{U}) \cap D_n(X)$, and $C_n(X, \mathcal{U}) = Q_n(X, \mathcal{U})/D_n(X, \mathcal{U})$. Similarly, for any subspace A of X , $Q_n(A, \mathcal{U}) = Q_n(A) \cap Q_n(X, \mathcal{U})$, $D_n(A, \mathcal{U}) = D_n(A) \cap Q_n(A, \mathcal{U})$, and $C_n(A, \mathcal{U}) = Q_n(A, \mathcal{U})/D_n(A, \mathcal{U})$. Finally, for the relative chain groups we let $C_n(X, A, \mathcal{U}) = C_n(X, \mathcal{U})/C_n(A, \mathcal{U})$.

Note that ∂_n maps $Q_n(X, \mathcal{U})$ into $Q_{n-1}(X, \mathcal{U})$, and hence induces homomorphisms

$$C_n(X, \mathcal{U}) \rightarrow C_{n-1}(X, \mathcal{U}),$$

$$C_n(A, \mathcal{U}) \rightarrow C_{n-1}(A, \mathcal{U}),$$

and

$$C_n(X, A, \mathcal{U}) \rightarrow C_{n-1}(X, A, \mathcal{U}),$$

all of which we will continue to denote by the same symbol, ∂_n . Thus, we can define exactly as before

$$Z_n(X, A, \mathcal{U}) = \{u \in C_n(X, A, \mathcal{U}) | \partial_n(u) = 0\},$$

$$B_n(X, A, \mathcal{U}) = \partial_{n+1}(C_{n+1}(X, A, \mathcal{U})).$$

Then since $B_n(X, A, \mathcal{U}) \subset Z_n(X, A, \mathcal{U})$, we can define the homology group

$$H_n(X, A, \mathcal{U}) = Z_n(X, A, \mathcal{U})/B_n(X, A, \mathcal{U}).$$

Notice what happens for $n = 0$: $Q_0(X, \mathcal{U}) = Q_0(X)$, and hence it follows that

$$C_0(X, A, \mathcal{U}) = C_0(X, A),$$

$$Z_0(X, A, \mathcal{U}) = C_0(X, A),$$

$$H_0(X, A, \mathcal{U}) = C_0(X, A)/B_0(X, A, \mathcal{U}).$$

Next, note that the inclusion $Q_n(X, \mathcal{U}) \subset Q_n(X)$ induces homomorphisms

$$\sigma_n : C_n(X, A, \mathcal{U}) \rightarrow C_n(X, A)$$

(actually, σ_n is a monomorphism, although this fact seems to be of no great importance). Obviously, the homomorphism σ commutes with the boundary operator ∂ , i.e., the following diagram is commutative:

$$\begin{array}{ccc} C_n(X, A, \mathcal{U}) & \xrightarrow{\partial} & C_{n-1}(X, A, \mathcal{U}) \\ \downarrow \sigma & & \downarrow \sigma \\ C_n(X, A) & \xrightarrow{\partial} & C_{n-1}(X, A) \end{array}$$

Hence, σ maps $Z_n(X, A, \mathcal{U})$ into $Z_n(X, A)$ and $B_n(X, A, \mathcal{U})$ into $B_n(X, A)$, and thus induces a homomorphism

$$\sigma_* : H_n(X, A, \mathcal{U}) \rightarrow H_n(X, A)$$

for all n .

Theorem 6.4. *Assume that \mathcal{U} satisfies the above hypotheses. Then the induced homomorphisms $\sigma_* : H_n(X, A, \mathcal{U}) \rightarrow H_n(X, A)$ are isomorphism for all n .*

This theorem is the precise formulation of the assertion made earlier that we can restrict our consideration to singular cubes which are small of order \mathcal{U} in defining $H_n(X, A)$. The proof, which is rather long, is given in the next section.

We will now give the proof of Theorem 6.2, the excision property, using Theorem 6.4.

Let (X, A) and W satisfy the conditions of Theorem 6.2. The hypotheses imply that

$$\text{Interior } (A) \cup \text{Interior } (X - W) = X,$$

hence $\mathcal{U} = \{A, X - W\}$ is a generalized open covering of the kind that occurs in Theorem 6.4. Note that for each n ,

$$C_n(X, \mathcal{U}) = C_n(A) + C_n(X - W)$$

by the definition of $C_n(X, \mathcal{U})$ (NOTE: this is *not* a direct sum).

To prove the excision property, consider the following commutative diagram for each integer n :

$$\begin{array}{ccc} C_n(X - W, A - W) & \xrightarrow{1} & C_n(X, A) \\ & \searrow 2 & \uparrow \sigma_n \\ & & C_n(X, A, \mathcal{U}). \end{array} \tag{7.6.2}$$

Each of the homomorphisms indicated in this diagram is induced by an inclusion relation. On passing to homology groups, we obtain the following

commutative diagram:

$$\begin{array}{ccc}
 H_n(X - W, A - W) & \xrightarrow{3} & H_n(X, A) \\
 & \searrow 4 & \uparrow \sigma_* \\
 & & H_n(X, A, \mathcal{U}).
 \end{array} \tag{7.6.3}$$

We wish to prove that the homomorphism indicated by arrow 3 is an isomorphism. Since σ_* is an isomorphism (by Theorem 6.4), it suffices to prove that arrow 4 is an isomorphism. Now the homomorphism designated by arrow 4 is induced by homomorphism designated by arrow 2; therefore let us consider this homomorphism in more detail. By definition,

$$\begin{aligned}
 C_n(X - W, A - W) &= C_n(X - W)/C_n(A - W) \\
 &= C_n(X - W)/[C_n(X - W) \cap C_n(A)]
 \end{aligned}$$

since $C_n(A - W) = C_n(X - W) \cap C_n(A)$. Similarly,

$$\begin{aligned}
 C_n(X, A, \mathcal{U}) &= C_n(X, \mathcal{U})/C_n(A, \mathcal{U}) \\
 &= [C_n(X - W) + C_n(A)]/C_n(A).
 \end{aligned}$$

Thus, the homomorphism denoted by arrow 2 consists of homomorphisms

$$\frac{C_n(X - W)}{C_n(X - W) \cap C_n(A)} \rightarrow \frac{C_n(X - W) + C_n(A)}{C_n(A)} \tag{7.6.4}$$

for $n = 0, 1, 2, \dots$, which are induced by the obvious inclusion relations. But according to the first isomorphism theorem of group theory a homomorphism such as that in (6.4) is an isomorphism. Hence arrow 2 in (6.2) designates an isomorphism, and it follows that the induced homomorphism, arrow 4 in (7.6.3), is also an isomorphism. This completes the proof of Theorem 6.2.

We will give examples of the use of the excision property and other properties of relative homology groups in the next chapter.

§7. The Subdivision of Singular Cubes and the Proof of Theorem 6.4

In this section, we introduce the technique of subdivision of singular cubes and use it to prove Theorem 6.4. Although this technique is based on a rather simple and natural geometric idea, the actual proof is rather long and involved. For that reason it may be advisable to skip this section on a first reading and return to it later.

Actually, we will first prove Theorem 6.4 for the easier case of absolute homology groups (the case where $A = \emptyset$ in the statement of the theorem). The general case will then follow by an easy argument using a purely algebraic proposition called the *five-lemma*.

The first step in the proof of Theorem 6.4 is to introduce the so-called *subdivision operator*, and prove its properties. This will involve some lengthy formulas, tedious verifications, etc. The reader must not let those obscure the essentially simple geometric ideas behind the proof.

First, we will consider the process of subdividing a (singular) cube. Probably the simplest way to subdivide the cube I^n is to divide it into 2^n cubes each of side $\frac{1}{2}$, by means of the hyperplanes $x_i = \frac{1}{2}$, $i = 1, 2, \dots, n$. This leads to the following definitions. Let \mathcal{E}_n denote the set of all vertices of the cube I^n ; an n -tuple of real numbers $e = (e_1, e_2, \dots, e_n)$ belong to \mathcal{E}_n if and only if $e_i = 0$ or 1 for all i . For any singular n -cube $T: I^n \rightarrow X$ and any $e \in \mathcal{E}_n$ define

$$F_e(T): I^n \rightarrow X$$

by

$$(F_e T)(x) = T\left(\frac{1}{2}(x + e)\right) \quad (7.7.1)$$

for all $x = (x_1, \dots, x_n) \in I^n$. Then define $\text{Sd}_n: Q_n(X) \rightarrow Q_n(X)$ by

$$\text{Sd}_n(T) = \sum_{e \in \mathcal{E}_n} F_e(T). \quad (7.7.2)$$

All this is for $n \geq 1$; if T is a singular 0-cube, we define

$$\text{Sd}_0(T) = T.$$

We will now list some properties of the homomorphism Sd_n .

(a) If T is a degenerate cube, then so is $F_e(T)$. Hence Sd_n maps $D_n(X)$ into $D_n(X)$ and induces a homomorphism

$$\text{sd}_n: C_n(X) \rightarrow C_n(X).$$

(b) The homomorphisms Sd_n commute with the boundary operator, i.e.,

$$\partial_n \circ \text{Sd}_n = \text{Sd}_{n-1} \circ \partial_n.$$

In order to prove this, one verifies the following three identities regarding the operators F_e .

(b.1) Assume e and $e' \in \mathcal{E}_n$ are such that $e_i = e'_i$ for $i \neq j$, $e_j = 1$, $e'_j = 0$. Then

$$A_j F_e = B_j F_{e'}.$$

(b.2) Assume $e \in \mathcal{E}_n$, $e_j = 0$, and $e' \in \mathcal{E}_{n-1}$ is defined by

$$e' = (e_1, \dots, e_{j-1}, e_{j+1}, \dots, e_n).$$

Then

$$A_j F_e = F_{e'} A_j.$$

(b.3) Assume $e \in \mathcal{E}_n$, $e_j = 1$, and $e' \in \mathcal{E}_{n-1}$ is defined by

$$e' = (e_1, \dots, e_{j-1}, e_{j+1}, \dots, e_n).$$

Then

$$B_j F_e = F_{e'} B_j.$$

These three identities are exactly what one needs to verify that

$$\partial_n \text{Sd}_n(T) = \text{Sd}_{n-1} \partial_n(T).$$

Naturally, it follows that the induced homomorphism $\text{sd}_n : C_n(X) \rightarrow C_n(X)$ also commutes with the boundary operator.

(c) If $u \in C_0(X) = Q_0(X)$, then $\varepsilon(\text{Sd}_0(u)) = \varepsilon(u)$. This is a triviality, since $\text{Sd}_0 = \text{sd}_0$ is the identity map. We can summarize this property by stating that the operator Sd_0 is *augmentation preserving*.

(d) For any n -chain $u \in C_n(X)$, there exists an integer $q \geq 0$ such that

$$\text{sd}_n^q(u) \in C_n(X, \mathcal{U}),$$

where sd_n^q denotes the homomorphism obtained by q -fold iteration of sd_n . In order to prove this assertion, it suffices to prove that for each singular n -cube $T : I^n \rightarrow X$, there exists an integer $q(T)$ such that $\text{Sd}_n^{q(T)}(T)$ is a sum of cubes which are small of order \mathcal{U} , i.e., such that $\text{Sd}_n^{q(T)}(T) \in Q_n(X, \mathcal{U})$. Then, if u is a linear combination of the singular n -cubes T_1, T_2, \dots, T_k , it suffices to choose q to be the largest of the integers $q(T_1), q(T_2), \dots, q(T_k)$.

To prove that such an integer $q(T)$ exists, consider the open covering of the compact metric space I^n by the inverse images under T of the interiors of the sets of the covering \mathcal{U} ; let ε denote the Lebesgue number¹ of this covering. Then if we choose $q(T)$, so that

$$2^{-q(T)} < \varepsilon/\sqrt{n},$$

the required condition will be satisfied (the \sqrt{n} occurs in the denominator because that is the ratio of the length of the diagonal to the length of the side for an n -dimensional cube).

Next, we are going to define homomorphisms

$$\varphi_n : C_n(X) \rightarrow C_{n+1}(X), \quad n = 0, 1, \dots,$$

such that for any $u \in C_n(X)$,

$$\text{sd}_n(u) - u = \partial_{n+1} \varphi_n(u) + \varphi_{n-1} \partial_n(u). \quad (7.7.3)$$

In the terminology of §4, the φ_n 's are a chain homotopy between the subdivision operator, sd , and the identity map. In order to define φ_n , we first define two auxiliary functions $\eta_0, \eta_1 : I^2 \rightarrow I^1$ by the formulas

$$\eta_0(x_1, x_2) = \frac{x_1}{2 - x_2},$$

$$\eta_1(x_1, x_2) = \begin{cases} \frac{x_1 + 1}{2 - x_2} & \text{if } x_1 + x_2 \leq 1 \\ 1 & \text{if } x_1 + x_2 \geq 1. \end{cases}$$

¹ The Lebesgue number of a covering is defined in a footnote in Chapter II, §5.

To gain a better understanding of η_0 and η_1 , note that η_0 maps the square I^2 onto the interval $[0, 1]$ and that the curves

$$\eta_0(x_1, x_2) = \text{constant}$$

are straight lines through the point $(0, 2)$. Also, η_1 maps the square I^2 onto the interval $[\frac{1}{2}, 1]$, and the curves

$$\eta_1(x_1, x_2) = \text{constant}$$

are straight lines through the point $(-1, 2)$, provided $x_1 + x_2 \leq 1$.

Now for any $e \in \mathcal{E}_e$ and any singular n -cube $T: I^n \rightarrow X$, $n > 0$, define a singular $(n + 1)$ -cube $G_e(T): I^{n+1} \rightarrow X$ by the formula $(G_e T)(x_1, \dots, x_{n+1}) = T(\eta_{e_1}(x_1, x_{n+1}), \eta_{e_2}(x_2, x_{n+1}), \dots, \eta_{e_n}(x_n, x_{n+1}))$. Define

$$\Phi_n: Q_n(X) \rightarrow Q_{n+1}(X), \quad n > 0,$$

by

$$\Phi_n(T) = (-1)^{n+1} \sum_{e \in \mathcal{E}_n} G_e(T).$$

We will complete the definition by defining $\Phi_0: Q_0(X) \rightarrow Q_1(X)$ to be the zero map. The motivation for the definition of Φ_n is indicated in Figure 7.1 for the case $n = 1$. We will now prove some properties of the homomorphisms Φ_n .

(e) If T is a degenerate cube, then so is $G_e(T)$. Hence Φ_n maps $D_n(X)$ into $D_{n+1}(X)$ and induces the desired homomorphism

$$\varphi_n: C_n(X) \rightarrow C_{n+1}(X), \quad n = 0, 1, \dots$$

(f) For any singular n -cube $T: I^n \rightarrow X$, we have

$$\partial_{n+1} \Phi_n(T) = \text{Sd}_n(T) - T - \Phi_{n-1} \partial_n(T) + \text{degenerate cubes.} \quad (7.7.4)$$

Equation (7.7.3) follows from this. Of course Formula (7.7.4) is a triviality if $n = 0$. Therefore, we will concentrate on the case $n > 0$. To compute $\partial_{n+1} \Phi_n(T)$, one needs the following identities:

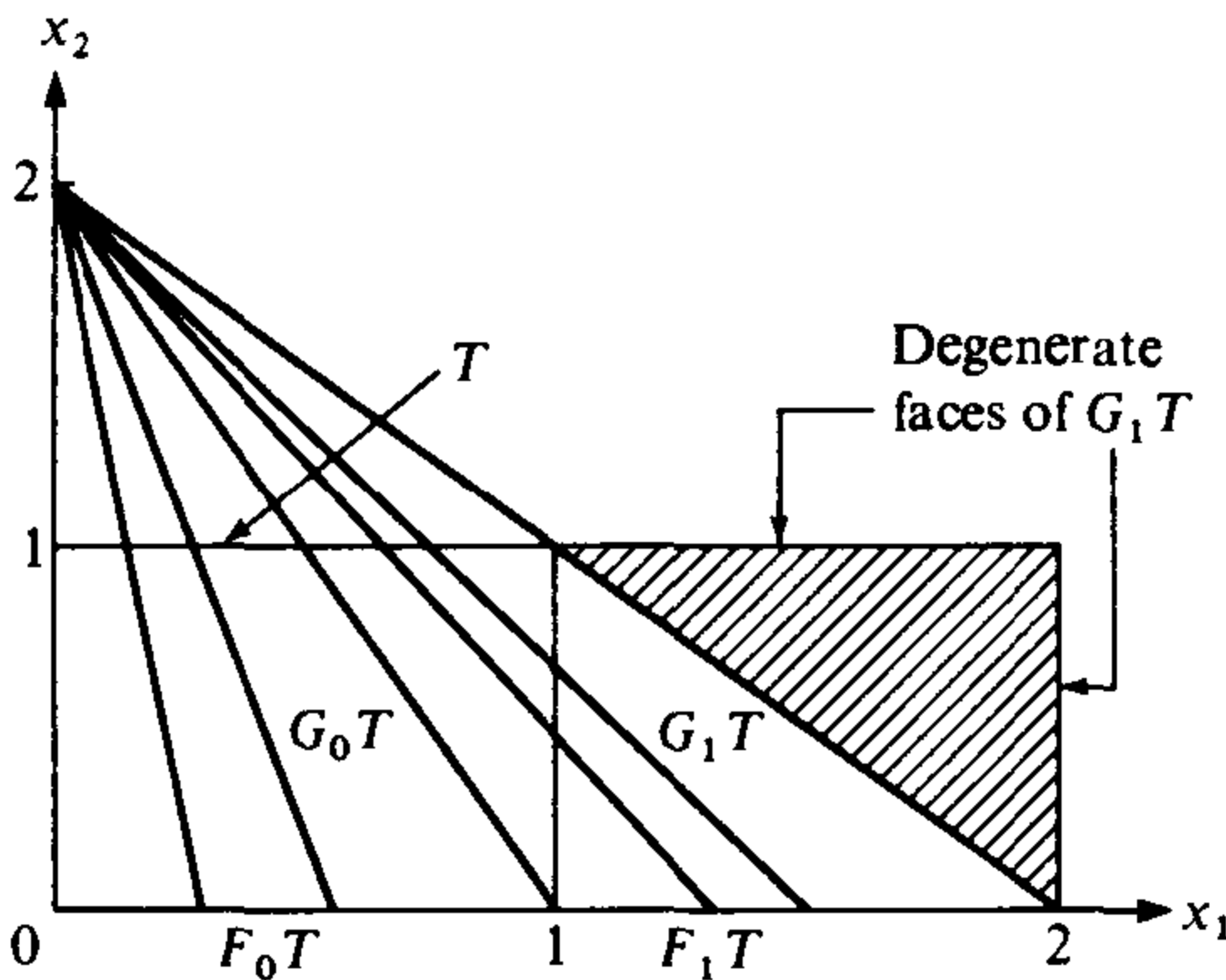

FIGURE 7.1

(f.1) $A_{n+1}G_e(T) = F_e(T)$.

(f.2) $B_{n+1}G_e(T) = T$ if $e = (0, 0, \dots, 0)$ and $B_{n+1}G_e(T)$ is a degenerate cube otherwise.

(f.3) Assume $e, e' \in \mathcal{E}_n, j \leq n, e_j = 1, e'_j = 0$, and $e_i = e'_i$ for all $i \neq j$. Then

$$A_jG_e(T) = B_jG_{e'}(T)$$

for any n -cube T .

(f.4) Assume $e \in \mathcal{E}_n, n \geq 2$, and $e' \in \mathcal{E}_{n-1}$ is defined by

$$e' = (e_1, \dots, e_{j-1}, e_{j+1}, \dots, e_n), \quad j \leq n.$$

If $e_j = 0$, then

$$A_jG_e(T) = G_{e'}A_j(T),$$

whereas if $e_j = 1$, then

$$B_jG_e(T) = G_{e'}B_j(T).$$

In case $n = 1$, A_1G_0T and B_1G_1T are degenerate.

By using Identities (f.1)–(f.4), it is a straightforward matter to verify Formula (7.7.4) and hence (7.7.3).

(g) If $u \in C_n(X, \mathcal{U})$, then $\varphi_n(u) \in C_{n+1}(X, \mathcal{U})$ also. To prove this, observe that if a cube T is small of order \mathcal{U} , then so is $G_e(T)$. Hence $\Phi_n(T) \in Q_{n+1}(X, \mathcal{U})$, and φ_n has the required property.

We have now defined the operators sd_n and φ_n , and proved their principal properties. For the sake of simplicity, we will write sd rather than sd_n and φ rather than φ_n from now on.

We also need the following formulas. For any integer $q > 0$, define

$$\psi_q : C_n(X) \rightarrow C_{n+1}(X), \quad n = 0, 1, 2, \dots,$$

by

$$\psi_q(u) = \sum_{i=0}^{q-1} \varphi(\text{sd}^i u).$$

The following equation now readily follows from Equation (7.7.3):

$$\text{sd}^q(u) - u = \partial\psi_q(u) + \psi_q\partial(u). \quad (7.7.5)$$

Note that statement (g) leads to the following.

(g') If $u \in C_n(X, \mathcal{U})$, then $\psi_q(u) \in C_{n+1}(X, \mathcal{U})$ for any integer $q > 0$.

With these preliminaries out of the way, we can now prove directly that

$$\sigma_* : H_n(X, \mathcal{U}) \rightarrow H_n(X)$$

is an isomorphism.

First, we prove that σ_* is an epimorphism. Let $x \in H_n(X)$; we will prove there exists an element $y \in H_n(X, \mathcal{U})$ such that $\sigma_*(y) = x$. Let $u \in C_n(X)$ be a representative cycle for x . By Statement (d), there exists an integer q such that

$$\text{sd}^q(u) \in C_n(X, \mathcal{U}).$$

Since u is a cycle and sd commutes with the boundary operator, it follows that $sd^q(u)$ is also a cycle. If we apply Equation (7.7.5), we see that u and $sd^q(u)$ belong to the same homology class. Let y be the homology class of $sd^q(u)$ in $H_n(X, \mathcal{U})$. Then $\sigma_*(y) = x$, as desired.

Next, we will prove that σ_* is a monomorphism. Assume $x \in H_n(X, \mathcal{U})$ and $\sigma_*(x) = 0$. We will show that $x = 0$. Let $v \in C_n(X, \mathcal{U})$ be a representative cycle for x . Since $\sigma_*(x) = 0$, there exists an element $u \in C_{n+1}(X)$ such that

$$\partial(u) = v.$$

Apply Statement (d) to obtain an integer q such that

$$sd^q(u) \in C_{n+1}(X, \mathcal{U}).$$

Now apply Equation (7.7.5),

$$sd^q(u) - u = \partial\psi_q(u) + \psi_q(v).$$

Apply the boundary operator to both sides to obtain

$$\partial(sd^q u) - v = \partial\psi_q(v)$$

or

$$v = \partial(sd^q u - \psi_q(v)).$$

Since $v \in C_n(X, \mathcal{U})$, $\psi_q(v) \in C_{n+1}(X, \mathcal{U})$ by Statement (g'). Thus,

$$sd^q u - \psi_q(v) \in C_{n+1}(X, \mathcal{U})$$

and hence v is the boundary of a chain which is small of order \mathcal{U} . Therefore, $x = 0$.

This completes the proof of Theorem 6.4 in the case $A = \emptyset$.

Next, we will prove Theorem 6.4 in the general case, where A is an arbitrary subset of X . Observe that for each integer n we have the following commutative diagram:

$$\begin{array}{ccccccccc} 0 & \longrightarrow & C_n(A, \mathcal{U}) & \longrightarrow & C_n(X, \mathcal{U}) & \longrightarrow & C_n(X, A, \mathcal{U}) & \longrightarrow & 0 \\ & & \downarrow \sigma'' & & \downarrow \sigma' & & \downarrow \sigma & & \\ 0 & \longrightarrow & C_n(A) & \xrightarrow{i_*} & C_n(X) & \xrightarrow{j_*} & C_n(X, A) & \longrightarrow & 0 \end{array}$$

Both of the rows in this diagram are exact sequences of chain groups. On passing to the corresponding homology groups, we obtain the following ladderlike diagram involving two long exact sequences:

$$\begin{array}{ccccccccc} \longrightarrow & H_{n+1}(X, A, \mathcal{U}) & \longrightarrow & H_n(A, \mathcal{U}) & \longrightarrow & H_n(X, \mathcal{U}) & \longrightarrow & H_n(X, A, \mathcal{U}) & \longrightarrow & \cdots \\ & \downarrow \sigma_* & & \downarrow \sigma''_* & & \downarrow \sigma'_* & & \downarrow \sigma_* & & \\ \longrightarrow & H_{n+1}(X, A) & \xrightarrow{\partial_*} & H_n(A) & \xrightarrow{i_*} & H_n(X) & \xrightarrow{j_*} & H_n(X, A) & \longrightarrow & \cdots \end{array}$$

Each square in this diagram is commutative; the proof of this fact is exactly the same as the proof of the commutativity of Diagram (7.6.1). By what we have already proved, the homomorphisms σ'_* and σ''_* are isomorphisms. It now follows from the so-called *five-lemma* that the homomorphism σ_* is also an isomorphism, as was to be proved.

It remains to state and prove the *five-lemma*:

Lemma 7.1. *Consider the following diagram of abelian groups and homomorphisms.*

$$\begin{array}{ccccccccc}
 A_1 & \xrightarrow{i_1} & A_2 & \xrightarrow{i_2} & A_3 & \xrightarrow{i_3} & A_4 & \xrightarrow{i_4} & A_5 \\
 \downarrow f_1 & & \downarrow f_2 & & \downarrow f_3 & & \downarrow f_4 & & \downarrow f_5 \\
 B_1 & \xrightarrow{j_1} & B_2 & \xrightarrow{j_2} & B_3 & \xrightarrow{j_3} & B_4 & \xrightarrow{j_4} & B_5
 \end{array}$$

Assume that each row is exact, that each square is commutative, that f_1 is an epimorphism, f_2 and f_4 are isomorphisms, and f_5 is a monomorphism. Then f_3 is also an isomorphism.

PROOF. It suffices to prove the following two assertions:

- (a) For any $x \in A_3$, if $f_3(x) = 0$ then $x = 0$.
- (b) Given any $x \in B_3$, there exists an element $y \in A_3$ such that $f_3(y) = x$.

The proof of each of these two assertions is carried out by a technique called “diagram chasing.” For the reader who has seen this technique used before, the proof of this lemma will be very easy. For those who are unfamiliar with the technique, the proof of this lemma is an ideal exercise, and such readers are urged to work out the details of the proof. The proof of a proposition such as the five-lemma by diagram chasing requires practically no cleverness or ingenuity. At each stage of the proof there is only one possible “move”; one does not have to make any choices.

NOTES

The reader may have wondered why we singled out certain properties of homology theory and called them “basic.” The choice of these particular properties is essentially due to the work of S. Eilenberg and N. E. Steenrod. In the 1940s they developed an axiomatic approach to homology theory. Their ideas were announced in 1945 in a short note in Volume 31 of the *Proceedings of the National Academy of Sciences* and developed in a well-known book (entitled *Foundations of Algebraic Topology*) published in 1952. They intended to publish a second volume explaining more of their ideas, but unfortunately this project was never completed.

This work of Eilenberg and Steenrod was very influential and greatly advanced our understanding of homology theory. Subsequent developments

in algebraic topology, especially the introduction and use of what are called “extraordinary” homology and cohomology theories, have added further justification to the choices that Eilenberg and Steenrod made back in 1945.

Apparently exact sequences were introduced into algebraic topology by Witold Hurewicz in 1941 [see *Bull. Am. Math. Soc.*, **47** (1941), 562–563]. Seldom in the history of mathematics has a new definition had such happy consequences as the definition of an exact sequence! For some mysterious reason exact sequences seem to be ubiquitous in algebraic topology; we will see more examples in the later chapters of this book. They are also of frequent occurrence in several other parts of mathematics. Exact sequences often occur in a pattern similar to the exact sequence of a pair, as in Theorem 5.1 of this chapter, so that the simple statement that such-and-such a sequence is exact is equivalent to six inclusion relations between various images and kernels.

CHAPTER VIII

Determination of the Homology Groups of Certain Spaces: Applications and Further Properties of Homology Theory

§1. Introduction

In this chapter, we will actually determine the homology groups of various spaces: the n -dimensional sphere, finite graphs, and compact 2-dimensional manifolds. We also use homology theory to prove some classical theorems of topology, most of which are due to L.E.J. Brouwer. In addition, we prove some more basic properties of homology groups.

§2. Homology Groups of Cells and Spheres—Applications

We will now use the exact homology sequence and the excision property to determine the homology groups of a noncontractible space, namely, the n -sphere

$$S^n = \{x \in \mathbf{R}^{n+1} \mid |x| = 1\}.$$

This example is not only interesting in its own right; it is also basic to much that follows.

Theorem 2.1. *For any integer $n \geq 0$,*

$$\tilde{H}_i(S^n) = \begin{cases} \mathbf{Z} & \text{if } i = n \\ \{0\} & \text{if } i \neq n. \end{cases}$$

Hence

$$H_0(S^n) = \begin{cases} \mathbf{Z} \oplus \mathbf{Z} & \text{if } n = 0 \\ \mathbf{Z} & \text{if } n > 0. \end{cases}$$

It is clear that the second statement is equivalent to the first statement for $i = 0$, in view of the relation between reduced and nonreduced homology groups.

PROOF OF THEOREM 2.1. The proof is by induction on n . The theorem is true for $n = 0$, because S^0 is a space consisting of exactly two points. In order to make the inductive step, we will identify S^n with the “equator” of S^{n+1} , i.e.,

$$S^n = \{x = (x_1, \dots, x_{n+2}) \in S^{n+1} \mid x_{n+2} = 0\}.$$

We also need to consider the following two subsets of S^{n+1} :

$$E_+^{n+1} = \{(x_1, \dots, x_{n+2}) \in S^{n+1} \mid x_{n+2} \geq 0\},$$

$$E_-^{n+1} = \{(x_1, \dots, x_{n+2}) \in S^{n+1} \mid x_{n+2} \leq 0\}.$$

These may be referred to as the upper and lower hemispheres of S^{n+1} . These hemispheres are obviously homeomorphic to the set

$$E_+^{n+1} = \{(x_1, \dots, x_{n+2}) \in R^{n+2} \mid |x| \leq 1 \text{ and } x_{n+2} = 0\},$$

hence they are contractible. The reader should draw a picture illustrating these sets for the case $n = 1$. Now consider the following diagram of homology groups:

$$\tilde{H}_i(S^n) \xleftarrow{\partial_*} H_{i+1}(E_-^{n+1}, S^n) \xrightarrow{k_*} H_{i+1}(S^{n+1}, E_+^{n+1}) \xleftarrow{j_*} \tilde{H}_{i+1}(S^{n+1}).$$

In this diagram, $j : S^{n+1} \rightarrow (S^{n+1}, E_+^{n+1})$ and $k : (E_-^{n+1}, S^n) \rightarrow (S^{n+1}, E_+^{n+1})$ denote inclusion maps. Consideration of the homology sequence of the pair (E_-^{n+1}, S^n) shows that ∂_* is an isomorphism, because E_-^{n+1} is contractible; similarly, it follows from the exactness of the homology sequence of the pair (S^{n+1}, E_+^{n+1}) and the contractibility of E_+^{n+1} that j_* is an isomorphism. To complete the proof, it suffices to prove that k_* is an isomorphism. Now the pair (E_-^{n+1}, S^n) is obtained from the pair (S^{n+1}, E_+^{n+1}) by excising the set $E_+^{n+1} - S^n$. However, we can not invoke the excision property (Theorem II.6.2) because the closure of $E_+^{n+1} - S^n$ is not contained in the interior of E_+^{n+1} . There is a way around this difficulty, however. Let

$$W = \{(x_1, \dots, x_{n+2}) \in S^{n+1} \mid x_{n+2} \geq \frac{1}{2}\}.$$

Now consider the following diagram:

$$\begin{array}{ccc} H_{i+1}(E_-^{n+1}, S^n) & \xrightarrow{k_*} & H_{i+1}(S^{n+1}, E_+^{n+1}) \\ & \searrow h_* & \nearrow e_* \\ & & H_{i+1}(S^{n+1} - W, E_+^{n+1} - W) \end{array}$$

Here the symbols e and h denote inclusion maps. This diagram is obviously commutative. Now we can invoke the excision property to conclude that e_* is an isomorphism. Moreover, h_* is also an isomorphism because the map h is a homotopy equivalence of pairs; there is an obvious deformation retraction

of the pair $(S^{n+1} - W, E_+^{n+1} - W)$ onto the pair (E_-^{n+1}, S^n) . It follows from the commutativity of the diagram that k_* is also an isomorphism, as desired.

Q.E.D.

This proof illustrates the strategy that frequently has to be employed in applying the excision property. The situation is reminiscent of that often encountered in trying to apply the Seifert–Van Kampen theorem to determine the structure of the fundamental group of a space.

In §5 we will indicate an alternative proof of this theorem using the Mayer–Vietoris sequence.

We will now state some applications and corollaries of this result.

Proposition 2.2. *The sphere S^n is not contractible to a point.*

For the statement of the next two propositions, we will use the notation E^n to denote the set $\{x \in \mathbf{R}^n \mid |x| \leq 1\}$, called the unit *disc* or *ball* in \mathbf{R}^n (the proofs are left to the reader).

Proposition 2.3. *S^n is not a retract of E^{n+1} .*

Proposition 2.4. *The relative homology groups of the pair (E^n, S^{n-1}) are as follows (for $n \geq 1$)*

$$H_i(E^n, S^{n-1}) = \begin{cases} 0, & i \neq n \\ \mathbf{Z}, & i = n. \end{cases}$$

Proposition 2.5 (Brouwer fixed-point theorem). *Any continuous map $f: E^n \rightarrow E^n$ has at least one fixed point, i.e., a point x such that $f(x) = x$.*

PROOF. Assume to the contrary that $f(x) \neq x$ for all $x \in E^n$. Then the two distinct points x and $f(x)$ determine a unique straight line which intersects S^{n-1} in two points. Let $v(x)$ denote that point of the intersection which is such that x is between $v(x)$ and $f(x)$, or x is equal to $v(x)$. Then v is a map of E^n onto S^{n-1} . It is a nice technical exercise for the student to prove that v is continuous. It is obvious from the definition that v is a retraction. But this contradicts Proposition 2.3. Q.E.D.

For a discussion of the significance of the Brouwer fixed-point theorem, see Chapter II, §6.

We will use the knowledge we have gained about the homology groups of S^n to study continuous maps of S^n into itself. Let $f: S^n \rightarrow S^n$ be such a continuous map; consider the induced homomorphism

$$f_*: \tilde{H}_n(S^n) \rightarrow \tilde{H}_n(S^n).$$

Since $\tilde{H}_n(S^n)$ is an infinite cyclic group, there exists a unique integer d such

that $f_*(u) = du$ for any $u \in \tilde{H}_n(S^n)$. This integer d is called the *degree* of f . It has the following basic properties:

(a) It is a homotopy invariant, i.e., if f_0 and f_1 are homotopic maps of S^n into itself, then f_0 and f_1 have the same degree. This fact is a direct consequence of the homotopy property of the induced homomorphism. It is proved in books on homotopy theory that the converse statement is also true, i.e., if f_0 and f_1 have the same degree, then they are homotopic.

(b) The degree of the composition of two maps is the product of the degrees. To be precise, if f and g are continuous maps $S^n \rightarrow S^n$, then $\text{degree}(gf) = (\text{degree } g)(\text{degree } f)$.

Given any map $f: S^n \rightarrow S^n$, we will define a new map $\Sigma f: S^{n+1} \rightarrow S^{n+1}$, called the *suspension* of f by the following formula:

$$(\Sigma f)(x_1, x_2, \dots, x_{n+2}) = \begin{cases} (0, \dots, 0, x_{n+2}) & \text{if } |x_{n+2}| = 1 \\ \left(tf\left(\frac{x_1}{t}, \dots, \frac{x_{n+1}}{t}\right), x_{n+2} \right) & \text{if } |x_{n+2}| < 1. \end{cases}$$

where $t = (1 - x_{n+2}^2)^{1/2}$. The geometric idea behind this formula may be described as follows: Σf maps the north pole of S^{n+1} to the north pole, the south pole of S^{n+1} to the south pole, and the equator into the equator according to the given map f . The meridian of S^{n+1} through the point x on the equator is mapped homeomorphically onto the meridian through the point $f(x)$.

(c) The degree of the suspension, Σf , is the same as that of the original map f . The proof of this property is left to the reader; it depends on the diagram used to prove Theorem 2.1 and the following two inclusions:

$$(\Sigma f)(E_+^{n+1}) \subset E_+^{n+1} \quad \text{and} \quad (\Sigma f)(E_-^{n+1}) \subset E_-^{n+1}.$$

In order to make use of this notion of degree, it is necessary to know the degree of certain explicit maps. The following are some propositions along this line. The proofs are left to the reader as exercises for the most part.

(d) The degree of the identity map is $+1$.

(e) The degree of a constant map is 0 .

(f) Any map $f: S^0 \rightarrow S^0$ has degree ± 1 or 0 .

(g) Let $v: S^n \rightarrow S^n$ denote the map which is reflection in a hyperplane through the origin of \mathbf{R}^{n+1} ; then v has degree -1 . To prove this, note first of all that we may choose our coordinate system so that the hyperplane in question has the equation $x_{n+1} = 0$. Then using the suspension, it is easy to prove this formula by induction on n , starting with the case $n = 0$.

(h) Let $f: S^n \rightarrow S^n$ denote the antipodal map, defined by $f(x) = -x$. Then the degree of f is $(-1)^{n+1}$. (HINT: Represent f as a composition of reflections.)

(i) Let $f: S^n \rightarrow S^n$ be a map which is fixed point free, i.e., $f(x) \neq x$ for all x . Then f is homotopic to the antipodal map, and hence has degree $(-1)^{n+1}$.

We will now use these facts to discuss the existence of continuous tangent vector fields on S^n . By a *tangent vector field* on S^n we mean a function v which

assigns to each point $x \in S^n$ a vector $v(x)$ which is tangent to S^n at the point x . The tangency condition means that the vector $v(x)$ must be perpendicular to the unit vector x for all $x \in S^n$. The vector field v is said to be continuous (or differentiable) if the components of v are continuous (or differentiable) real-valued functions. When we speak of a *nonzero* vector field v , we mean that $v(x) \neq 0$ for *all* $x \in S^n$. The main theorem about such vector fields is the following:

Theorem 2.6. *There exists a continuous nonzero tangent vector field on S^n if and only if n is odd.*

It is easy to give an example of a continuous nonzero tangent vector field on S^n for n odd: One defines

$$v(x_1, \dots, x_{n+1}) = (-x_2, x_1, -x_4, x_3, \dots, -x_{n+1}, x_n).$$

To prove that such a vector field does not exist on S^n for n even, one proves the following statement: If there exists a continuous nonzero tangent vector field v on S^n , then the identity map of S^n onto itself is homotopic to a fixed-point-free map $f: S^n \rightarrow S^n$. In fact, one may define f by the formula

$$f(x) = \frac{x + v(x)}{|x + v(x)|}$$

and the homotopy by

$$f_t(x) = \frac{x + tv(x)}{|x + tv(x)|}, \quad 0 \leq t \leq 1.$$

Theorem 2.6 now follows from this statement and Property (i) above.

Later on we will prove that there exist maps $S^n \rightarrow S^n$ of every possible degree provided $n \geq 1$.

The discussion of the degree of a map that we have just given applies only to maps of S^n into itself. These considerations may be extended to a slightly more general situation as follows. Let X and Y be topological spaces which are homeomorphic to S^n ($n \geq 1$) or more generally, have the same homotopy type as S^n . Then $H_n(X)$ and $H_n(Y)$ are infinite cyclic groups; hence there are two different choices possible for a generator of each of these groups. If definite choices of a generator have been made in each case, we will say that the spaces X and Y have been *oriented*. Assume that the chosen generators are denoted by $x \in H_n(X)$ and $y \in H_n(Y)$, respectively. Let $f: X \rightarrow Y$ be a continuous map; then there exists a unique integer d such that $f_*(x) = dy$. This integer d is called the *degree* of f . Note that changing the orientation of either X or Y changes the sign of the degree. It is a homotopy invariant of f , and has properties analogous to those discussed above.

Examples

2.1. Let $X = S^1$ and $Y = \mathbf{R}^2 - \{0\}$. We leave it to the reader to prove that S^1 is a deformation retract of $\mathbf{R}^2 - \{0\}$. A continuous map $S^1 \rightarrow \mathbf{R}^2 - \{0\}$ may be interpreted as a closed, continuous curve in the plane \mathbf{R}^2 which does not pass through the origin. The degree of such a map is essentially the same thing as the winding number of the closed path around the origin, as described in books on analysis.

Definition 2.7. Let X be a Hausdorff space and $x \in X$. The group $H_n(X, X - \{x\})$ is called the *n-dimensional local homology group of X at x* .

If N is any neighborhood of x in X , then it follows easily from the excision property that $H_n(N, N - \{x\}) \approx H_n(X, X - \{x\})$. Thus, the local homology groups of X at x only depend on arbitrarily small neighborhoods of x in X , hence the name. Examples and properties of these local homology groups are given in the exercises.

EXERCISES

- 2.1.** Prove that S^{n-1} is a deformation retract of $\mathbf{R}^n - \{0\}$.
- 2.2.** Prove that the complement of a point in S^n is homeomorphic to \mathbf{R}^n (stereographic projection).
- 2.3.** Prove by two different methods that \mathbf{R}^m and \mathbf{R}^n are not homeomorphic if $m \neq n$:
(a) Prove that their Alexandroff 1-point compactifications are not homeomorphic, and (b) prove that the complement of a point in \mathbf{R}^m is not homeomorphic to the complement of a point in \mathbf{R}^n .
- 2.4.** Prove that any homeomorphism h of E^n onto itself maps S^{n-1} onto S^{n-1} . (HINT: Consider the complement of a point.)
- 2.5.** Let $f: S^n \rightarrow S^n$ be a continuous map whose degree is nonzero. Prove that f maps S^n onto S^n .
- 2.6.** Let X be a Hausdorff space, $x \in X$, and assume x has a closed, contractible neighborhood N with boundary B such that B is a deformation retract of $N - \{x\}$. Prove that the local homology group $H_n(X, X - \{x\})$ is isomorphic to $\tilde{H}_{n-1}(B)$. (NOTE: This often gives a practical method for determining local homology groups of reasonably nice spaces.)
- 2.7.** Determine the local homology groups at various points of the closed n -dimensional ball, E^n . Use this computation to give another solution of Exercise 2.4.
- 2.8.** Use local homology groups to prove that an n -dimensional and an m -dimensional manifold are not homeomorphic if $m \neq n$.
- 2.9.** Prove that a Möbius strip is *not* homeomorphic to the annulus $\{x \in \mathbf{R}^2 \mid 1 \leq |x| \leq 2\}$, although they have the same homotopy type and both are compact.

(SUGGESTION: As a first step, determine local homology groups at various points of both spaces.)

§3. Homology of Finite Graphs

In this section we will use the properties of relative homology groups to develop a systematic procedure for computing the homology groups of a rather simple type of topological space called a graph. The results obtained are not very profound; however, they are illustrative of the techniques we will use later to determine the homology groups of more general spaces.

Definition 3.1. A *finite, regular graph* (or just a *graph* for short) is a pair consisting of a Hausdorff space X and a finite subspace X^0 (points of X^0 are called *vertices*) such that the following conditions hold:

- (a) $X - X^0$ is the disjoint union of a finite number of open subsets e_1, e_2, \dots, e_k , called *edges*. Each e_i is homeomorphic to an open interval of the real line.
- (b) The point set boundary, $\bar{e}_i - e_i$, of the edge e_i consists of two distinct vertices, and the pair (\bar{e}_i, e_i) is homeomorphic to the pair $([0, 1], (0, 1))$.

One could also consider infinite graphs, and nonregular graphs, i.e., those for which $\bar{e}_i - e_i$ may consist of one *or* two vertices. However, we will not do this for the present.

Note that a graph is compact, since it is the union of a finite number of compact subsets (the closed edges \bar{e}_i and the vertices). It may be either connected or disconnected, and it may have isolated vertices. If a vertex v belongs to the closure of an edge e_i , it is customary to say that e_i and v are *incident*.

It is easy to give many examples of graphs. It can be shown that every graph, as defined here, can be embedded homeomorphically in Euclidean 3-space, and many can be embedded in the plane. A famous theorem of Kuratowski (1920) gives necessary and sufficient conditions for a graph to be embeddable in the plane.

If a space X can be given a structure of a graph by specifying a set of vertices X^0 then we can specify additional graph structures on X by *subdividing*, i.e., inserting additional vertices (provided the set of edges is nonempty).

We will now show how to determine the structure of the homology groups of a graph X . First, we will determine the relative homology groups of the pair (X, X^0) and then use the exact homology sequence of (X, X^0) to achieve our goal. Let e_1, e_2, \dots, e_k denote the edges of the given graph (X, X^0) . We will consistently use the notation $\dot{e}_i = \bar{e}_i - e_i$ to denote the boundary of the edge e_i . It follows from Proposition 2.4 and the definition of a graph that

$$H_q(\bar{e}_i, \dot{e}_i) = \begin{cases} \mathbf{Z} & \text{for } q = 1 \\ 0 & \text{for } q \neq 1. \end{cases} \tag{8.3.1}$$

Theorem 3.2. *Let (X, X^0) be a finite, regular graph with edges e_1, e_2, \dots, e_k . Then the inclusion map $(\bar{e}_i, \dot{e}_i) \rightarrow (X, X^0)$ induces a monomorphism $H_q(\bar{e}_i, \dot{e}_i) \rightarrow H_q(X, X^0)$ for $i = 1, 2, \dots, k$ and $H_q(X, X^0)$ is the direct sum of the image subgroups. It follows that $H_1(X, X^0)$ is a free abelian group of rank k , and $H_q(X, X^0) = 0$ for $q \neq 1$.*

(Note: The rank of a free abelian group is the number of elements in a basis; it is proved in books on linear algebra that it is an invariant of the group).

PROOF. The third sentence of the theorem is a consequence of the two preceding sentences, in view of Equation (8.3.1). Therefore, we will concentrate our attention on the first two sentences of the theorem.

According to the definition of a graph, the set \bar{e}_i is homeomorphic to the unit interval $I = [0, 1]$; choose a definite homeomorphism of \bar{e}_i with I for $i = 1, 2, \dots, k$ and let a_i denote the point which corresponds to $\frac{1}{2} \in I$; it is the midpoint of the edge e_i . Similarly, let d_i denote the subset of e_i which corresponds to the closed subinterval $[\frac{1}{4}, \frac{3}{4}]$, and $D = d_1 \cup d_2 \cup \dots \cup d_k$, $A = \{a_1, a_2, \dots, a_k\}$. Our proof of the theorem is based on the consideration of the following diagram:

$$\begin{array}{ccccc} H_q(D, D - A) & \xrightarrow{1} & H_q(X, X - A) & \xleftarrow{2} & H_q(X, X^0) \\ \uparrow 5 & & \uparrow & & \uparrow 6 \\ H_q(d_i, d_i - \{a_i\}) & \xrightarrow{3} & H_q(\bar{e}_i, \bar{e}_i - \{a_i\}) & \xleftarrow{4} & H_q(\bar{e}_i, \dot{e}_i) \end{array}$$

All homomorphisms in this diagram are induced by inclusion maps of the corresponding pairs. It follows that each square of this diagram is commutative. We assert that *all four horizontal arrows in this diagram denote isomorphisms*. For arrow 4, this follows from the fact that \dot{e}_i is a deformation retract of $\bar{e}_i - \{a_i\}$, together with the five-lemma (Lemma VII.7.1). Exactly the same kind of argument shows that arrow 2 is an isomorphism. It follows from the excision property that arrows 1 and 3 are isomorphisms.

The theorem now follows from the fact that the space D is disconnected and its components are d_1, d_2, \dots, d_k , and $d_i - \{a_i\} = d_i \cap (D - A)$ (cf. Exercise VII.5.2). Q.E.D.

We will now consider the exact homology sequence of the pair (X, X^0) . The structure of the relative homology groups $H_q(X, X^0)$ is described by the theorem just proved. Since X^0 is a finite space with the discrete topology, $H_q(X^0) = 0$ for $q \neq 0$, and $H_0(X^0)$ is a free abelian group whose rank is equal to the number of vertices. From this it follows easily that $H_q(X) = 0$ for $q > 1$,

and the only nontrivial portion of the homology sequence of the pair (X, X^0) is the following:

$$0 \rightarrow H_1(X) \xrightarrow{j_*} H_1(X, X^0) \xrightarrow{\partial_*} H_0(X^0) \xrightarrow{i_*} H_0(X) \rightarrow 0. \quad (8.3.2)$$

We already know that $H_0(X)$ is a free abelian group whose rank is equal to the number of arc components of the topological space X . For a finite, regular graph, it is readily proved that the components and arc-components are the same.

Thus, we know the structure of all the groups in the homology sequence of the pair (X, X^0) , with the exception of $H_1(X)$. To determine the structure of this one remaining group, we need the following two results from linear algebra:

- (A) *Any subgroup of a free abelian group is also free abelian.*
- (B) *Let $f : A \rightarrow F$ be an epimorphism of an abelian group A onto the free abelian group F . Then the kernel of f is a direct summand of A ; the other summand is isomorphic to F .*

The proofs of these propositions may be found in textbooks on linear algebra. The proof of (B) is especially simple.

Definition 3.3. The *Euler characteristic* of a graph is the number of vertices minus the number of edges.

We can now state the main theorem about the homology groups of a graph:

Theorem 3.4. *Let (X, X^0) be a finite, regular graph. Then $H_q(X) = 0$ for $q > 1$, $H_1(X)$ is a free abelian group, and*

$$\text{rank}(H_0(X)) - \text{rank}(H_1(X)) = \text{Euler characteristic.}$$

We leave it to the reader to prove this theorem, using the homology sequence of the pair (X, X^0) and the two results from linear algebra stated above.

This theorem gives a simple method for determining the structure for $H_1(X)$. For we can determine the rank of $H_0(X)$ by counting the number of components, and we can determine the Euler characteristic by counting the number of vertices and edges. For certain purposes it is necessary to go more deeply into the structure of $H_1(X)$, and actually give some sort of concrete representation of the elements of this group. This we will now proceed to do.

The exact sequence (8.3.2) shows that $H_1(X)$ and $H_0(X)$ are the kernel and cokernel respectively of the homomorphism $\partial_* : H_1(X, X^0) \rightarrow H_0(X^0)$. Our procedure will be to choose convenient bases for the free abelian groups $H_1(X, X^0)$ and $H_0(X^0)$, and then express ∂_* in terms of these bases. The edges of the graph X will be denoted by e_1, \dots, e_k and the vertices by v_1, \dots, v_m .

It is easy to choose a natural basis for the group $H_0(X^0)$. Since X^0 is a discrete space, $H_0(X^0)$ is naturally isomorphic to the direct sum of the groups

$H_0(v_i)$ for $i = 1, 2, \dots, m$. The augmentation homomorphism $\varepsilon : H_0(v_i) \rightarrow \mathbf{Z}$ is an isomorphism; therefore it is natural to choose as a generator of $H_0(v_i)$ the element a_i such that $\varepsilon(a_i) = 1$. Then $\{a_1, \dots, a_m\}$ is a basis for $H_0(X^0)$. To avoid proliferation of notation, it is convenient to use the same symbol v_i for the basis element $a_i \in H_0(v_i)$. This abuse of notation will hardly ever lead to confusion, and it is sanctioned by many decades of use. Thus, we will denote our basis of $H_0(X^0)$ by $\{v_1, \dots, v_m\}$.

Choosing a basis for $H_1(X, X^0)$ is only slightly more complicated.

According to Theorem 3.2, $H_1(X, X^0)$ decomposes into the direct sum of infinite cyclic subgroups, which correspond to the edges e_1, \dots, e_k . Thus, to choose a basis for $H_1(X, X^0)$ it suffices to choose a generator for the infinite cyclic group $H_1(\bar{e}_i, \dot{e}_i)$ for $i = 1, 2, \dots, k$. It turns out that such a choice is purely arbitrary; there is no natural or preferred choice of a generator. In order to understand the meaning of such a choice, consider the following commutative diagram (cf. Exercise VII.5.5):

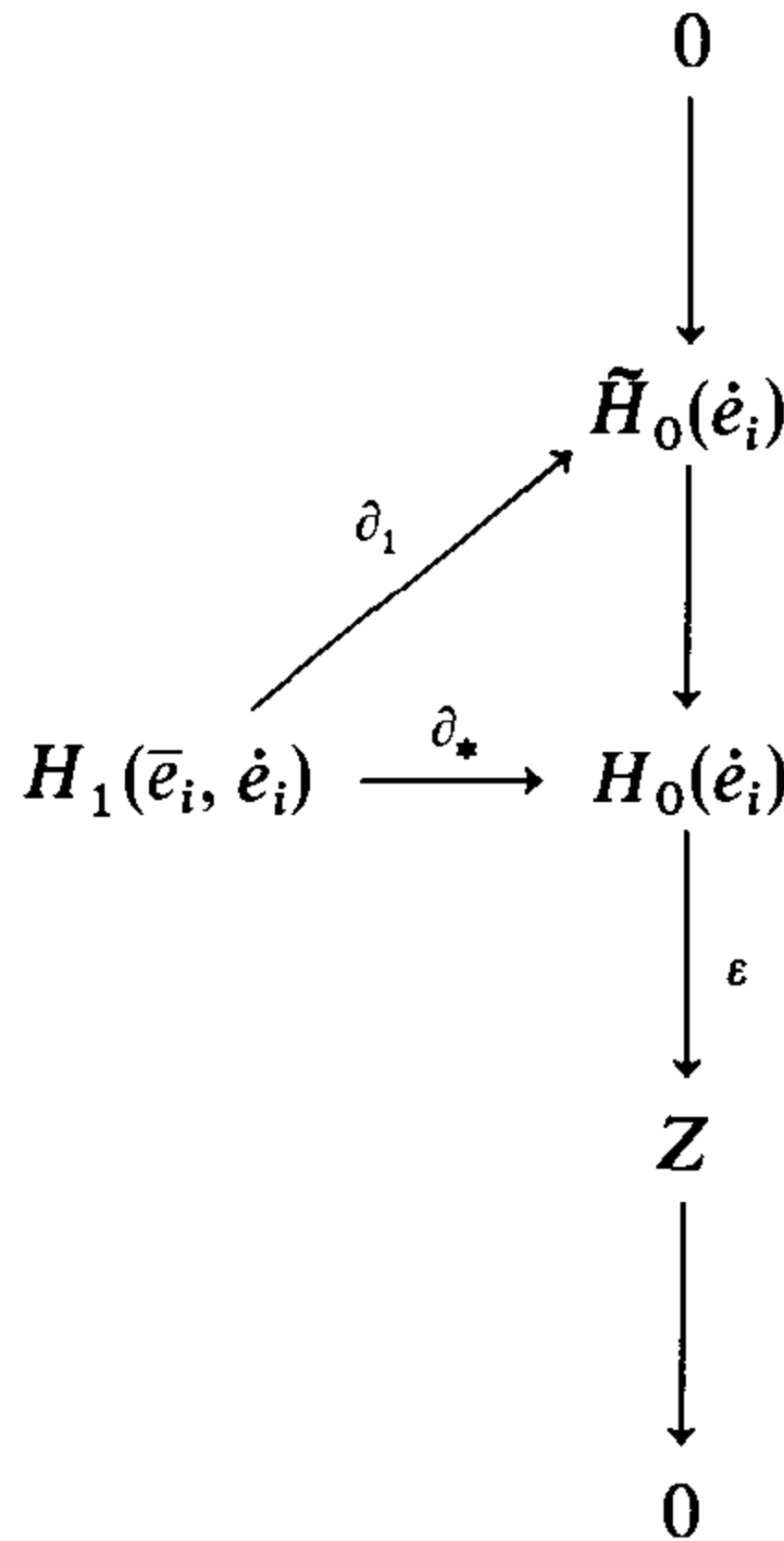

The homomorphism ∂_1 is an isomorphism; thus choosing a generator for $H_1(\bar{e}_i, \dot{e}_i)$ is equivalent to choosing a generator for $\tilde{H}_0(\dot{e}_i)$. The set \dot{e}_i consists of two vertices; let us denote them by v_α and v_β . Using the convention introduced in the preceding paragraph, we may use the same symbols, v_α and v_β , to denote a basis for $H_0(\dot{e}_i)$. With this convention, the two possible choices of a generator for the infinite cyclic subgroup $\tilde{H}_0(\dot{e}_i)$ are $v_\alpha - v_\beta$ and $v_\beta - v_\alpha$. Thus, we see that a choice of basis for $H_1(\bar{e}_i, \dot{e}_i)$ corresponds to an ordering of the vertices of the edge e_i . For this reason, we will say that we *orient* the edge e_i when we make such a choice. To make things precise, we lay down the following rule: *Orient the edge e_i by choosing an ordering of its two vertices. If $v_\beta > v_\alpha$, then this ordering of vertices corresponds to the generator $\partial_1^{-1}(v_\beta - v_\alpha)$ of the group $H_1(\bar{e}_i, \dot{e}_i)$.*

We can now give the following recipe for the homomorphism $\partial_* : H_1(X, X^0) \rightarrow H_0(X^0)$:

- (a) A basis for $H_0(X^0)$ consists of the set of vertices.
- (b) Orient the edges by choosing an order for the vertices of each edge. On a diagram or drawing of the given graph, it is convenient to indicate the orientation by an arrow on each edge pointing from the first vertex to the second.
- (c) A basis for $H_1(X, X^0)$ consists of the set of oriented edges.
- (d) If e_i is any edge, with vertices v_α and v_β and orientation determined by the relation $v_\beta > v_\alpha$, then

$$\partial_*(e_i) = v_\beta - v_\alpha.$$

Examples

3.1. Figure 8.1 shows a graph with six vertices and nine edges which cannot be imbedded in the plane. (This graph comes up in the well-known problem of the three houses and the three utilities.) We have oriented all the edges by placing arrows on them which point upward. According to the preceding rules, the homomorphism ∂_* is given by the following formulas:

$$\begin{aligned} \partial_*(e_1) &= v_1 && -v_4 \\ \partial_*(e_2) &= v_2 && -v_5 \\ \partial_*(e_3) &= v_3 && -v_6 \\ \partial_*(e_4) &= v_2 && -v_4 \\ \partial_*(e_5) &= v_3 && -v_5 \\ \partial_*(e_6) &= v_1 && -v_5 \\ \partial_*(e_7) &= v_2 && -v_6 \\ \partial_*(e_8) &= v_3 && -v_4 \\ \partial_*(e_9) &= v_1 && -v_6. \end{aligned}$$

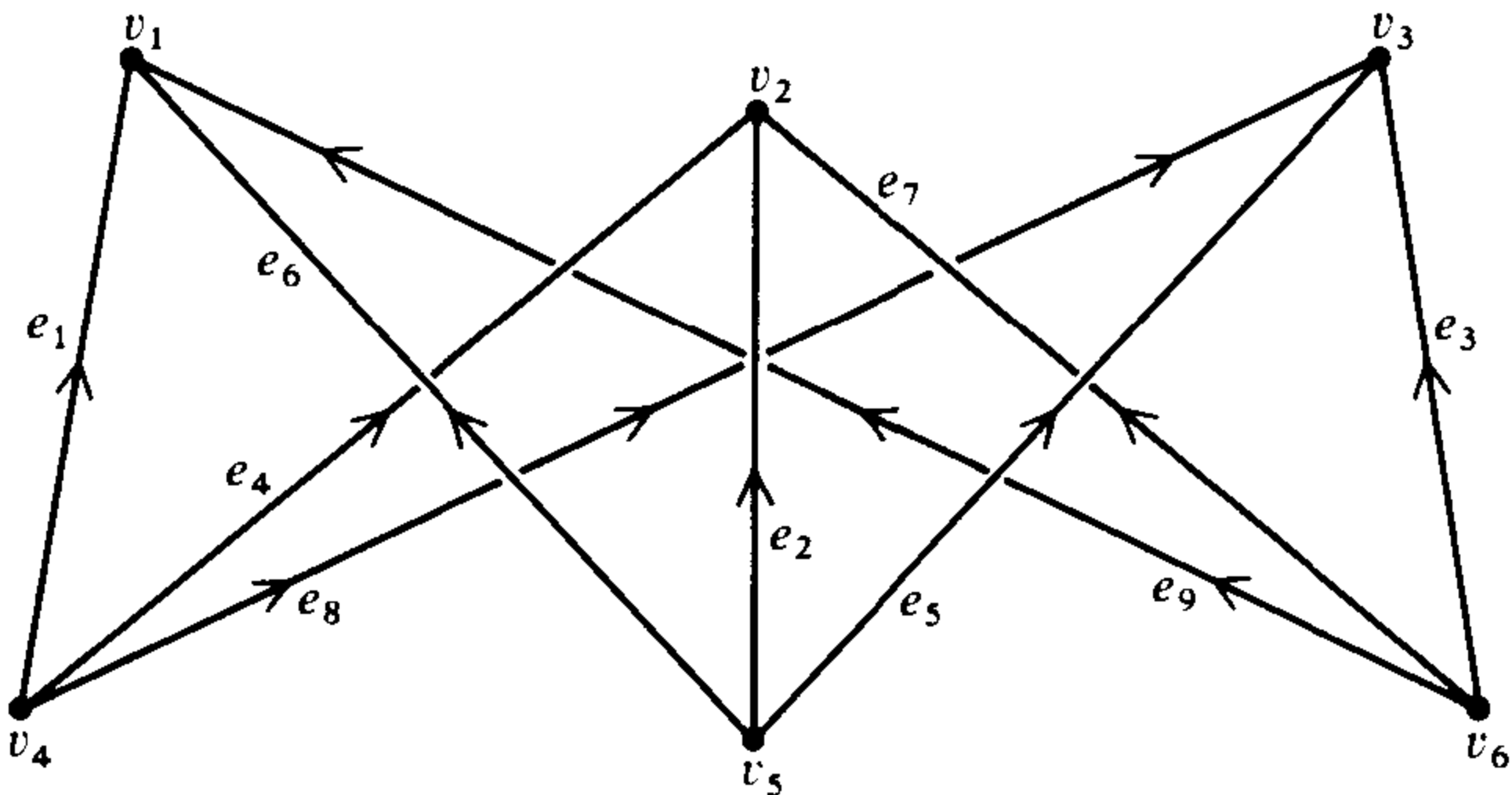

FIGURE 8.1

In other words, ∂_* is represented by the following matrix:

$$\begin{bmatrix} 1 & 0 & 0 & -1 & 0 & 0 \\ 0 & 1 & 0 & 0 & -1 & 0 \\ 0 & 0 & 1 & 0 & 0 & -1 \\ 0 & 1 & 0 & -1 & 0 & 0 \\ 0 & 0 & 1 & 0 & -1 & 0 \\ 1 & 0 & 0 & 0 & -1 & 0 \\ 0 & 1 & 0 & 0 & -0 & -1 \\ 0 & 0 & 1 & -1 & 0 & 0 \\ 1 & 0 & 0 & 0 & 0 & -1 \end{bmatrix}$$

There remains the problem of determining the kernel and cokernel of ∂_* . In books on linear algebra there is an algorithm described for introducing new bases in the domain and range of such a homomorphism so that the corresponding matrix is a diagonal matrix. Then generators of the kernel and cokernel can be read off with ease. Unfortunately, this algorithm is rather lengthy and tedious. As a practical alternative, one can proceed as follows.

The Euler characteristic of this graph is $6 - 9 = -3$. Since it is connected, $H_0(X)$ has rank 1. Hence $H_1(X)$ has rank 4, by Theorem 3.4. Therefore, we should be able to find four linearly independent elements in the kernel of ∂_* , and then hope to prove that they form a basis for the kernel of ∂_* . Consider the following four elements of $H_1(X, X^0)$:

$$z_1 = e_1 - e_6 + e_2 - e_4,$$

$$z_2 = e_2 - e_4 + e_8 - e_5,$$

$$z_3 = e_3 - e_5 + e_6 - e_9,$$

and

$$z_4 = e_7 - e_2 + e_5 - e_3.$$

These four elements (which we may as well call *cycles*) were determined by inspection of the above diagram. They correspond in an obvious way to certain oriented closed paths in the diagram. It is readily verified that all four of these cycles actually belong to the kernel of ∂_* , and that they are linearly independent. Finally, it is a nice exercise in linear algebra to check that the set $\{e_1, e_2, e_3, e_4, e_5, z_1, z_2, z_3, z_4\}$ is also a basis for $H_1(X, X^0)$. These facts suffice to prove that $\{z_1, z_2, z_3, z_4\}$ is actually a basis for the kernel of ∂_* , or what is equivalent, for the homology group $H_1(X)$. We leave it to the reader to carry through the details of the proof. The reader is strongly urged to make diagrams of several graphs and determine a set of linearly independent cycles which constitute a basis for the 1-dimensional homology group of each graph. It is only by such exercises that one can gain an adequate understanding and intuitive feeling for homology theory. The idea that a 1-dimensional homology class is represented by a linear combination of cycles is very important.

Next we will discuss the problem of determining the homomorphism induced on the 1-dimensional homology groups by a continuous map from one graph to another. This problem is probably just as important as the problem of determining the structure of the 1-dimensional homology groups. Let (X, X^0) and (Y, Y^0) be finite regular graphs and $f: X \rightarrow Y$ a continuous map. In order to have an effective procedure for determining the induced homomorphism $f_*: H_1(X) \rightarrow H_1(Y)$, it is necessary to impose some conditions of f . The following will be convenient for our purposes:

- (A) $f(X^0) \subset Y^0$, i.e., f maps vertices into vertices.
 (B) Given any edge e_i of X , either f maps \bar{e}_i homeomorphically onto some closed edge \bar{e}'_j of Y , or f maps \bar{e}_i onto a vertex of Y .

Of course, most continuous maps f do not satisfy these conditions. However, it can be shown that one can deform any map f homotopically into one which *does* satisfy them, provided one subdivides (X, X^0) first. In view of the invariance of f_* under homotopies, this is allowable for our purposes.

Since $f(X^0) \subset Y^0$, we may consider f as a map of pairs: $(X, X^0) \rightarrow (Y, Y^0)$. Hence we obtain the following commutative diagram involving the exact homology sequences of the pairs (X, X^0) and (Y, Y^0) :

$$\begin{array}{ccccccccccc}
 0 & \longrightarrow & H_1(X) & \xrightarrow{j_*} & H_1(X, X^0) & \xrightarrow{\partial_*} & H_0(X^0) & \xrightarrow{i_*} & H_0(X) & \longrightarrow & 0 \\
 & & \downarrow f_* & & \downarrow f_1 & & \downarrow f_0 & & \downarrow f_* & & \\
 0 & \longrightarrow & H_1(Y) & \xrightarrow{j_*} & H_1(Y, Y^0) & \xrightarrow{\partial_*} & H_0(Y^0) & \xrightarrow{i_*} & H_0(Y) & \longrightarrow & 0
 \end{array}$$

From this diagram, it is clear that the homomorphism $f_*: H_1(X) \rightarrow H_1(Y)$ is completely determined by the homomorphism labeled f_1 . To determine the homomorphism f_1 , it suffices to describe its effect on the basis we have chosen for $H_1(X, X^0)$, i.e., on the oriented edges. Suppose first that f maps \bar{e}_i homeomorphically onto the closed edge \bar{e}'_j of Y , as stated in condition (B) above. We assume that the edges e_i and e'_j have both been oriented by choosing an order of their vertices. Then two cases arise, according as the map f is orientation preserving, or orientation reversing (the meaning of these terms is obvious). We leave it to the reader to prove that

$$f_1(e_i) = \begin{cases} +e'_j & \text{if } f \text{ preserves orientation} \\ -e'_j & \text{if } f \text{ reverses orientation.} \end{cases}$$

Here f_1 denotes the homomorphism $H_1(X, X^0) \rightarrow H_1(Y, Y^0)$ induced by f , whereas $e_i \in H_1(X, X^0)$ and $e'_j \in H_1(Y, Y^0)$ denote the basis elements represented by the corresponding oriented edges. Suppose next that f maps the edge e_i of X onto the vertex v'_j of Y . Then

$$f_1(e_i) = 0.$$

To prove this equation, consider the following commutative diagram:

$$\begin{array}{ccc}
 H_1(X, X^0) & \xrightarrow{f_1} & H_1(Y, Y^0) \\
 \uparrow & & \uparrow \\
 H_1(\bar{e}_i, \dot{e}_i) & \xrightarrow{f_*} & H_1(v'_j, v'_j)
 \end{array}$$

The vertical arrows denote homomorphisms induced by inclusion maps. Since $H_1(v'_j, v'_j) = 0$, the assertion follows.

3.2. By subdividing into short arcs, the circle S^1 may be considered as a graph in various different ways. Let us consider S^1 as the unit circle in the complex plane, \mathbf{C} :

$$S^1 = \{z \in \mathbf{C} \mid |z| = 1\}.$$

Let $f: S^1 \rightarrow S^1$ be the continuous map defined by $f(z) = z^3$. We wish to determine the induced homomorphism $f_*: H_1(S^1) \rightarrow H_1(S^1)$. In order to solve this problem, we need to subdivide S^1 into a regular graph in two different ways. The first subdivision is into six equal arcs by means of the vertices

$$v_j = \exp\left(j \frac{\pi\sqrt{-1}}{3}\right), \quad j = 0, 1, \dots, 5.$$

The corresponding (oriented) edges e_0, e_1, \dots, e_5 are shown in Figure 8.2. The second subdivision is into two semicircles by the vertices $u_0 = +1$ and $u_1 = -1$; the corresponding (oriented) edges, denoted by e'_0 and e'_1 are also shown in the diagram. Let $X^0 = \{v_0, v_1, \dots, v_5\}$ and $Y^0 = \{u_0, u_1\}$. Then we can consider f as a map of pairs, $(S^1, X^0) \rightarrow (S^1, Y^0)$, and conditions (A) and (B) are fulfilled, with $X = Y = S^1$. The induced homomorphism $f_1: H_1(S^1, X^0) \rightarrow H_1(S^1, Y^0)$ is described by

$$f_1(e_j) = \begin{cases} -e'_0 & \text{if } j = 0, 2, \text{ or } 4 \\ -e'_1 & \text{if } j = 1, 3, \text{ or } 5 \end{cases} \quad (8.3.3)$$

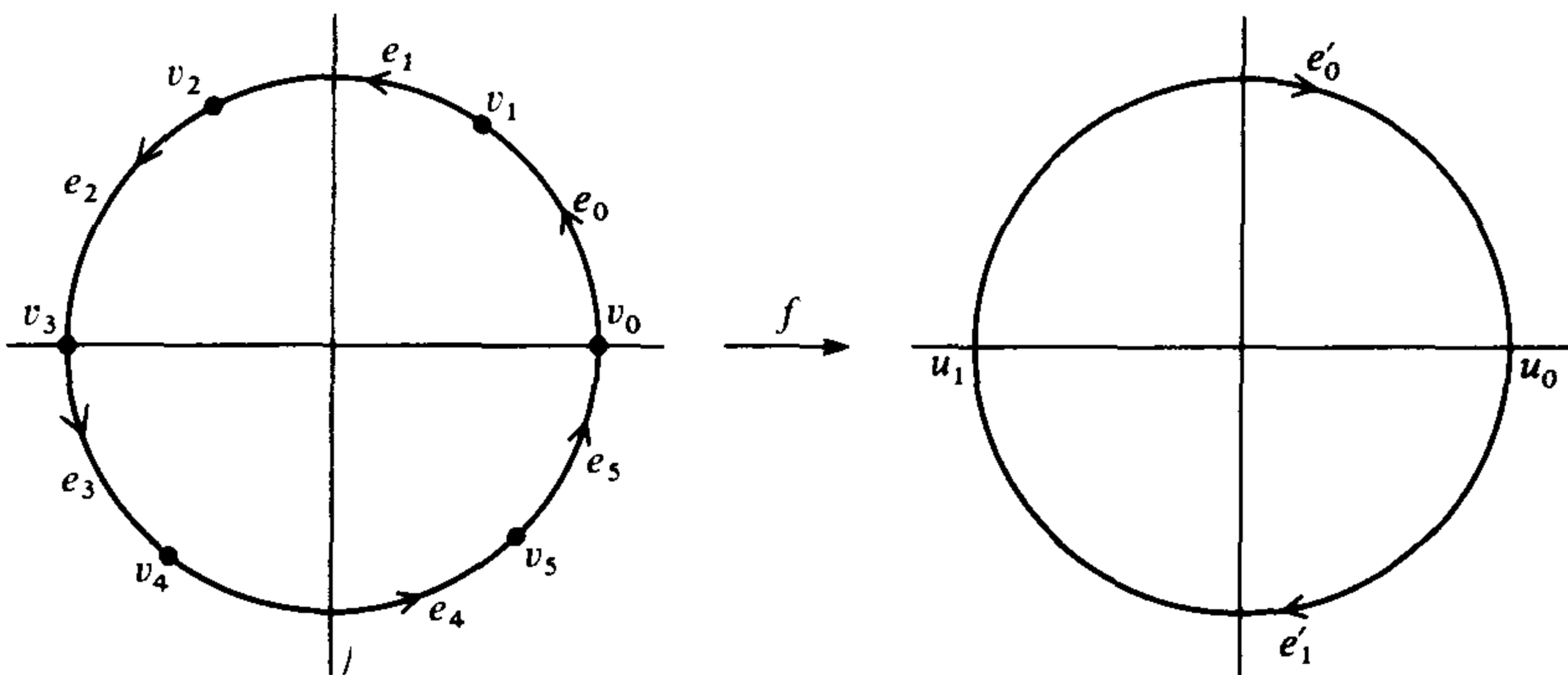

FIGURE 8.2

in view of our choice of orientations. The kernels of the homomorphisms

$$\partial_* : H_1(S^1, X^0) \rightarrow H_0(X^0),$$

$$\partial_* : H_1(S^1, Y^0) \rightarrow H_0(Y^0)$$

are both of rank 1, and they are generated by the cycles

$$x = \sum_{j=0}^5 e_j \quad \text{and} \quad y = e'_0 + e'_1, \quad (8.3.4)$$

respectively. We can consider each of these cycles as a representative of a generator of the infinite cyclic group $H_1(S^1)$; in view of the way the orientations of the edges were chosen, it seems likely that the generators so represented are the negatives of each other. It follows readily from Equations (8.3.3) and (8.3.4) that

$$f_1(x) = -3y;$$

thus, the map f has degree ± 3 . Actually, its degree is $+3$.

3.3. The preceding example raises the following question: suppose we subdivide a given space X into a finite regular graph in two different ways. Using each of these subdivisions, we can determine cycles which represent elements of the homology group $H_1(X)$. How can we compare representative cycles from the two different subdivisions? The following example shows how this problem can be solved. Consider two different subdivisions of the unit circle S^1 in the complex plane; for example, consider the two subdivisions considered in the previous example with vertex sets

$$X^0 = \{v_0, \dots, v_5\} \quad \text{and} \quad Y^0 = \{u_0, u_1\},$$

respectively. We will define a continuous map $g : S^1 \rightarrow S^1$ such that g is homotopic to the identity map, and so that g is a map of pairs $(S^1, X^0) \rightarrow (S^1, Y^0)$ such that conditions (A) and (B) hold. The easiest way to define g is to define it separately on each closed cell \bar{e}_j , taking care that the various mappings so defined agree on the end points of the cells. We list the definitions as follows:

- (a) g shall map \bar{e}_0 homeomorphically onto \bar{e}'_0 with $g(v_0) = u_0$ and $g(v_1) = u_1$.
- (b) $g(\bar{e}_1) = g(\bar{e}_2) = u_1$.
- (c) g maps \bar{e}_3 homeomorphically onto e'_1 with $g(v_3) = u_1$ and $g(v_4) = u_0$.
- (d) $g(\bar{e}_4) = g(\bar{e}_5) = u_0$.

We leave it to the reader to verify that g is actually homotopic to the identity map of S^1 onto itself. The induced homomorphism $g_1 : H_1(S^1, X^0) \rightarrow H_1(S^1, Y^0)$ is described by the following equations, using the same orientations of edges as in the preceding example:

$$g_1(e_0) = -e'_0,$$

$$g_1(e_3) = -e'_1,$$

$$g_1(e_j) = 0 \quad \text{for } j = 1, 2, 4, \text{ or } 5.$$

From this it follows that

$$g_1(x) = -y,$$

where x and y are the cycles defined in the previous example. Since g is homotopic to the identity map, we know that the induced homomorphism $g_* : H_1(S^1) \rightarrow H_1(S^1)$ is the identity homomorphism. From this it follows that the cycles x and $-y$ represent the same homology class.

The point of this example is not so much to prove rigorously what is intuitively obvious, as it is to illustrate a general procedure for handling questions of this kind.

EXERCISES

- 3.1. Determine the degree of the mapping $f : S^1 \rightarrow S^1$ defined by $f(z) = z^k$ for any integer k .
- 3.2. Prove that for any integer k and any positive integer n there exists a continuous map $f : S^n \rightarrow S^n$ of degree k .
- 3.3. Identify S^2 with the Alexandroff 1-point compactification of the complex plane \mathbb{C} , obtained by adjoining a point to \mathbb{C} , called the *point at infinity*. Let $f(z)$ be a polynomial of positive degree with complex coefficients; we may consider f to be a continuous nonconstant map $f : \mathbb{C} \rightarrow \mathbb{C}$. Prove that we may extend f to a continuous map $\bar{f} : S^2 \rightarrow S^2$ by mapping the point at infinity onto itself.
- 3.4. Let $f(z) = z^k$, $k > 0$. Determine the degree of the extension $\bar{f} : S^2 \rightarrow S^2$ of f defined according to the procedure of the preceding exercise.
- 3.5. Let $f(x)$ be a polynomial of degree $k > 0$ with complex coefficients. Determine the degree of the extension $\bar{f} : S^2 \rightarrow S^2$ of f defined as above.
- 3.6. Let $f(z)$ be a polynomial of degree $k > 0$ with complex coefficients. Prove that the equation $f(z) = 0$ has at least one root in the field of complex numbers, \mathbb{C} (this is the so-called *fundamental theorem of algebra*).
- 3.7. Let $X = \{(x, y, z) \in \mathbb{R}^3 \mid xyz = 0\}$ i.e., X is the union of the three coordinate planes. Prove that any homeomorphism of X onto itself must have the origin, $(0, 0, 0)$, as a fixed point. (SUGGESTION: Determine the local homology groups at various points.)
- 3.8. Use local homology groups to prove that any triangulation of a compact surface satisfies conditions (1) and (2) stated near the end of §I.6.

§4. Homology of Compact Surfaces

A compact surface is homeomorphic to one of the following: the 2-sphere, S^2 ; the torus, $S^1 \times S^1$; the real projective plane; a connected sum of tori; or, a connected sum of projective planes. For a description of these various surfaces, see Chapter I. The main fact that we will use is that every compact surface

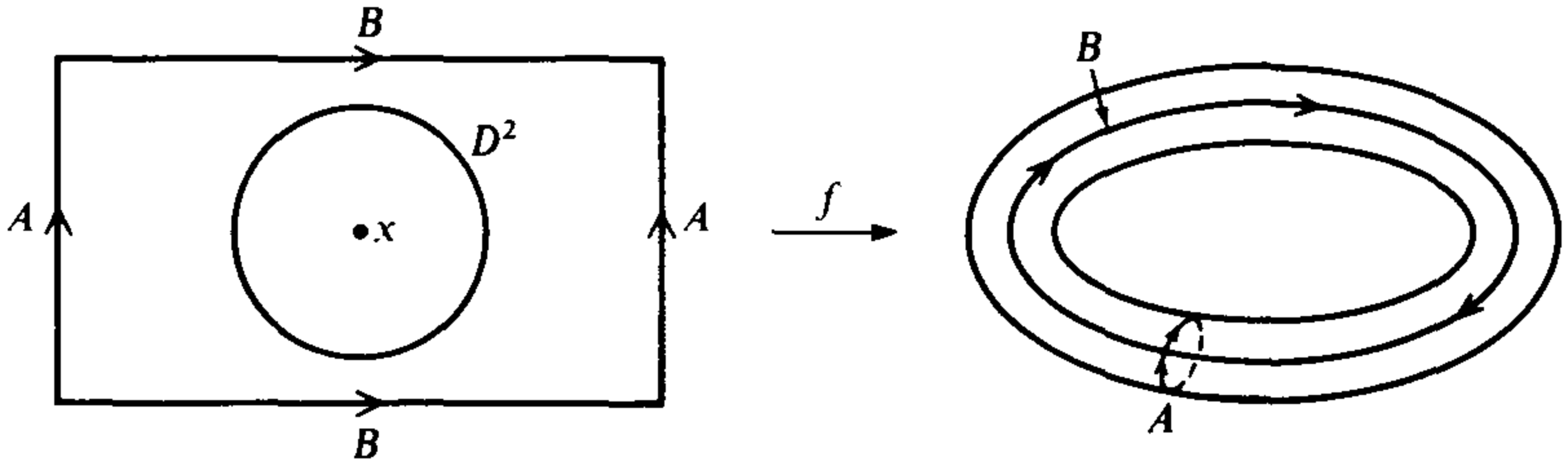

FIGURE 8.3

can be obtained from some polygonal disc by identifying the edges in pairs according to a certain scheme.

Examples

4.1 (the torus). We can think of a torus as obtained from a rectangle by identification of the opposite edges, as shown in Figure 8.3. Under the identification, each pair of edges becomes a circle, and the two circles, labeled A and B in the diagram, intersect in a single point. We will use the following notation:

- $E^2 =$ the rectangle,
- $X =$ the torus,
- $f: E^2 \rightarrow X,$ the identification map,
- $\dot{E}^2 =$ boundary of the rectangle,
- $X^1 = f(\dot{E}^2) = A \cup B.$

The homology groups of X^1 can be determined by the methods of the preceding section. If we knew the relative homology groups $H_q(X, X^1)$, then we could hope to determine the homology groups of X by studying the exact homology sequence of the pair (X, X^1) .

Proposition 4.1. *The identification map $f: (E^2, \dot{E}^2) \rightarrow (X, X^1)$ induces an isomorphism $f_*: H_q(E^2, \dot{E}^2) \rightarrow H_q(X, X^1)$ of relative homology groups for all q . Hence $H_q(X, X^1) = 0$ for $q \neq 2$, and $H_2(X, X^1)$ is infinite cyclic.*

PROOF. The last sentence is a consequence of the first sentence and Proposition 2.4. The pattern of proof of the first sentence of the proposition, using the excision property, deformation retracts, etc., is one that we have used before.

Let x denote the center point of the rectangle E^2 , and let D^2 denote a closed disc with center at the point x whose radius is small enough so that it is contained entirely in the interior of the rectangle E^2 . Consider the following diagram of relative homology groups:

$$\begin{array}{ccccc}
 H_q(E^2, \dot{E}^2) & \xrightarrow{1} & H_q(E^2, E^2 - \{x\}) & \xleftarrow{3} & H_q(D^2, D^2 - \{x\}) \\
 \downarrow f_* & & \downarrow & & \downarrow 5 \\
 H_q(X, X^1) & \xrightarrow{2} & H_q(X, X - \{fx\}) & \xleftarrow{4} & H_q(fD^2, fD^2 - \{fx\})
 \end{array}$$

In this diagram the horizontal arrows all denote homomorphisms induced by inclusion maps, and the vertical arrows denote homomorphisms induced by f . Each square in the diagram is commutative.

We assert that the four homomorphisms denoted by horizontal arrows are all isomorphisms. For arrows 3 and 4 this assertion follows from the excision property. For arrow 1, it follows from the fact that \dot{E}^2 is a deformation retract of $E^2 - \{x\}$; one must also use the five-lemma. By a similar argument, the assertion can be proved for arrow 2.

To complete the proof, observe that arrow 5 is an isomorphism because f maps D^2 homeomorphically onto $f(D^2)$. It now follows from the commutativity of the diagram that f_* is also an isomorphism. Q.E.D.

The subset X^1 of X can be subdivided so as to be a finite, regular graph; it is obviously connected, and its Euler characteristic is -1 . Therefore, $H_0(X^1) = \mathbf{Z}$, $H_1(X^1) = \mathbf{Z} \oplus \mathbf{Z}$, and $H_q(X^1) = 0$ for $q > 1$. If we put this information about the homology groups of (X, X^1) and X^1 into the exact homology sequence of the pair (X, X^1) , we see that $H_q(X) = 0$ for $q > 2$, and the only nontrivial part of this homology sequence is the following:

$$0 \rightarrow H_2(X) \xrightarrow{j_*} H_2(X, X^1) \xrightarrow{\partial_*} H_1(X^1) \xrightarrow{i_*} H_1(X) \rightarrow 0. \quad (8.4.1)$$

From this sequence, we see that $H_2(X)$ and $H_1(X)$ are the kernel and cokernel, respectively, of the homomorphism ∂_* . Thus, it is necessary to determine ∂_* . For this purpose consider the following commutative diagram:

$$\begin{array}{ccc} H_2(X, X^1) & \xrightarrow{\partial_*} & H_1(X^1) \\ \uparrow f_* & & \uparrow f_{1*} \\ H_2(E^2, \dot{E}^2) & \xrightarrow{\partial'_*} & H_1(\dot{E}^2) \end{array}$$

By the proposition just proved, f_* is an isomorphism. It follows from consideration of the homology sequence of the pair (E^2, \dot{E}^2) that ∂'_* is an isomorphism. The homomorphism f_{1*} is induced by the identification maps $f_1 : \dot{E}^2 \rightarrow X^1$; this is a map of finite, regular graphs of the type discussed in §3. Using the techniques of that section, it is a routine matter to calculate the f_{1*} is the zero homomorphism; we leave the details to the reader. From this it follows that ∂_* is also the zero homomorphism.

Going back to the exact sequence (8.4.1) we see that both j_* and i_* are isomorphisms. Thus, we have completely determined the structure of the homology groups of the torus, as follows:

$$H_0(X) = \mathbf{Z} \quad (X \text{ is connected}),$$

$$H_1(X) = \mathbf{Z} \oplus \mathbf{Z},$$

$$H_2(X) = \mathbf{Z},$$

and

$$H_q(X) = 0 \quad \text{for } q > 2.$$

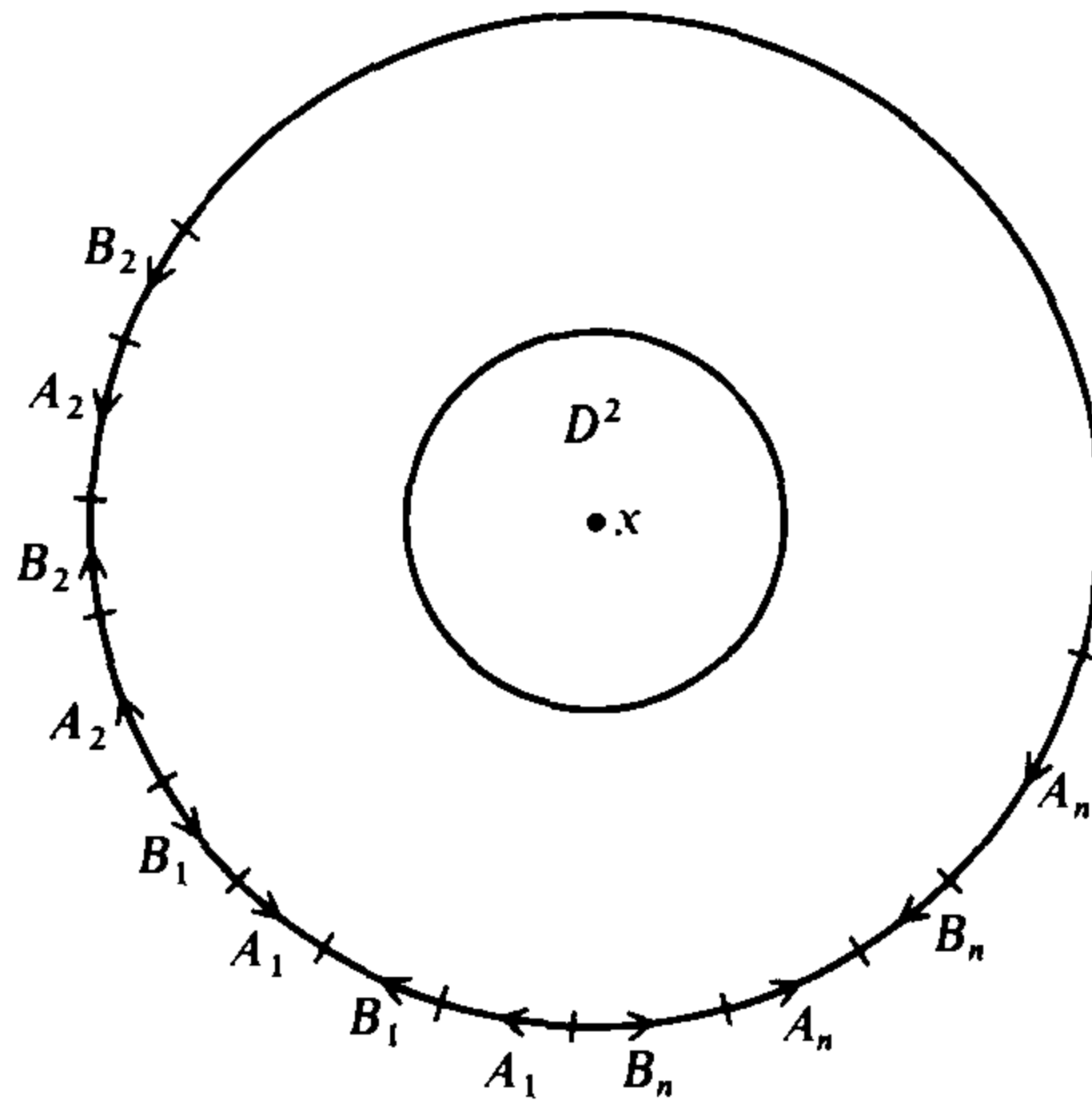

FIGURE 8.4

The fact that the inclusion map $i: X^1 \rightarrow X$ induces an isomorphism $i_*: H_1(X^1) \rightarrow H_1(X)$ is also significant. This means that elements of $H_1(X)$ can be represented by cycles on the graph X^1 . Note also that this statement is still true if the inclusion map $i: X^1 \rightarrow X$ is deformed homotopically into some other map.

4.2 [the connected sum of n tori, $n > 1$ (an orientable surface of genus n)]. This example is completely analogous to the torus. Such a surface can be obtained from a polygonal disc having $4n$ edges by identifying the edges in pairs according to the scheme shown in Figure 8.4. Under the identification, each pair of edges becomes a circle on the surface X , and these $2n$ circles, which may be denoted $A_1, A_2, \dots, A_n, B_1, B_2, \dots, B_n$ all intersect in a single point. The union of these circles may be denoted by the symbol X^1 , by analogy with the case of the torus. Let (E^2, \dot{E}^2) denote the pair consisting of the polygonal disc and its boundary circle. One can prove that the identification map $f: (E^2, \dot{E}^2) \rightarrow (X, X^1)$ induces isomorphisms $f_*: H_q(E^2, \dot{E}^2) \rightarrow H_q(X, X^1)$ for all q ; the proof of Proposition 4.1 applies without any essential change. Then one completes the determination of the homology groups of X by studying the homology sequence of the pair (X, X^1) . The final results are the following:

$H_0(X)$ and $H_2(X)$ are infinite cyclic,

$H_1(X)$ is free abelian of rank $2n$,

and

$$H_q(X) = 0 \quad \text{for } q > 2.$$

Exactly as in the case of the torus, the inclusion map $i: X^1 \rightarrow X$ induces an isomorphism $i_*: H_1(X^1) \rightarrow H_1(X)$.

4.3 (the projective plane). The projective plane may be obtained from a circular disc by identifying diametrically opposite points on the boundary. It is harder to visualize than the surfaces we have considered so far because it can not be imbedded homeomorphically in Euclidean 3-space. It is a non-orientable surface, and this results in a somewhat different structure for its homology groups, as we shall see.

As in the previous cases, denote the disc by E^2 , the projective plane by X , and let $f: (E^2, \dot{E}^2) \rightarrow (X, X^1)$ be the identification map. Here \dot{E}^2 denotes the boundary circle of E^2 , and $X^1 = f(\dot{E}^2)$ is also a circle. The induced map $f_1: \dot{E}^2 \rightarrow X^1$ is a 2-to-1 map, i.e., it has degree ± 2 . Exactly as before, we can prove that $f_*: H_q(E^2, \dot{E}^2) \rightarrow H_q(X, X^1)$ is an isomorphism for all q . The only nontrivial part of the homology sequence of the pair (X, X^1) is the following:

$$\begin{array}{ccccccccc}
 0 & \longrightarrow & H_2(X) & \xrightarrow{j_*} & H_2(X, X^1) & \xrightarrow{\partial_*} & H_1(X^1) & \xrightarrow{i_*} & H_1(X) & \longrightarrow & 0 \\
 & & & & \uparrow f_* & & \uparrow f_{1*} & & & & \\
 & & & & H_2(E^2, \dot{E}^2) & \xrightarrow{\partial'_*} & H_1(\dot{E}^2) & & & &
 \end{array}$$

Since f_* and ∂'_* are isomorphisms, and f_{1*} has degree ± 2 , we conclude that ∂_* also has degree ± 2 . It now follows from exactness of the homology sequence of (X, X^1) that

$$H_2(X) = 0$$

and

$$H_1(X) \text{ is cyclic of order 2.}$$

Of course $H_0(X) = \mathbf{Z}$ and $H_q(X) = 0$ for $q > 2$ exactly as before.

This is our first example of a space whose homology groups have an element of finite order; in fact it is probably the simplest example of such a space. It can be proved that if X is any reasonable subset of Euclidean 3-space, its homology groups have no elements of finite order.

4.4 (the Klein bottle, K). We have two different ways of obtaining a Klein bottle by identifying edges of a square: That indicated on the left in Figure 8.5, in which opposite edges are to be identified, or that indicated on the right in Figure 8.5, in which adjacent edges are to be identified. It is interesting to use both representations to compute the homology groups of K , and then compare the results. The details are left to the reader. In either case, it is readily seen that $H_2(K) = 0$. What is the structure of $H_1(K)$? How can one prove algebraically that both methods lead to the same result?

4.5 (and arbitrary nonorientable compact surface). An arbitrary nonorient-

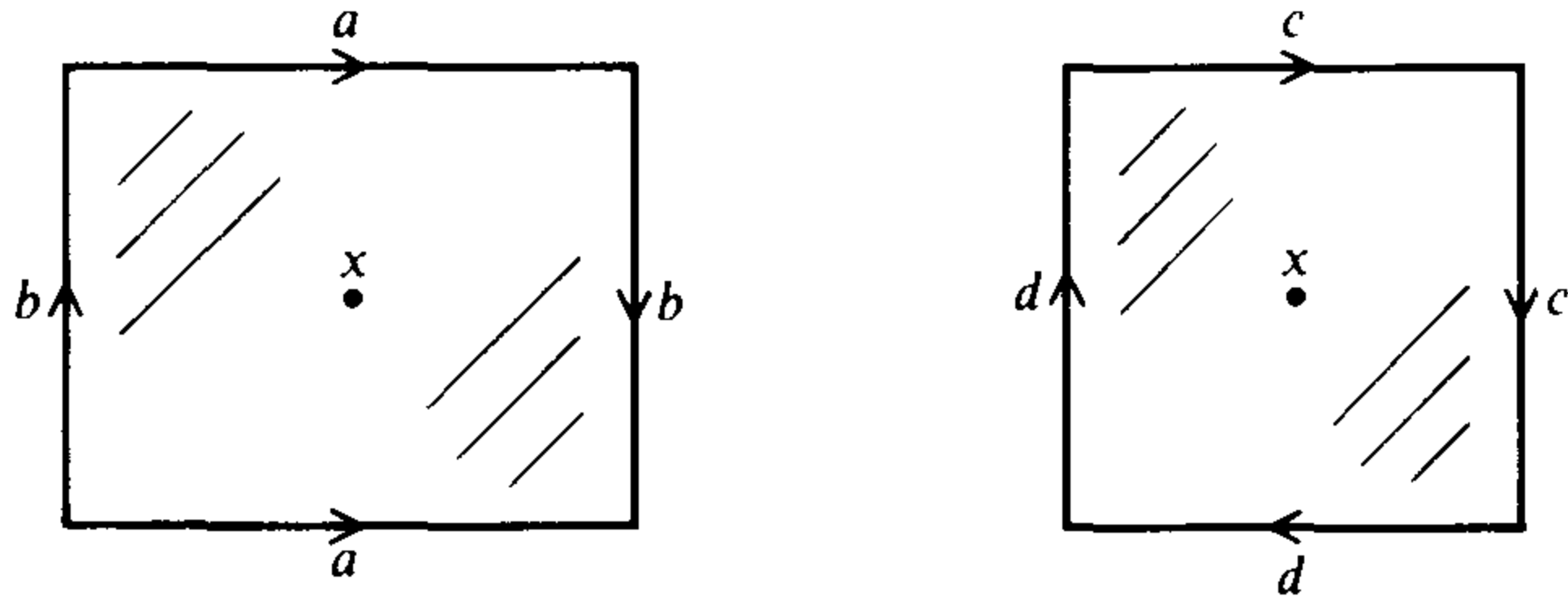

FIGURE 8.5

able surface X is the connected sum of n projective planes, $n \geq 1$. If n is odd, it can be considered as the connected sum of a projective plane and an orientable surface, whereas if n is even, it can be considered as the connected sum of a Klein bottle and an orientable surface. The integer n is sometimes called the *genus* of the nonorientable surface. Whether n is odd or even, we obtain two distinct ways of representing X as the quotient space of disc; for details, Chapter IV, Example 5.4. The reader should use at least one of these ways (and preferably both) to determine the homology groups of X . The final result is that $H_2(X) = 0$, and $H_1(X)$ is the direct sum of a free abelian group of rank $n - 1$ and a cyclic group of order 2.

Note that for the orientable surfaces, $H_2(X)$ is infinite cyclic and $H_1(X)$ is a free abelian group, whereas for nonorientable surfaces $H_2(X) = 0$ and $H_1(X)$ has a subgroup which is cyclic of order 2. Later we will see that analogous results hold for compact, connected n -dimensional manifolds for any positive integer n .

EXERCISES

- 4.1. Compute the homology groups of a space obtained by identifying the three edges of a triangle to a single edge as shown in Figure 8.6. (NOTE: This space is not a manifold.)
- 4.2. Given any integer $n > 1$, show how to construct a space X such that $H_1(X)$ is cyclic of order n .

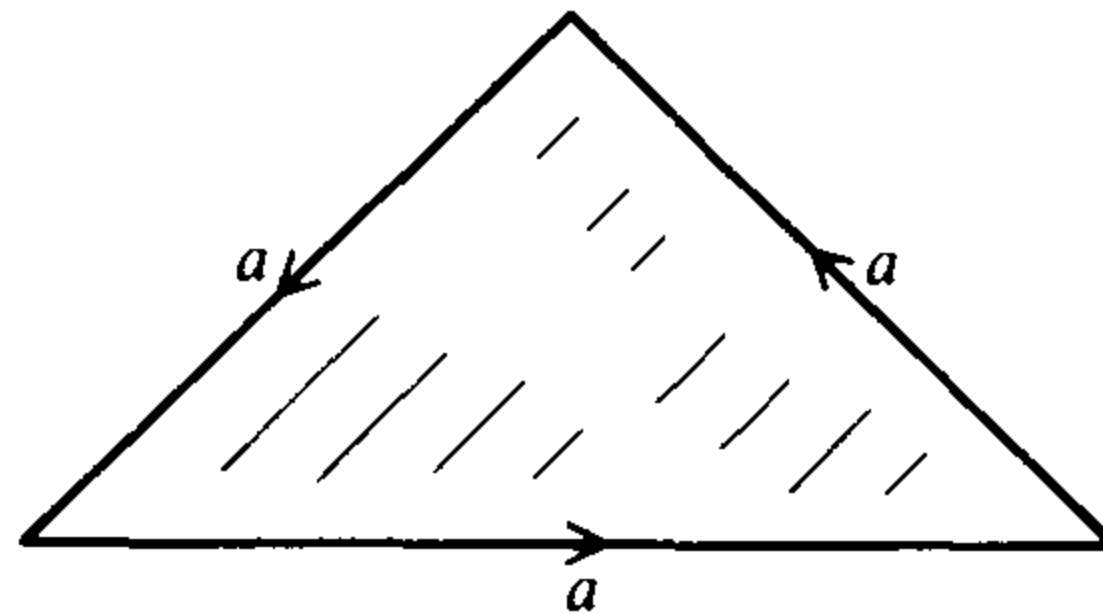

FIGURE 8.6

§5. The Mayer–Vietoris Exact Sequence

In this section we will be concerned with the following question: Suppose the space X is the union of two subspaces,

$$X = A \cup B.$$

What relations hold between the homology groups of the three subspaces A , B , $A \cap B$ and the homology groups of the whole space? If we make certain rather mild assumptions on the subspaces involved, we can give a rather nice answer to this question in the form of an exact sequence, called the Mayer–Vietoris sequence. This exact sequence plays the same role in homology theory that the Seifert–Van Kampen theorem plays in the study of the fundamental group (see Chapter IV).

In order to describe this exact sequence, let

$$i_* : H_n(A \cap B) \rightarrow H_n(A),$$

$$j_* : H_n(A \cap B) \rightarrow H_n(B),$$

$$k_* : H_n(A) \rightarrow H_n(X),$$

and

$$l_* : H_n(B) \rightarrow H_n(X)$$

denote homomorphisms induced by inclusion maps. Using these homomorphisms, we define homomorphisms

$$\varphi : H_n(A \cap B) \rightarrow H_n(A) \oplus H_n(B),$$

$$\psi : H_n(A) \oplus H_n(B) \rightarrow H_n(X)$$

by the formulas

$$\varphi(x) = (i_*(x), j_*(x)), \quad x \in H_n(A \cap B),$$

$$\psi(u, v) = k_*(u) - l_*(v), \quad u \in H_n(A), v \in H_n(B).$$

Theorem 5.1. *Let A and B be subsets of the topological space X such that $X = (\text{interior } A) \cup (\text{interior } B)$. Then it is possible to define natural homomorphisms*

$$\Delta : H_n(X) \rightarrow H_{n-1}(A \cap B)$$

for all values of n such that the following sequence is exact:

$$\cdots \xrightarrow{\Delta} H_n(A \cap B) \xrightarrow{\varphi} H_n(A) \oplus H_n(B) \xrightarrow{\psi} H_n(X) \xrightarrow{\Delta} H_{n-1}(A \cap B) \xrightarrow{\varphi} \cdots$$

If $A \cap B \neq \emptyset$, the sequence remains exact if we substitute reduced homology groups for ordinary homology groups in dimension 0.

This sequence is called the Mayer–Vietoris sequence. The statement that the homomorphism Δ is natural has the following precise technical meaning: Assume that the subspaces A' and B' of X' are such that

$$X' = (\text{interior } A') \cup (\text{interior } B')$$

and that $f : X \rightarrow X'$ is a continuous map such that $f(A) \subset A'$ and $f(B) \subset B'$. Then the following diagram is commutative for all n :

$$\begin{array}{ccc} H_n(X) & \xrightarrow{\Delta} & H_{n-1}(A \cap B) \\ \downarrow f_* & & \downarrow f_* \\ H_n(X') & \xrightarrow{\Delta} & H_{n-1}(A' \cap B') \end{array}$$

PROOF OF THEOREM 5.1. Let $\mathcal{U} = \{A, B\}$; in view of the hypotheses assumed on A and B we can apply Theorem VII.6.4 to conclude that the inclusion homomorphisms $\sigma : C_n(X, \mathcal{U}) \rightarrow C_n(X)$ induces isomorphisms $\sigma_* : H_n(X, \mathcal{U}) \rightarrow H_n(X)$ for all n . Note that

$$C_n(X, \mathcal{U}) = C_n(A) + C_n(B),$$

where the group on the right is the least subgroup of $C_n(X)$ containing $C_n(A)$ and $C_n(B)$ (it is *not* a direct sum). Therefore, the homomorphisms $k_{\#} : C_n(A) \rightarrow C_n(X)$ and $l_{\#} : C_n(B) \rightarrow C_n(X)$ have the property that their images are contained in the subgroup $C_n(X, \mathcal{U})$ in each case. Hence we have commutative diagrams as follows:

$$\begin{array}{ccc} & C_n(X, \mathcal{U}) & \\ k'_* \nearrow & \downarrow \sigma & \nwarrow l'_* \\ C_n(A) & & C_n(B) \\ k_* \searrow & & \searrow l_* \\ & C_n(X) & \end{array}$$

Our strategy will be to replace the group $H_n(X)$ by $H_n(X, \mathcal{U})$ in proving Theorem 5.1; when we do this, we must systematically replace k by k' and l by l' . We will assume this has been done, and from now on will drop the primes from the notation for these homomorphisms.

By analogy with the definition of the homomorphisms φ and ψ above, we define homomorphisms

$$\Phi : C_n(A \cap B) \rightarrow C_n(A) \oplus C_n(B),$$

$$\Psi : C_n(A) \oplus C_n(B) \rightarrow C_n(X, \mathcal{U})$$

by the following formulas:

$$\Phi(x) = (i_{\#} x, j_{\#} x),$$

$$\Psi(u, v) = k_{\#}(u) - l_{\#}(v).$$

Now consider the following diagram of chain groups and homomorphisms:

$$\begin{array}{ccccccc}
 & \vdots & & \vdots & & \vdots & \\
 & \downarrow & & \downarrow & & \downarrow & \\
 0 & \longrightarrow & C_{n+1}(A \cap B) & \xrightarrow{\Phi} & C_{n+1}(A) \oplus C_{n+1}(B) & \xrightarrow{\Psi} & C_{n+1}(X, \mathcal{U}) \longrightarrow 0 \\
 & & \downarrow & & \downarrow & & \downarrow \\
 0 & \longrightarrow & C_n(A \cap B) & \xrightarrow{\Phi} & C_n(A) \oplus C_n(B) & \xrightarrow{\Psi} & C_n(X, \mathcal{U}) \longrightarrow 0 \\
 & & \downarrow & & \downarrow & & \downarrow \\
 0 & \longrightarrow & C_{n-1}(A \cap B) & \xrightarrow{\Phi} & C_{n-1}(A) \oplus C_{n-1}(B) & \xrightarrow{\Psi} & C_{n-1}(X, \mathcal{U}) \longrightarrow 0 \\
 & & \downarrow & & \downarrow & & \downarrow \\
 & & \vdots & & \vdots & & \vdots
 \end{array}$$

The vertical arrows denote the appropriate boundary operator in each case. In the case of the vertical arrows in the middle column, this means the direct sum of the boundary operators for A and B . The two most important facts about this diagram are the following:

- (1) Each square of this diagram is commutative. This is practically obvious, in view of the way the homomorphisms Φ and Ψ were defined.
- (2) Each horizontal line in this diagram is exact. The verification of this fact is left to the reader; it should not present any real difficulty.

The reader should now compare this diagram with Diagram (7.5.1) which was used to set up the exact homology sequence of a pair. The essential properties of the two diagrams are the same. By the same process that was used in §VII.5 to define the boundary operator of a pair, one can now define the homomorphisms

$$\Delta : H_n(X, \mathcal{U}) \rightarrow H_{n-1}(A \cap B)$$

for all values of n . Moreover, the methods used to prove the exactness of the homology sequence of a pair apply without change to give the exactness of the following sequence of groups and homomorphisms:

$$\cdots \xrightarrow{\Delta} H_n(A \cap B) \xrightarrow{\varphi} H_n(A) \oplus H_n(B) \xrightarrow{\psi} H_n(X, \mathcal{U}) \xrightarrow{\Delta} \cdots$$

All this remains is to substitute $H_n(X)$ for $H_n(X, \mathcal{U})$, and we have proved the exactness of the Mayer–Vietoris sequence.

We leave it to the reader to verify that the homomorphism Δ is natural and to investigate what happens when one uses reduced homology groups in dimension 0 (provided $A \cap B \neq \emptyset$). Q.E.D.

Examples

5.1. We will show how the Mayer–Vietoris sequence can be used to make the inductive step in the proof of Theorem 2.1. As the inductive hypothesis, assume that $\tilde{H}_n(S^n) = \mathbf{Z}$, and $\tilde{H}_i(S^n) = 0$ for $i \neq n$. We wish to determine $\tilde{H}_i(S^{n+1})$. Let A be the complement of the point $(0, \dots, 0, -1)$ in S^{n+1} and let B be the complement of the point $(0, \dots, 0, +1)$ in S^{n+1} . Then A and B are open subsets of S^{n+1} , and $A \cup B = S^{n+1}$. Therefore, we can apply the Mayer–Vietoris sequence; in this case $A \cap B \neq \emptyset$, and it is convenient to use reduced homology groups in dimension 0. Consider the following portion of the sequence:

$$\tilde{H}_{i+1}(A) \oplus \tilde{H}_{i+1}(B) \rightarrow \tilde{H}_{i+1}(S^{n+1}) \xrightarrow{\Delta} \tilde{H}_i(A \cap B) \rightarrow \tilde{H}_i(A) \oplus \tilde{H}_i(B).$$

One proves by stereographic projection that A and B are both homeomorphic to \mathbf{R}^{n+1} , hence they are contractible. Therefore, $\tilde{H}_i(A) = \tilde{H}_i(B) = 0$ for all i . It follows by exactness that Δ is an isomorphism. Now $A \cap B$ is homeomorphic to \mathbf{R}^{n+1} minus a point, and therefore it contains S^n as a deformation retract. Hence by the inductive hypothesis $\tilde{H}_n(A \cap B) = \mathbf{Z}$, and $\tilde{H}_i(A \cap B) = 0$ for $i \neq n$. Since Δ is an isomorphism, it follows that $\tilde{H}_{n+1}(S^{n+1}) = \mathbf{Z}$, and $\tilde{H}_i(S^{n+1}) = 0$ for $i \neq n+1$, as was to be proved.

One final comment about the Mayer–Vietoris sequence: we could weaken the hypotheses of Theorem 5.1 to read $X = A \cup B$, provided we knew that the inclusion homomorphism $C_n(A) + C_n(B) \rightarrow C_n(X)$ induced isomorphisms on homology groups; this was the purpose of the assumption that the *interiors* of A and B cover X . We will come back to this point later.

EXERCISES

- 5.1.** Assume that $X = U \cup V$, where U and V are open subsets of X , and $U \cap V$ is nonempty and contractible. Express the homology groups of X in terms of those of U and V .
- 5.2.** Assume that $X = A \cup B$, where A and B are closed subsets of X , and $A \cap B = \{x_0\}$. Assume further that x_0 has an open neighborhood N in X such that $N \cap A$ and $N \cap B$ are both contractible, and that during the contraction the point x_0 remains fixed. Express the homology groups of X in terms of those of A and B .
- 5.3.** Assume that the space X and the subspaces A and B satisfy the hypotheses of Theorem 5.1. (a) Prove that the inclusion maps $(A, A \cap B) \rightarrow (X, B)$ and $(B, A \cap B) \rightarrow (X, A)$ induce isomorphisms on homology. (b) Show that the homomorphism $\Delta: H_n(X) \rightarrow H_{n-1}(A \cap B)$ is the composition of the following homomorphisms:

$$H_n(X) \xrightarrow{j_*} H_n(X, B) \approx H_n(A, A \cap B) \xrightarrow{\partial_*} H_{n-1}(A \cap B).$$

- 5.4.** Use the result of part (b) of the preceding exercise to *define* the homomorphism $\Delta: H_n(X) \rightarrow H_{n-1}(A \cap B)$. Then prove directly (by diagram chasing, without going back to chain groups) that the Mayer–Vietoris sequence is exact (cf. Eilenberg and Steenrod, [2, Chapter I]).

§6. The Jordan–Brouwer Separation Theorem and Invariance of Domain

The classical Jordan curve theorem may be stated as follows: Let C be a simple closed curve in the plane \mathbf{R}^2 , i.e., C is a subset of \mathbf{R}^2 which is homeomorphic to S^1 . Then $\mathbf{R}^2 - C$ has exactly two components, and C is the boundary of each component (in the sense of point set topology). It is our object in this section to prove a generalization of this theorem to \mathbf{R}^n , and derive various consequences. Most of the results of this section were first proved by the Dutch mathematician L. E. J. Brouwer.

The Mayer–Vietoris sequence will play an essential role in the proof. We will also need another general property of singular homology theory, which may be stated as follows:

Proposition 6.1. *Let (X, A) be a pair consisting of a topological space X and subspace A . (a) Given any homology class $u \in H_n(X, A)$, there exists a compact pair $(C, D) \subset (X, A)$ and a homology class $u' \in H_n(C, D)$ such that $i_*(u') = u$, where $i : (C, D) \rightarrow (X, A)$ is the inclusion map. (b) Let (C, D) be any compact pair such that $(C, D) \subset (X, A)$, and $v \in H_m(C, D)$ a homology class such that $i_*(v) = 0$. Then there exists a compact pair (C', D') such that $(C, D) \subset (C', D') \subset (X, A)$ and $j_*(v) = 0$, where $j : (C, D) \rightarrow (C', D')$ is the inclusion map.*

In the statement of this proposition, “a compact pair (C, D) ” means a pair such that C is compact and D is a compact subset of C . An inclusion relation between pairs, such as $(C, D) \subset (X, A)$, means that $C \subset X$ and $D \subset A$. For the reader who is familiar with the concept of direct limit, this proposition may be restated as follows: $H_n(X, A)$ is the direct limit of the groups $H_n(C, D)$, where (C, D) ranges over all compact pairs contained in (X, A) .

The proof of this proposition depends on the following fact: If $a \in Q_n(X)$, then there exists a compact set $C \subset X$ such that $a \in Q_n(C)$. In fact, if a is a linear combination of the singular n -cubes T_1, T_2, \dots, T_k , then we may choose $C = T_1(I^n) \cup T_2(I^n) \cup \dots \cup T_k(I^n)$. The proposition follows readily from this fact by choosing representative cycles for the homology classes involved, etc. The details can be easily worked out by the reader. We also leave it to the reader to verify that *this proposition remains true if we replace ordinary homology groups by reduced homology groups everywhere in the statement.*

In order to prove the Jordan–Brouwer separation theorem, we need the following lemma, which is of some interest in its own right:

Lemma 6.2. *Let Y be a subset of S^n which is homeomorphic to I^k , where $0 \leq k \leq n$. Then $\tilde{H}_i(S^n - Y) = 0$ for all i .*

PROOF. The proof is by induction on k . For $k = 0$, I^k is a single point (by definition), and $S^n - I^k$ is homeomorphic to \mathbf{R}^n , which is contractible.

In order to make the inductive step it is convenient to assume we have chosen a definite homeomorphism of Y with I^k ; then we may as well identify Y with I^k by means of this homeomorphism. Let

$$Y_0 = \{(x_1, \dots, x_k) \in Y \mid x_1 \leq \frac{1}{2}\},$$

$$Y_1 = \{(x_1, \dots, x_k) \in Y \mid x_1 \geq \frac{1}{2}\}.$$

Then

$$Y_0 \cup Y_1 = Y,$$

$$S^n - (Y_0 \cap Y_1) = (S^n - Y_0) \cup (S^n - Y_1),$$

and we may apply the Mayer–Vietoris sequence to this representation of $S^n - (Y_0 \cap Y_1)$ as the union of two open subsets. Note that $Y_0 \cap Y_1$ is homeomorphic to I^{k-1} ; hence, by the inductive hypothesis

$$\tilde{H}_i(S^n - (Y_0 \cap Y_1)) = 0$$

for all i . Therefore, we conclude from the exactness of the Mayer–Vietoris sequence that

$$\varphi : \tilde{H}_i(S^n - Y) \rightarrow \tilde{H}_i(S^n - Y_0) \oplus \tilde{H}_i(S^n - Y_1)$$

is an isomorphism for all i .

Now recall the definition of the homomorphism φ from the preceding section:

$$\varphi(x) = (i_{0*}(x), i_{1*}(x)),$$

where $i_0 : S^n - Y \rightarrow S^n - Y_0$ and $i_1 : S^n - Y \rightarrow S^n - Y_1$ are inclusion maps. In order to complete the proof of the inductive step, we will assume that for some integer i , $\tilde{H}_i(S^n - Y) \neq 0$, and show that this assumption leads to a contradiction. As a first consequence of the assumption that $\tilde{H}_i(S^n - Y) \neq 0$, we see that we can find an element $a_0 \in \tilde{H}_i(S^n - Y)$ such that $i_{0*}(a_0) \neq 0$, or $i_{1*}(a_0) \neq 0$.

Let us first take up the case where $a_1 = i_{0*}(a_0) \neq 0$. Let

$$Y_{00} = \{(x_1, \dots, x_k) \in Y_0 \mid 0 \leq x_1 \leq \frac{1}{4}\},$$

$$Y_{01} = \{(x_1, \dots, x_k) \in Y_0 \mid \frac{1}{4} \leq x_1 \leq \frac{1}{2}\}.$$

Then

$$Y_0 = Y_{00} \cup Y_{01}.$$

Let

$$i_{00} : S^n - Y_0 \rightarrow S^n - Y_{00},$$

$$i_{01} : S^n - Y_0 \rightarrow S^n - Y_{01}.$$

Then by a repetition of the above argument using the Mayer–Vietoris sequence and the inductive hypothesis, we may prove that $i_{00*}(a_1) \neq 0$ or

$i_{01*}(a_1) \neq 0$. In the other case where $i_{1*}(a_0) \neq 0$, we may represent Y_1 as the union of two subsets,

$$Y_1 = Y_{10} \cup Y_{11}$$

such that $i_{10*}(a_1) \neq 0$, or $i_{11*}(a_1) \neq 0$ where now $a_1 = i_{1*}(a_0) \neq 0$.

The reader will immediately see that we may continue this process *ad infinitum*. The net result is that we can construct an infinite decreasing sequence of subsets of Y each homeomorphic to I^k and denoted by

$$Y \supset Y' \supset Y'' \supset \cdots \supset Y^{(m)} \supset \cdots$$

such that the following two properties hold:

- (a) Let Y^∞ denote the intersection of all the sets of this sequence; then Y^∞ is homeomorphic to I^{k-1} . Hence, $\tilde{H}_j(S^n - Y^\infty) = 0$ for all j by our inductive hypothesis.
- (b) Let us denote the complementary sets and their inclusion maps as follows:

$$S^n - Y \xrightarrow{i} S^n - Y' \xrightarrow{i'} S^n - Y'' \xrightarrow{i''} \cdots$$

Using the element $a_0 \in \tilde{H}_i(S^n - Y)$, we may construct an infinite sequence

$$(a_0, a_1, a_2, \dots)$$

of elements such that $a_m \in \tilde{H}_i(S^n - Y^{(m)})$ and $a_m \neq 0$ as follows:

$$\begin{aligned} a_1 &= i_*(a_0), \\ a_2 &= i'_*(a_1), \\ a_3 &= i''_*(a_2), \quad \text{etc.} \end{aligned}$$

We will complete the proof by showing that the existence of such an infinite sequence of nonzero elements contradicts Proposition 6.1. Apply Proposition 6.1(a) to obtain a compact set $C \subset S^n - Y$ and a homology class $a'_0 \in \tilde{H}_i(C)$ such that $a'_0 \rightarrow a_0$ under the inclusion map $C \rightarrow (S^n - Y)$. Since $\tilde{H}_i(S^n - Y^\infty) = 0$, we may apply Proposition 6.1(b) to the inclusion $C \subset S^n - Y^\infty$ to conclude that there exists a compact set C' such that

$$C \subset C' \subset S^n - Y^\infty$$

and $a'_0 \rightarrow 0$ under the homomorphism induced by the inclusion map $C \rightarrow C'$. Since C' is compact, there exists an integer m such that $C' \subset S^n - Y^{(m)}$. Now consider the following diagram of reduced homology groups:

$$\begin{array}{ccc} \tilde{H}_i(C) & \longrightarrow & \tilde{H}_i(C') \\ \downarrow & & \downarrow \\ \tilde{H}_i(S^n - Y) & \longrightarrow & \tilde{H}_i(S^n - Y^{(m)}) \end{array}$$

All homomorphisms in this diagram are induced by inclusion maps, hence the

diagram is commutative. If we consider the element $a'_0 \in \tilde{H}_i(C)$ and chase it both ways around this diagram, we see that it must go to zero one way, while the other way it goes to $a_m \neq 0$. This is the desired contradiction, and hence the proof of the inductive step is complete. Q.E.D.

Perhaps the reader wonders who concocted such a complicated proof as this. The answer is that it is the work of many mathematicians; it has evolved over a relatively long portion of the history of algebraic topology. In order to appreciate why the proof of this lemma might have to be so complicated, the reader should consider some examples of subsets Y of S^3 which are homeomorphic to I^1 and such that $S^3 - I^1$ has a nontrivial fundamental group (cf. Artin and Fox [1]).

Theorem 6.3. *Let A be a subset of S^n which is homeomorphic to S^k , $0 \leq k \leq n - 1$. Then $\tilde{H}_{n-k-1}(S^n - A) = \mathbf{Z}$, and $\tilde{H}_i(S^n - A) = 0$ for $i \neq n - k - 1$.*

PROOF. Once again the proof is by induction on k , using the Mayer–Vietoris sequence. If $k = 0$, then A consists of two points and $S^n - A$ is homeomorphic to \mathbf{R}^n with one point removed. Hence $S^n - A$ has the homotopy type of S^{n-1} , and the theorem is true for this case.

Now we will make the inductive step. Since A is homeomorphic to S^k , it follows that $A = A_1 \cup A_2$, where A_1 and A_2 are subsets of A which are homeomorphic to I^k , and $A_1 \cap A_2$ is homeomorphic to S^{k-1} (cf. the proof of Theorem 2.1). Therefore,

$$S^n - (A_1 \cap A_2) = (S^n - A_1) \cup (S^n - A_2),$$

and we may apply the Mayer–Vietoris sequence to this representation of $S^n - (A_1 \cap A_2)$ as the union of two open subsets. By the lemma just proved,

$$\tilde{H}_i(S^n - A_1) = \tilde{H}_i(S^n - A_2) = 0$$

for all i . It follows from the exactness of the Mayer–Vietoris sequence that

$$\Delta : \tilde{H}_{i+1}(S^n - (A_1 \cap A_2)) \rightarrow \tilde{H}_i(S^n - A)$$

is an isomorphism for all i . Since $A_1 \cap A_2$ is homeomorphic to S^{k-1} , this isomorphism suffices to prove the inductive step. Q.E.D.

Examples

6.1. Suppose that A is a subset of S^3 which is homeomorphic to S^1 , i.e., A is a simple closed curve in S^3 . It follows from the theorem just proved that $\tilde{H}_1(S^3 - A)$ is infinite cyclic, and $\tilde{H}_i(S^3 - A) = 0$ for $i \neq 1$. It is well known that a simple closed curve in \mathbf{R}^3 or S^3 can be “knotted” in various different ways, or left unknotted. Thus the homology groups of $S^3 - A$ in this case are independent of how A is knotted. On the other hand, it may be shown that the fundamental group of $S^3 - A$ does depend on how A is knotted; cf. Chapter

IV, §6, and the references given there. The fact that the homology groups of $S^3 - A$ are independent of how A is knotted can be an advantage or a disadvantage, depending on what one is trying to do.

Corollary 6.4 (Jordan–Brouwer theorem). *Let A be a subset of S^n which is homeomorphic to S^{n-1} . Then $S^n - A$ has exactly two components.*

PROOF. Apply the case $k = n - 1$ of the preceding theorem to conclude that $H_0(S^n - A)$ has rank 2; hence $S^n - A$ has exactly two arc components. But it is readily seen that $S^n - A$ is locally arcwise connected, hence the components and arc components are the same.

Proposition 6.5. *Let A be a subset of S^n which is homeomorphic to S^{n-1} . Then A is the boundary of each component of $S^n - A$.*

In order to better appreciate this proposition, consider the case where A is a subset of S^2 which is homeomorphic to $S^1 \times I$ (instead of S^1). Then $S^2 - A$ has two components, but the boundary of either component is a *proper* subset of A .

PROOF OF PROPOSITION 6.5. Since $S^n - A$ is locally connected, each component of $S^n - A$ is an open subset of $S^n - A$, and hence an open subset of S^n . Therefore, the boundary of each component must be a subset of A . To complete the proof of the proposition, we must show that any point $a \in A$ is a boundary point of each component of $S^n - A$. Denote the components of $S^n - A$ by C_0 and C_1 . Let N be any open neighborhood of a in S^n ; we must show that $N \cap C_i \neq \emptyset$ for $i = 0$ and 1 .

Note that $N \cap A$ is an open neighborhood of a in A . Since A is homeomorphic to S^{n-1} , we can find a decomposition

$$A = A_1 \cup A_2,$$

as in the proof of Theorem 6.3, such that A_1 and A_2 are homeomorphic to I^{n-1} , $A_1 \cap A_2$ is homeomorphic to S^{n-2} , and $A_2 \subset N \cap A$. It follows from Lemma 6.2 that $S^n - A_1$ is arcwise connected. Let $p_0 \in C_0$, and $p_1 \in C_1$; choose an arc in $S^n - A_1$ joining p_0 to p_1 , i.e., a continuous map $f: I \rightarrow S^n - A_1$ such that $f(0) = p_0$, and $f(1) = p_1$. It follows from what we have already proved that $f(I) \cap A \neq \emptyset$, and hence $f(I) \cap A_2 \neq \emptyset$. Consider the subset $f^{-1}(A_2) \subset I$; this is a compact subset of I , and hence it must have a least point t_0 and a greatest point t_1 . Obviously t_0 and t_1 are boundary points of $f^{-1}(A_2)$, and $f^{-1}(N)$ is an open subset of I which contains both t_1 and t_2 . From this it follows by an easy argument that $f^{-1}(N) \cap f^{-1}(C_1)$ and $f^{-1}(N) \cap f^{-1}(C_0)$ are both nonempty. Hence, $N \cap C_1 \neq \emptyset$ and $N \cap C_0 \neq \emptyset$, as desired. Q.E.D.

Note that essential role that Lemma 6.2 plays in this proof.

In order to better appreciate the significance of Corollary 6.4 and Proposition 6.5, the reader should study the Alexander horned sphere or other wild

imbeddings of S^2 in S^3 , cf. Hocking and Young, [3, p. 176]. For the case of imbeddings of S^1 in S^2 , there is the so-called Schönflies theorem, which is stronger than the Jordan curve theorem (see E. Moise [4]).

Next, we will prove another of L. E. J. Brouwer's theorems, usually referred to as "the theorem on invariance of domain."

Theorem 6.6. *Let U and V be homeomorphic subsets of S^n . If U is open, then so is V (and conversely).*

PROOF. Let $h : U \rightarrow V$ be a homeomorphism. For any point $x \in U$ we can find a closed neighborhood N of x in U such that N is homeomorphic to I^n and its boundary, \dot{N} , is homeomorphic to S^{n-1} . Let $y = h(x)$; then $N' = h(N)$ is a closed neighborhood of y in V with boundary $\dot{N}' = h(\dot{N})$. It follows from Lemma 6.2 that $S^n - N'$ is connected, and from Theorem 6.4 that $S^n - \dot{N}'$ has exactly two components. Note that $S^n - \dot{N}'$ is the disjoint union of $N' - \dot{N}'$ and $S^n - N'$; since both of these sets are connected, they are the components of $S^n - \dot{N}'$. Therefore, both of them are open subsets of $S^n - \dot{N}'$ and hence of S^n . In particular, $N' - \dot{N}'$ is an open neighborhood of y which is entirely contained in V . Therefore, y is an interior point of V . Since this argument obviously applies to any point $y \in V$, the proof is complete. Q.E.D.

Brouwer's theorem on invariance of domain is a powerful theorem, and it deserves to be better known. It should be looked on as a very special topological property of S^n ; or more generally, of n -dimensional manifolds. (See the exercises below.)

Corollary 6.7. *Let A and B be arbitrary subsets of S^n , and let $h : A \rightarrow B$ be a homeomorphism. Then h maps interior points onto interior points, and boundary points onto boundary points.*

This corollary shows that the property of being an interior or boundary point of a subset $A \subset S^n$ is an intrinsic property, independent of the imbedding.

Lemma 6.2 and Theorem 6.3 are special cases of the Alexander duality theorem, which will be taken up in Chapter XIV.

EXERCISES

- 6.1. Let Y be a subset of \mathbf{R}^n which is homeomorphic to I^k , $0 \leq k \leq n$. Determine the homology groups of $\mathbf{R}^n - Y$. (HINT: Consider \mathbf{R}^n as the complement of a point in S^n .)
- 6.2. Let A be a subset of \mathbf{R}^n which is homeomorphic to S^k , $0 \leq k \leq n - 1$. Determine the homology groups of $\mathbf{R}^n - A$. How many components does $\mathbf{R}^n - A$ have?
- 6.3. Does the analogue of Proposition 6.5 hold true for subsets of \mathbf{R}^n which are homeomorphic to S^{n-1} ?
- 6.4. Let A be a closed subset of \mathbf{R}^n which is homeomorphic to \mathbf{R}^{n-1} . Prove that $\mathbf{R}^n - A$ has exactly two components.

- 6.5.** Prove that Theorem 6.6 and Corollary 6.7 hold for subsets of \mathbf{R}^n . Then prove the following more general form of Brouwer's theorem. Assume M and N are n -dimensional manifolds; let U and V be subsets of M and N , respectively, such that U and V are homeomorphic. If U is an open subset of M , then V is an open subset of N . (NOTE: An n -dimensional manifold is a Hausdorff space such that each point has an open neighborhood which is homeomorphic to \mathbf{R}^n .)
- 6.6.** Use Brouwer's theorem on invariance of domain to prove that \mathbf{R}^m and \mathbf{R}^n are not homeomorphic if $m \neq n$ (it is not necessary to use homology theory in this proof).
- 6.7.** Prove that if $m > n$, then there is no subset of S^n which is homeomorphic to I^m .
- 6.8.** Let U be an open subset of \mathbf{R}^n , and let $f: U \rightarrow \mathbf{R}^n$ be a map which is continuous and one-to-one. Prove that f is a homeomorphism of U onto $f(U)$.
- 6.9.** Prove that no *proper* subset of S^n can be homeomorphic to S^n .
- 6.10.** Prove that a continuous map $f: S^n \rightarrow \mathbf{R}^n$ cannot be one-to-one.
- 6.11.** Let U be an open subset of \mathbf{R}^m . Prove that if $m > n$, there is no continuous, one-to-one map of U into \mathbf{R}^n . Generalize this statement by replacing \mathbf{R}^m and \mathbf{R}^n by manifolds of dimension m and n respectively.
- 6.12.** Let A and B be subsets of S^n which are homeomorphic to S^p and S^q , respectively, where $0 < p \leq q < n$. Determine the homology groups of $S^n - (A \cup B)$ in the following two cases:
- A and B are disjoint subsets of S^n .
 - $A \cap B$ consists of exactly one point.
- In case $p = q = n - 1$, determine the number of components of $S^n - (A \cup B)$.
- 6.13.** Let A and B be homeomorphic subsets of \mathbf{R}^n . If A is closed, does it follow that B is closed?
- 6.14.** Let X be a subset of S^3 which is a finite, connected, regular graph (see Definition 3.1). Prove that $H_1(S^3 - X)$ is a free abelian group of the same rank as $H_1(X)$ and that $H_q(S^3 - X) = 0$ for $q > 1$. [HINT: Use induction on the number of edges of X . Any finite connected graph X has an edge e such that the closure (in X) of $X - \bar{e}$ is a connected graph Y having one less edge; and Y may have either one or two vertices in common with e .]

§7. The Relation Between the Fundamental Group and the First Homology Group*

The main theorem of this section asserts that for an arcwise-connected space, the fundamental group completely determines the first homology group. The precise statement will be given after some preliminary definitions. It is assumed

* This section may be omitted by readers who are not familiar with the properties of the fundamental group.

that the reader is familiar with the basic properties of the fundamental group; cf. Chapter II. We will consider the fundamental group as a multiplicative group and $H_1(X)$ as an additive group.

First of all, for any topological space X and any base point $x_0 \in X$ we define a homomorphism

$$h_X : \pi(X, x_0) \rightarrow H_1(X)$$

as follows. Let $\alpha \in \pi(X, x_0)$; choose a closed path $f : I \rightarrow X$ belonging to the equivalence class α . We can think of f as a singular 1-cube, and hence as determining an element of the chain group $C_1(X)$. Since $f(0) = f(1) = x_0$, $\partial_1(f) = 0$; in other words, f is a cycle. We define $h_X(\alpha)$ to be the homology class of the cycle f . To see that $h_X(\alpha)$ is well defined, one must verify that if $g : I \rightarrow X$ is another closed path in the equivalence class α , then the cycles f and g belong to the same homology class. We leave this verification to the reader. Next, one should check that h_X is a homomorphism, i.e., $h_X(\alpha \cdot \beta) = h_X(\alpha) + h_X(\beta)$. This may be done as follows. Choose representatives $f : I \rightarrow X$ and $g : I \rightarrow X$ for α and β , respectively. Then $f \cdot g : I \rightarrow X$ is a representative for $\alpha \cdot \beta$, where

$$(f \cdot g)t = \begin{cases} f(2t), & 0 \leq t \leq \frac{1}{2} \\ g(2t - 1), & \frac{1}{2} \leq t \leq 1. \end{cases}$$

Now define a singular 2-cube $T : I^2 \rightarrow X$ by the formula

$$T(x_1, x_2) = \begin{cases} f(x_1 + 2x_2), & x_1 + 2x_2 \leq 1 \\ g\left(\frac{x_1 + 2x_2 - 1}{x_1 + 1}\right), & x_1 + 2x_2 \geq 1. \end{cases}$$

The function T was chosen so that it is constant along the straight lines shown in Figure 8.7. It is readily checked that

$$\partial_2(T) = f + g - f \cdot g - c,$$

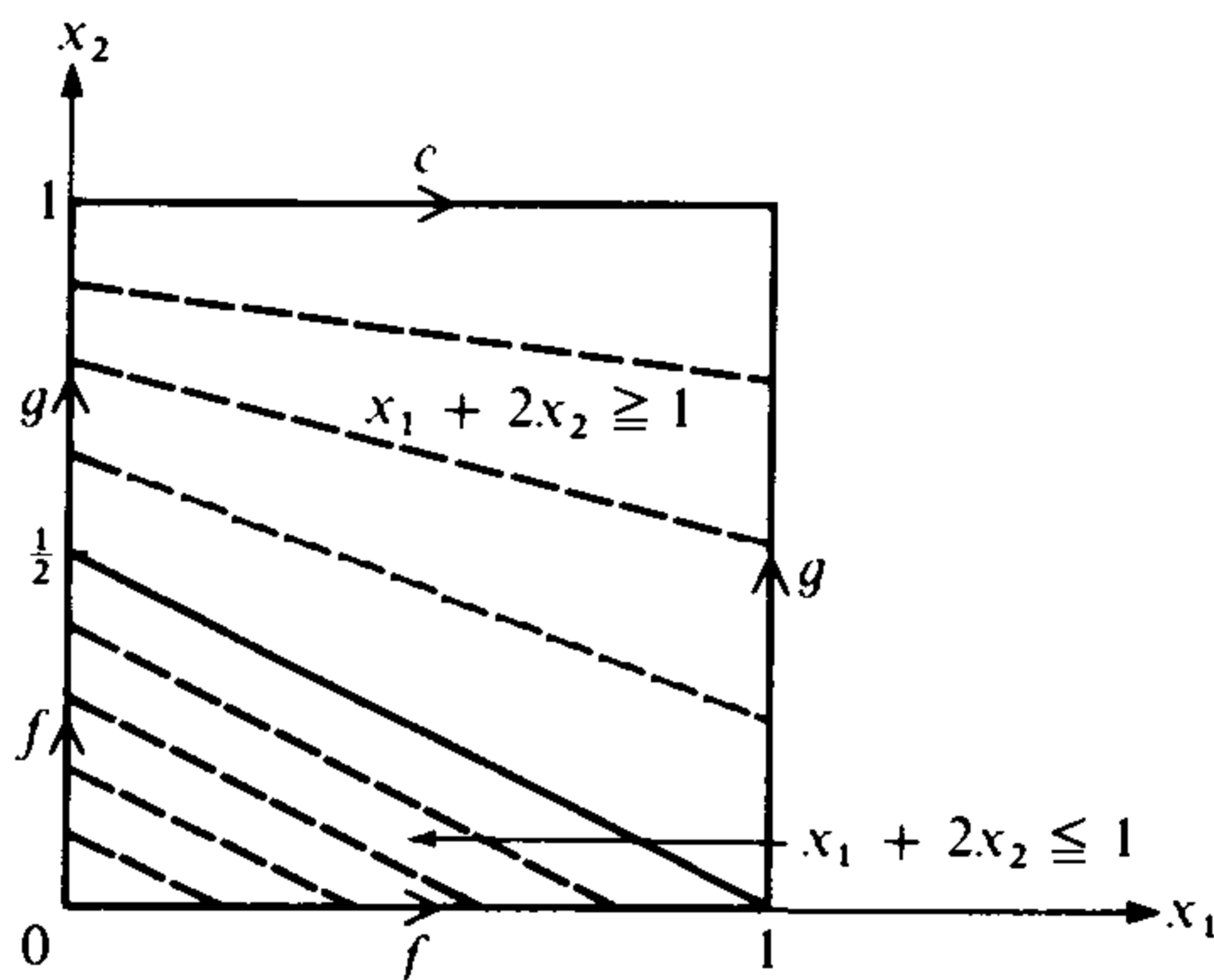

FIGURE 8.7

where c is a degenerate singular 1-cube. But this equation clearly implies that $h_X(\alpha \cdot \beta) = h_X(\alpha) + h_X(\beta)$, as required. In order to better understand the definition of the function T , it is suggested that the reader try to work out the formula for $T(x_1, x_2)$ himself so that it will have the required properties.

The homomorphism we have just defined satisfies the following obvious naturality condition. Let $\varphi : X \rightarrow Y$ be a continuous map such that $\varphi(x_0) = y_0$. Then the following diagram is commutative:

$$\begin{array}{ccc}
 \pi(X, x_0) & \xrightarrow{\varphi_*} & \pi(Y, y_0) \\
 \downarrow h_X & & \downarrow h_Y \\
 H_1(X) & \xrightarrow{\varphi_*} & H_1(Y)
 \end{array}$$

In addition, the following two rather obvious remarks apply to the homomorphism h .

(a) If the space X is not arcwise connected, $H_1(X)$ is the direct sum of the groups $H_1(X_\lambda)$, where $\{X_\lambda | \lambda \in A\}$ denotes the set of arc components of X . It is obvious that the image of the homomorphism h_X is entirely contained in the 1-dimensional homology group of the arc component of X which contains the basepoint x_0 . Therefore, the homomorphism h_X is mainly of interest in the case of arcwise-connected spaces.

(b) Since $H_1(X)$ is abelian, the commutator subgroup of $\pi(X, x_0)$ is contained in the kernel of h_X . Let us use the notation $\pi'(X, x_0)$ to denote the "abelianized" fundamental group, i.e., the quotient group of $\pi(X, x_0)$ modulo its commutator subgroup. Then h_X induces a homomorphism $\pi'(X, x_0) \rightarrow H_1(X)$, which we will denote by the same symbol, h_X , or h for short.

With these properties out of the way, we can state the main result of this section:

Theorem 7.1. *Let X be an arcwise-connected space. Then h is an isomorphism of the abelianized fundamental group $\pi'(X, x_0)$ onto $H_1(X)$.*

PROOF. In order to carry out the proof, it is convenient to show that one can compute the singular homology groups of an arcwise-connected space X using only those singular cubes which have all their vertices mapped into the basepoint x_0 . There is a certain analogy here with Theorem VII.6.4.

Let $Q_n(X/x_0)$ denote the subgroup of $Q_n(X)$ generated by all singular n -cubes $T : I^n \rightarrow X$ such that $T(v) = x_0$ for any vertex v of the cube I^n . Define $D_n(X/x_0) = D_n(X) \cap Q_n(X/x_0)$ and $C_n(X/x_0) = Q_n(X/x_0)/D_n(X/x_0)$. Note that the boundary operator $\partial_n : Q_n(X) \rightarrow Q_{n-1}(X)$ obviously maps the subgroup $Q_n(X/x_0)$ into $Q_{n-1}(X/x_0)$, and hence it induces a boundary operator $\partial_n : C_n(X/x_0) \rightarrow C_{n-1}(X/x_0)$. As usual, we define the group of n -cycles, $Z_n(X/x_0)$, to be the kernel of ∂_n ,

$$Z_n(X/x_0) = \{u \in C_n(X/x_0) | \partial_n(u) = 0\},$$

and the group of bounding cycles $B_n(X/x_0)$ to be $\partial_{n+1}(C_{n+1}(X/x_0))$. Then $B_n(X/x_0) \subset Z_n(X/x_0)$ and we define

$$H_n(X/x_0) = Z_n(X/x_0)/B_n(X/x_0).$$

The inclusion $Q_n(X/x_0) \subset Q_n(X)$ induces homomorphisms

$$\tau_n : C_n(X/x_0) \rightarrow C_n(X)$$

and

$$\tau_* : H_n(X/x_0) \rightarrow H_n(X).$$

Lemma 7.2. *If the space X is arcwise connected, then the homomorphism τ_* is an isomorphism for all n .*

PROOF OF LEMMA. The strategy of the proof is to show that the system of subgroups $C_n(X/x_0)$, $n = 0, 1, 2, \dots$ is a “deformation retract” of the full chain groups $C_n(X)$, $n = 0, 1, 2, \dots$, in some algebraic sense. To be precise, we will define a sequence of homomorphisms $\rho_n : C_n(X) \rightarrow C_n(X/x_0)$ such that the ρ_n 's commute with the boundary operators and hence induce homomorphisms $\rho_* : H_n(X) \rightarrow H_n(X/x_0)$. It will turn out that $\rho_n \tau_n$ is the identity map of $C_n(X/x_0)$ for each n ; hence, $\rho_* \tau_*$ is the identity map of $H_n(X/x_0)$. Finally, we will define a sequence of homomorphisms $\Phi_n : C_n(X) \rightarrow C_{n+1}(X)$ which will be a chain homotopy between the chain map $\tau_n \rho_n$ and the identity map of $C_n(X)$. Hence $\tau_* \rho_*$ is the identity map of $H_n(X)$, and the proof will be complete. Actually, we will only carry out this program for small values of n , because we only need to know that $\tau_* : H_1(X/x_0) \rightarrow H_1(X)$ is an isomorphism. The rest of the proof will be left as an exercise. Also, it turns out to be easiest to define the homomorphisms Φ_n first, and then define the homomorphisms ρ_n afterwards.

In order to define Φ_n , we will define homomorphisms $\varphi_n : Q_n(X) \rightarrow Q_{n+1}(X)$ such that $\varphi_n(D_n(X)) \subset D_{n+1}(X)$. We will do this in succession for $n = 0, 1, 2$. In each case, if T is a singular n -cube, $\varphi_n T$ will be a singular $n + 1$ cube. We proceed as follows:

Case $n = 0$. We can identify the singular 0-cubes with the points of X . For each $x \in X$ such that $x \neq x_0$, choose a path $T : I \rightarrow X$ such that $T(0) = x_0$ and $T(1) = x$, and then define $\varphi(x) = T$. Complete the definition by defining $\varphi(x_0)$ to be the degenerate singular 1-cube at x_0 . Note that

$$\partial_1 \varphi_0(x) = x - x_0$$

for any singular 0-cube x .

Case $n = 1$. Let $T : I \rightarrow X$ be a singular 1-cube; we have to define a singular 2-cube $\varphi_1 T : I^2 \rightarrow X$. We have already defined the chain homotopy φ_0 on the two faces $A_1 T$ and $B_1 T$, and we want the new definition to be consistent with what we have already defined. Therefore, we impose the following three conditions on $\varphi_1 T$:

$$\begin{aligned} B_1 \varphi_1 T &= T, \\ A_2 \varphi_1 T &= \varphi_0 A_1 T, \\ B_2 \varphi_1 T &= \varphi_0 B_1 T. \end{aligned}$$

Note that these conditions imply that $A_1 \varphi_1 T \in Q_1(X/x_0)$. Given a singular 1-cube T , there always exist singular 2-cubes $\varphi_1 T$ satisfying these three conditions because the subset of I^2 consisting of the union of any three edges is a retract of I^2 . Therefore, we may *define* φ_1 by choosing for each singular 1-cube T a singular 2-cube $\varphi_1 T$ satisfying these three conditions. We wish also to impose the following two additional conditions, which are consistent with the three we have already imposed, and with each other:

(a) If $T \in Q_1(X/x_0)$, i.e., if T maps both the vertices of I into x_0 , define $\varphi_1 T$ by

$$(\varphi_1 T)(x_1, x_2) = T(x_2).$$

Then $\varphi_1 T$ is degenerate.

(b) If T is a degenerate 1-cube, i.e., $T(x) = \text{constant}$, define

$$(\varphi_1 T)(x_1, x_2) = (\varphi_0 A_1 T)(x_1) = (\varphi_0 B_1 T)(x_1).$$

Then $\varphi_1 T$ is also degenerate.

Case $n = 2$. Given a singular 2-cube $T: I^2 \rightarrow X$ we wish to define $\varphi_2 T: I^3 \rightarrow X$ so that the definition is consistent with the definition of φ_1 on the four faces of T . Therefore, we impose the following conditions on $\varphi_2 T$:

$$\begin{aligned} B_1 \varphi_2 T &= T, \\ A_i \varphi_2 T &= \varphi_1 A_{i-1} T, \quad i = 2, 3, \\ B_i \varphi_2 T &= \varphi_1 B_{i-1} T, \quad i = 2, 3. \end{aligned}$$

Given T , there will always exist singular 3-cubes $\varphi_2 T$ satisfying these five conditions, because the union of any five faces of I^3 is a retract of I^3 . Define φ_2 by choosing for each 2-cube T a 3-cube $\varphi_2 T$ satisfying these five conditions: Note that $A_1 \varphi_2 T \in Q_2(X/x_0)$. We also impose the following two additional conditions, which are consistent with the previous five conditions and with each other:

(a) If $T \in Q_2(X/x_0)$, define $\varphi_2 T$ by

$$(\varphi_2 T)(x_1, x_2, x_3) = T(x_2, x_3).$$

Then $\varphi_2 T$ is degenerate in this case.

(b) If T is a degenerate 2-cube define $\varphi_2 T$ as follows. Since T is degenerate,

$$T(x_1, x_2) = A_1 T(x_2) = B_1 T(x_2)$$

or

$$T(x_1, x_2) = A_2 T(x_1) = B_2 T(x_1).$$

In the first case, define

$$\begin{aligned}\varphi_2 T(x_1, x_2, x_3) &= (\varphi_1 A_1 T)(x_1, x_3) \\ &= (\varphi_1 B_1 T)(x_1, x_3),\end{aligned}$$

whereas in the second case let

$$\begin{aligned}\varphi_2 T(x_1, x_2, x_3) &= (\varphi_1 A_2 T)(x_1, x_2) \\ &= (\varphi_1 B_2 T)(x_1, x_2).\end{aligned}$$

In either case, $\varphi_2 T$ is also degenerate.

The reader who so desires can define φ_n inductively, following the same pattern for the cases $n = 1$ and $n = 2$.

For $n = 1$ or 2 it is a routine matter to verify the following formula for any singular n -cube T :

$$\partial_{n+1} \varphi_n(T) = T - A_1 \varphi_n(T) - \varphi_{n-1} \partial_n(T);$$

whereas for $n = 0$ we have the simpler formula

$$\partial_1 \varphi_0(x) = x - x_0.$$

Therefore, we define $\rho_n : Q_n(X) \rightarrow Q_n(X/x_0)$ as follows: For $n = 0$,

$$\rho_0(x) = x_0$$

for any singular 0-cube x . For $n = 1$ or 2 ,

$$\rho_n(T) = A_1 \varphi_n(T).$$

With this notation, the preceding formulas can be written as follows:

$$\partial_1 \varphi_0(u) = u - \rho_0(u), \quad u \in Q_0(X), \quad (8.7.1)$$

$$\partial_{n+1} \varphi_n(u) + \varphi_{n-1} \partial_n(u) = u - \rho_n(u), \quad u \in Q_n(X), \quad n = 1 \text{ or } 2. \quad (8.7.2)$$

Note that ρ_n restricted to the subgroup $Q_n(X/x_0)$ is the identity map, and both φ_n and ρ_n map degenerate chains into degenerate chains. Therefore they define homomorphisms

$$\rho_n : C_n(X) \rightarrow C_n(X/x_0),$$

$$\Phi_n : C_n(X) \rightarrow C_{n+1}(X),$$

and analogues of Equations (8.7.1) and (8.7.2) hold. It remains to prove that ρ commutes with the boundary operator, i.e.,

$$\partial_n \rho_n(u) = \rho_{n-1} \partial_n(u).$$

This equation is an easy consequence of Equations (8.7.1) and (8.7.2): Apply ∂_n to both sides of Equation (8.7.2) and also substitute $\partial_{n+1}(u)$ for u in this equation, and compare the results.

This completes the proof of Lemma 7.2. This proof is conceptually quite simple, but the many details which need to be checked make it rather long.

Q.E.D.

We can now proceed with the proof of Theorem 7.1. First of all, note that $Z_1(X/x_0) = C_1(X/x_0)$; hence there is a natural epimorphism $k : C_1(X/x_0) \rightarrow H_1(X/x_0)$ and the kernel of k is $B_1(X/x_0)$.

Next, we will define a homomorphism $l : Q_1(X/x_0) \rightarrow \pi'(X/x_0)$ in a rather obvious way. Since $Q_1(X/x_0)$ is a free abelian group and $\pi'(X, x_0)$ is abelian, it suffices to define l on a basis for $Q_1(X/x_0)$, namely, on the singular 1-cubes. But each such basis element $T : I \rightarrow X$ with vertices at x_0 is a closed path and hence determines a unique element of $\pi(X, x_0)$. Note that l maps $D_1(X/x_0)$ trivially, and therefore induces a homomorphism $l' : C_1(X/x_0) \rightarrow \pi'(X, x_0)$, which is obviously an epimorphism. Also, the following diagram is clearly commutative:

$$\begin{array}{ccc}
 C_1(X/x_0) & \xrightarrow{l'} & \pi'(X, x_0) \\
 \downarrow k & & \downarrow h \\
 H_1(X/x_0) & \xrightarrow{\tau_*} & H_1(X)
 \end{array} \tag{8.7.3}$$

Since τ_* is an isomorphism it follows from this diagram that

$$\text{kernel } l' \subset \text{kernel } k = B_1(X/x_0).$$

We will next show that

$$B_1(X/x_0) \subset \text{kernel } l'; \tag{8.7.4}$$

from this it will follow that

$$\text{kernel } l' = \text{kernel } k,$$

and since both k and l' are epimorphisms, and Diagram (8.7.3) is commutative, h must be an isomorphism as desired.

To prove Inclusion (8.7.4), consider the following sequence of homomorphisms.

$$Q_2(X/x_0) \xrightarrow{\partial_2} Q_1(X/x_0) \xrightarrow{l'} \pi'(X, x_0).$$

By using a basic property of the fundamental group (cf. Lemma II.8.1) it is easy to prove that the composition $l'\partial_2 = 0$. From this fact Inclusion (8.7.4) follows. Q.E.D.

This theorem should help to develop one's intuition about the first homology group $H_1(X)$. If we apply this theorem with $X = S^1$, we have still another method of completing the proof of Theorem II.5.1 on the fundamental group of a circle.

EXERCISES

- 7.1. Assume that G is an arcwise-connected topological space, $e \in G$, and there exists a continuous map $\mu : G \times G \rightarrow G$ such that $\mu(e, x) = \mu(x, e) = x$ for any $x \in G$. [Example: G is a topological group and e is the identity.] Prove that $\pi(X, e)$ is isomorphic to $H_1(X)$ (cf. Exercise 7.5 of Chapter II).

NOTES

In all the examples in this chapter, the homology groups are finitely generated. In applications of homology theory this is quite often the case. If the group $H_q(X)$ is finitely generated, it is customary to call the rank of $H_q(X)$ the q th *Betti number of X* , and the torsion coefficients of $H_q(X)$ the q -dimensional *torsion coefficients of X* . (For the definition of the rank and torsion coefficients of a finitely generated abelian group, see §III.3.)

In the early years of algebraic topology, up until about 1930, the Betti numbers and torsion coefficients were the main objects of interest. For example, in 1922 Oswald Veblen published his monograph entitled *Analysis Situs* (American Mathematical Society Colloquium Lectures, Volume 5) and nowhere did he mention homology groups. The shift of emphasis from Betti numbers and torsion coefficients to the homology groups themselves was due mainly to the influence of Emmy Noether in the late 1920s.

References

1. E. Artin and R. H. Fox, Some wild cells and spheres in three-dimensional space, *Ann. Math.* **49** (1948), 979–990.
2. S. Eilenberg and N. E. Steenrod, *Foundations of Algebraic Topology*, Princeton University Press, Princeton, N.J., 1952.
3. J. G. Hocking and G. S. Young, *Topology*, Addison-Wesley, Reading, Mass., 1961.
4. E. Moise, *Geometric Topology in Dimensions 2 and 3*, Springer-Verlag, New York, 1977.

CHAPTER IX

Homology of CW-Complexes

§1. Introduction

The purpose of this chapter is to develop a systematic procedure for determining the homology groups of a certain class of topological spaces. The class of topological spaces chosen consists of the CW-complexes of J.H.C. Whitehead. The procedure developed is a natural generalization and extension of the method used in the preceding chapter to determine the homology groups of graphs and compact 2-manifolds.

§2. Adjoining Cells to a Space

The reader may have noticed that there was an analogy in the way the exact homology sequence and Excision property were applied in §VIII.3 to determine the homology groups of a graph, and the way they were applied in §VIII.4 to determine the homology groups of a compact surface. The reason behind this analogy may be stated as follows: A graph may be obtained by adjoining the edges to the vertices, and each edge is homeomorphic to \mathbf{R}^1 . A compact surface may be obtained by adjoining an open disc (which is homeomorphic to \mathbf{R}^2) to a certain graph (which is a union of one or more circles with a single point in common).

It is natural to expect there would be a higher-dimensional analogy of these two cases, in which one considers spaces which are obtained by adjoining higher-dimensional open “discs” or “open solid balls” to a given space, and then uses the Excision property, etc., in an analogous way to compute the homology groups of the resulting space. In this section we will study such a

higher-dimensional analogue. We will even consider the case where an infinite number of n -dimensional “discs” or “balls” are all attached at once.

In the next section, we will consider spaces that are built up one dimension at a time by first attaching open 2-dimensional discs to a graph (as in the case of a surface), then open 3-dimensional balls to the resulting space, etc.

In this and the following sections, we will use the following terminology and notation for any integer $n \geq 1$:

$$E^n = \{x \in \mathbf{R}^n \mid |x| \leq 1\} \quad (\text{closed } n\text{-dimensional disc or ball}),$$

$$U^n = \{x \in \mathbf{R}^n \mid |x| < 1\} \quad (\text{open } n\text{-dimensional disc or ball}),$$

$$S^{n-1} = \{x \in \mathbf{R}^n \mid |x| = 1\} \quad (n-1)\text{-dimensional sphere}.$$

The sphere S^{n-1} is called the “boundary” of E^n . Note that U^n is homeomorphic to \mathbf{R}^n , and that it is contractible.

In this section we assume that X^* is a Hausdorff space, and that X is a closed subset of X^* such that $X^* - X$ is the disjoint union of open subsets e_λ^n , $\lambda \in \Lambda$; each e_λ^n is assumed to be homeomorphic to U^n , and is called an n -cell or *open n -cell*. Finally, it is assumed that each n -cell e_λ^n is “attached” to X by means of a so-called *characteristic map*. This means that for each index $\lambda \in \Lambda$ there exists a continuous map

$$f_\lambda : E^n \rightarrow \bar{e}_\lambda^n$$

such that f_λ maps U^n homeomorphically onto e_λ^n and $f_\lambda(S^{n-1}) \subset X$.

If there are only a finite number of n -cells, then we need impose no other conditions. However, if the number of n -cells is infinite, then we must impose the following further condition in order to avoid various pathological situations: It is assumed that a subset A of X^* is closed if and only if $A \cap X$ and $f_\lambda^{-1}(A)$ are closed for all $\lambda \in \Lambda$. This last condition is often expressed by saying that “ X^* has the *weak topology* determined by the maps f_λ and the inclusion map $X \rightarrow X^*$.” Note that this condition is automatically satisfied in case the number of cells is finite (since the finite union of closed sets is closed in any topological space and a compact subset of a Hausdorff space is closed).

Intuitively speaking, we can think of the space X^* as obtained from X by the “pasting on” of the n -cells e_λ^n . The characteristic map f_λ describes precisely how the cell e_λ^n is pasted onto X . In Chapter VIII there were examples of the cases where $n = 1$ or 2 and the number of cells attached is finite. The reader should construct other examples to illustrate some of the various possibilities inherent in this definition.

In this section, we wish to consider the following problem. Suppose X is a space whose homology groups are known. Let X^* be a space obtained from X by adjoining n -cells so that the above conditions hold. How are the homology groups of X^* related to those of X ? The obvious way to attack this problem is to consider the exact sequence of the pair (X^*, X) . This requires that we determine the homology groups of the pair (X^*, X) . This we can do by application of the techniques of the last chapter. The result may be stated as follows:

Theorem 2.1. *Let X^* be a space obtained by attaching a collection of n -cells ($n > 0$) $\{e_\lambda^n | \lambda \in \Lambda\}$ to X so that the hypotheses listed above hold. Then $H_q(X^*, X) = 0$ for all $q \neq n$. For each index $\lambda \in \Lambda$, the characteristic map f_λ induces a monomorphism of relative homology groups $f_{\lambda*} : H_n(E^n, S^{n-1}) \rightarrow H_n(X^*, X)$ and $H_n(X^*, X)$ is the direct sum of the image subgroups. Thus, $H_n(X^*, X)$ is a free abelian group with basis in 1-1 correspondence with the set of cells $\{e_\lambda^n | \lambda \in \Lambda\}$.*

Corollary 2.2. *The homomorphism $i_* : H_q(X) \rightarrow H_q(X^*)$ is an isomorphism except possibly for $q = n$ and $q = n - 1$; the only nontrivial part of the homology sequence of the pair (X^*, X) is the following:*

$$0 \rightarrow H_n(X) \xrightarrow{i_*} H_n(X^*) \rightarrow H_n(X^*, X) \rightarrow H_{n-1}(X) \xrightarrow{i_*} H_{n-1}(X^*) \rightarrow 0.$$

PROOF OF THEOREM 2.1. The closed ball E^n and the sphere S^{n-1} both have center at the origin, 0, and radius 1. We also need to consider the closed ball of radius $\frac{1}{2}$ with center at the origin:

$$D^n = \{x \in \mathbf{R}^n | |x| \leq \frac{1}{2}\}.$$

Let

$$D_\lambda = f_\lambda(D^n),$$

$$a_\lambda = f_\lambda(0),$$

$$\mathcal{D} = \bigcup_{\lambda \in \Lambda} D_\lambda,$$

$$A = \{a_\lambda | \lambda \in \Lambda\},$$

$$X' = X^* - A.$$

Note that f_λ maps the pair $(D^n, D^n - \{0\})$ homeomorphically onto $(D_\lambda, D_\lambda - \{a_\lambda\})$, and that the subsets D_λ , $\lambda \in \Lambda$, are pairwise disjoint. Consider the following diagram:

$$H_q(\mathcal{D}, \mathcal{D} - A) \xrightarrow{1} H_q(X^*, X') \xleftarrow{2} H_q(X^*, X),$$

where both arrows denote homomorphisms induced by inclusion maps. We assert that both homomorphisms in this diagram are isomorphisms for all q . For the homomorphism represented by arrow 2, this follows from the fact that X is a deformation retract of X' , and by using the five-lemma. For the homomorphism represented by arrow 1, it is a consequence of the excision property.

Next, note that the arcwise-connected components of \mathcal{D} are obviously the sets D_λ . Hence $H_q(\mathcal{D}, \mathcal{D} - \Lambda)$ is the direct sum of the groups $H_q(D_\lambda, D_\lambda - \{a_\lambda\})$ for all $\lambda \in \Lambda$. Moreover,

$$H_q(D_\lambda, D_\lambda - \{a_\lambda\}) = \begin{cases} 0 & \text{for } q \neq n \\ \mathbf{Z} & \text{for } q = n. \end{cases}$$

From this it follows that $H_q(X^*, X) = 0$ for $q \neq n$, and that $H_n(X^*, X)$ is a free abelian group with basis in 1-1 correspondence with the set of n -cells $\{e_\lambda^n\}$. To complete the proof, consider the following commutative diagram:

$$\begin{array}{ccccc}
 H_n(\mathcal{D}, \mathcal{D} - A) & \xrightarrow{1} & H_n(X^*, X') & \xleftarrow{2} & H_n(X^*, X) \\
 \uparrow f'_{\lambda*} & & \uparrow f''_{\lambda*} & & \uparrow f_{\lambda*} \\
 H_n(D^n, D^n - \{0\}) & \xrightarrow{3} & H_n(E, E^n - \{0\}) & \xleftarrow{4} & H_n(E^n, S^{n-1})
 \end{array}$$

The vertical arrows denote homomorphisms induced by f_λ . Since f_λ maps $(D^n, D^n - \{0\})$ homeomorphically onto $(D_\lambda, D_\lambda - \{a_\lambda\})$, it follows that $f'_{\lambda*}$ maps $H_n(D^n, D^n - \{0\})$ isomorphically onto the direct summand $H_n(D_\lambda, D_\lambda - \{a_\lambda\})$ of $H_n(\mathcal{D}, \mathcal{D} - A)$. We have already proved that arrows 1 and 2 are isomorphisms; by exactly the same method, one can prove that arrows 3 and 4 are isomorphisms. Putting all these facts together suffices to prove that $f_{\lambda*} : H_n(E^n, S^{n-1}) \rightarrow H_n(X^*, X)$ has the desired properties. Q.E.D.

To close this section, we call the reader's attention to the naturality of the exact sequence of the pair (X^*, X) . Thus, if X^* is obtained from X by the adjunction of n -cells, and Y^* is similarly obtained from Y by the adjunction of n -cells, and $\varphi : (X^*, X) \rightarrow (Y^*, Y)$ is a continuous map of pairs, then we get a ladderlike commutative diagram of maps of the homology sequence of (X^*, X) into that of (Y^*, Y) . Of course this is a special case of naturality of the exact sequence of a pair, but it is important and we will make use of it.

§3. CW-Complexes

One of the problems encountered in a systematic exposition of algebraic topology is deciding on a suitable category of spaces to be studied. If the category chosen is too narrow and restricted, the theorems are not likely to be applicable in other parts of mathematics. On the other hand, if the category chosen is too broad and inclusive, many of the theorems one desires to prove will become very difficult or false (algebraic topology is mainly concerned with topological spaces which are sufficiently nice locally so as to be nonpathological). The category of CW-complexes (introduced by J. H. C. Whitehead in 1949) has proven to be a reasonable compromise between the various extremes. Roughly speaking, a CW-complex is built up by the successive adjunction of cells of dimensions 1, 2, 3, ..., etc., as described in the preceding section. Our treatment of this topic is rather brief; hence it may be advisable for the student to read further on this topic. The original paper on the subject is by J. H. C. Whitehead [10]. The book by Lundell and Weingram [5] is rather complete. Other references are Cooke and Finney [2, Chapter I], Hilton [3], Hu [4], and Massey [6].

The original reason for the term “CW-complex” may be explained as follows: The letter C stands for *closure-finite* and W stands for *weak topology*.

Definition 3.1. A structure of CW-complex is prescribed on a space X (which is *always* assumed to be Hausdorff) by the prescription of an ascending sequence of *closed* subspaces

$$X^0 \subset X^1 \subset X^2 \subset \dots$$

which satisfy the following conditions:

- (i) X^0 has the discrete topology.
- (ii) For $n > 0$, X^n is obtained from X^{n-1} by adjoining a collection of n -cells so that the conditions explained in §2 hold.
- (iii) X is the union of the subspaces X^i for $i \geq 0$.
- (iv) The space X and the subspaces X^n all have the weak topology: A subset A is closed if and only if $A \cap \bar{e}^n$ is closed for all n -cells, e^n , $n = 0, 1, 2, \dots$.

The subset X^n is called the *n-skeleton*. The points of X^0 are called *vertices* or 0-cells. A CW-complex is *finite* or *infinite* according as the number of cells is finite or infinite. If $X = X^n$ for some integer n , the CW-complex is called *finite dimensional*, and the least such integer n is called the *dimension*.

Note that for finite CW-complexes, condition (iv) is superfluous. This fact greatly simplifies the theory in the finite case, which will be our main interest.

Examples

3.1. The n -sphere, S^n , can be given a CW-complex structure such that there are only two cells, a 0-cell and an n -cell. In other words, the k -skeleton is a single point for $0 \leq k < n$, and the n -skeleton is S^n . The characteristic map, by which the n -cell is attached, maps the boundary of E^n to a single point.

3.2. A finite graph, as defined in §VIII.3, is a finite, 1-dimensional CW-complex with an additional condition imposed on the characteristic maps by which the 1-cells are attached.

3.3. In §VIII.3 we determined the homology groups of a compact, orientable surface of genus $g > 0$ (i.e., the connected sum of g tori). This amounted to prescribing a finite, 2-dimensional CW-complex structure on each of these surfaces, such that there is a single 0-cell, $2g$ 1-cells, and a single 2-cell. In the case of a nonorientable surface of genus g (i.e., the connected sum of g projective planes) we used a CW-complex having a single 0-cell, g 1-cells, and a single 2-cell.

3.4. To *triangulate* a compact 2-manifold, as explained in Chapter I, gives it the structure of a finite, 2-dimensional CW-complex. The vertices are the 0-cells, the edges are the 1-cells, and the triangles are the 2-cells. Similarly, the more general subdivision of a compact 2-manifold discussed in §VI.8 also gives rise to a CW-complex.

3.5. Suppose that X and Y are finite CW-complexes with skeletons $\{X^k\}$ and $\{Y^k\}$, respectively. Then one can specify a CW-complex on the product space $X \times Y$ such that the n -skeleton is the union of the subspaces $X^0 \times Y^n$, $X^1 \times Y^{n-1}$, $X^2 \times Y^{n-2}$, ..., $X^n \times Y^0$. The product of a p -cell of X and a q -cell of Y is a $p + q$ -cell of $X \times Y$; the attaching map of such a product cell is the product of the attaching maps. The details of this construction will be described in §XI.2.

3.6. A more subtle and interesting example is a real, complex, or quaternionic projective space. Given any field F , an n -dimensional projective space over F is defined to be the set of all 1-dimensional subspaces in an $(n + 1)$ -dimensional vector space over F . This definition is valid even if the field F is noncommutative (although then one should distinguish between right and left vector spaces over F). Since any $(n + 1)$ -dimensional vector space over F is isomorphic to the space F^{n+1} of all $(n + 1)$ -tuples of elements of F , we may as well restrict ourselves to consideration of F^{n+1} . Any point (x_1, \dots, x_{n+1}) of F^{n+1} different from $(0, \dots, 0)$ determines a unique 1-dimensional subspace, and hence a unique point of the corresponding projective space. Two such $(n + 1)$ -tuples, (x_1, \dots, x_{n+1}) and (y_1, \dots, y_{n+1}) determine the same point of projective space if and only if there exists a nonzero element λ of F such that $y_i = \lambda x_i$ for $1 \leq i \leq n + 1$. In books on projective geometry, such an $(n + 1)$ -tuple is referred to as a set of *homogeneous coordinates* for the corresponding point in projective space.

We will only be interested in the cases where F is the field of real numbers, complex numbers, or quaternions. In each of these cases the field F has a standard topology, and the vector space F^{n+1} is given the product topology. The corresponding projective space can be looked on as a quotient space of $F^{n+1} - \{0\}$, and it is customary to give it the quotient space topology. Alternatively, the projective space can be topologized as a quotient space of the unit sphere with center at the origin in F^{n+1} .

There is an obvious imbedding of F^n in F^{n+1} , defined by $(x_1, \dots, x_n) \rightarrow (x_1, \dots, x_n, 0)$. This leads to a corresponding imbedding of the $(n - 1)$ -dimensional projective space into the n -dimensional projective space over F . This kind of imbedding will define the skeletons of a CW-complex on these projective spaces. We will now discuss in more detail each of the cases:

Case 1: $F =$ real numbers. The n -dimensional real projective space, denoted by RP^n , is the set of all 1-dimensional subspaces of \mathbf{R}^{n+1} . It may be topologized as a quotient space of $\mathbf{R}^{n+1} - \{0\}$, or of the unit sphere, S^n . Each 1-dimensional subspace of \mathbf{R}^{n+1} intersects S^n in a pair of antipodal points. Hence S^n is a 2-sheeted covering space of RP^n (see Example V.8.2 on p. 137). The inclusions $\mathbf{R}^1 \subset \mathbf{R}^2 \subset \dots \subset \mathbf{R}^{n+1}$ give rise to corresponding inclusions of real projective spaces:

$$RP^0 \subset RP^1 \subset RP^2 \subset \dots \subset RP^n.$$

It is clear that RP^0 is a single point, and easy to verify that RP^1 is a circle. We

will take these subspaces as the skeletons of a CW-complex. We assert that RP^k is obtained from RP^{k-1} by the adjunction of a single cell of dimension k . Using homogeneous coordinates in RP^k , the characteristic map

$$f_k: E^k \rightarrow RP^k$$

is defined by the formula

$$f_k(x_1, \dots, x_k) = (x_1, \dots, x_k, \sqrt{1 - |x|^2}),$$

where $x = (x_1, \dots, x_n)$. We leave it to the reader to verify that f_k maps $E^k - S^{k-1}$ homeomorphically onto $RP^k - RP^{k-1}$, and S^{k-1} onto RP^{k-1} (but not homeomorphically).

Case 2: $F =$ complex numbers. The n -dimensional complex projective space, denoted by CP^n , is the set of all 1-dimensional subspaces of the complex vector space C^{n+1} . The inclusions

$$C^1 \subset C^2 \subset \dots \subset C^{n+1}$$

give rise to corresponding inclusions of complex projective spaces,

$$CP^0 \subset CP^1 \subset \dots \subset CP^n.$$

Once again, CP^0 is a single point, and it may be shown without too much difficulty that CP^1 is homeomorphic to S^2 . In this case, CP^k is obtained from CP^{k-1} by the adjunction of a single cell of dimension $2k$. The adjunction map

$$f_k: E^{2k} \rightarrow CP^k$$

is defined by the formula

$$f_k(z_1, \dots, z_k) = (z_1, \dots, z_k, \sqrt{1 - |z|^2}).$$

Here we are using the following notational conventions: $z = (z_1, \dots, z_k)$ is a point of $C^k = R^{2k}$. On the right-hand side of this formula we are using homogeneous coordinates in CP^k . The norm of z is defined by

$$|z| = (|z_1|^2 + |z_2|^2 + \dots + |z_k|^2)^{1/2}.$$

E^{2k} is the unit ball in $C^k = R^{2k}$. Once again, it can be verified that f_k maps S^{2k-1} onto CP^{k-1} , and $E^{2k} - S^{2k-1}$ homeomorphically onto $CP^k - CP^{k-1}$. Hence we can take CP^k as the $2k$ -skeleton of CP^n for $k = 0, 1, \dots, n$. The $2k + 1$ -dimensional skeleton is the same as the $2k$ dimensional skeleton. There are cells of dimensions $0, 2, 4, \dots, 2n$.

Case 3: $F =$ quaternions. This case is very similar to the preceding. The n -dimensional quaternionic projective space is denoted by QP^n . We have inclusions,

$$QP^0 \subset QP^1 \subset \dots \subset QP^n.$$

QP^0 is a single point and QP^1 is homeomorphic to S^4 . QP^k is obtained from QP^{k-1} by adjunction of a single cell of dimension $4k$. The formula for the

characteristic map is the same as in the two preceding cases, using quaternions in place of real or complex numbers. QP^n is a CW-complex having a single cell in each of the dimensions, $0, 4, 8, \dots, 4n$.

For further details about these projective spaces, the reader is referred to Bourbaki [1] or Brown [8].

Not every Hausdorff space admits a CW-complex structure. If it does admit such a structure, then usually it admits infinitely many different such structures (e.g., consider a finite regular graph as a CW-complex, and consider all its subdivisions).

Among the nice properties of a CW-complex, we list the following without proof:

- (i) A CW-complex is paracompact, and hence normal.
- (ii) A CW-complex is *locally contractible*, i.e., every point has a basic family of contractible neighborhoods.
- (iii) A compact subset of a CW-complex meets only a finite number of cells. A CW-complex is compact if and only if it is finite.
- (iv) A function f defined on a CW-complex is continuous if and only if the restriction of f to the closure \bar{e}^n of every n -cell is continuous ($n = 0, 1, 2, \dots$).

A subset A of a CW-complex is called a *subcomplex* if A is a union of cells of X , and if for any cell e^n ,

$$e^n \subset A \Rightarrow \bar{e}^n \subset A.$$

If this is the case, it may be shown that the sets

$$A^n = A \cap X^n, \quad n = 0, 1, 2, \dots,$$

define a CW-complex structure on A .

For example, the skeletons X^n are subcomplexes.

Definition 3.2. A continuous map of $f: X \rightarrow Y$ of one CW-complex into another is called *cellular* if $f(X^n) \subset Y^n$ for $n = 0, 1, 2, \dots$ (here X^n and Y^n denote the n -skeletons of X and Y).

In [10] J. H. C. Whitehead proves that any continuous map $X \rightarrow Y$ is homotopic to a cellular map.

§4. The Homology Groups of a CW-Complex

The purpose of this section is to apply the results of §2 to CW-complexes in a systematic way.

Let $K = \{K^n | n = 0, 1, 2, \dots\}$ denote a structure of CW-complex on the topological space X (each K^n is a closed subset of X). We will define $K^n = \emptyset$

for $n < 0$. Since K^n is obtained from K^{n-1} by the adjunction of n -cells (by definition), we can apply the results of Theorem 2.1 to conclude that

$$H_q(K^n, K^{n-1}) = 0$$

for $q \neq n$ and that $H_n(K^n, K^{n-1})$ is a free abelian group with basis in 1-1 correspondence with the n -cells of K .

Lemma 4.1. $H_q(K^n) = 0$ for all $q > n$.

The proof is by induction on n . For $n = 0$, the lemma is trivial, since K^0 is a discrete space (by definition). The inductive step is proved by using the homology sequence of the pair (K^n, K^{n-1}) .

We will now associate with the CW-complex K certain “chain groups” $C_n(K)$, $n = 0, 1, 2, \dots$, and then we will prove that the n th homology group obtained from these chain groups is naturally isomorphic to $H_n(X)$. The definitions are as follows:

$$C_n(K) = H_n(K^n, K^{n-1}),$$

and

$$d_n : C_n(K) \rightarrow C_{n-1}(K)$$

is defined to be the composition of homomorphisms,

$$H_n(K^n, K^{n-1}) \xrightarrow{\partial_*} H_{n-1}(K^{n-1}) \xrightarrow{j_{n-1}} H_{n-1}(K^{n-1}, K^{n-2}),$$

where ∂_* is the boundary operator of the pair (K^n, K^{n-1}) and j_{n-1} is the homomorphism induced by the inclusion map. Of course, one must verify that $d_{n-1}d_n = 0$, but this is easy. We will find it convenient to denote the n -dimensional groups of cycles, bounding cycles, and homology classes derived from these chain groups by the notations

$$Z_n(K), \quad B_n(K), \quad \text{and} \quad H_n(K),$$

respectively, here $Z_n(K) = \text{kernel } d_n$, $B_n(K) = \text{image } d_{n+1}$, and $H_n(K) = Z_n(K)/B_n(K)$.

For the statement of the main theorem, consider the following diagram:

$$H_n(X) \xleftarrow{k_n} H_n(K^n) \xrightarrow{j_n} H_n(K^n, K^{n-1}) = C_n(K).$$

Here j_n and k_n are homomorphisms induced by inclusion maps.

Theorem 4.2. *In the above diagram:*

k_n is an epimorphism.

j_n is a monomorphism.

image $j_n = Z_n(K)$.

kernel $k_n = j_n^{-1}(B_n(K))$.

Then $j_n \circ k_n^{-1}$ defines an isomorphism

$$\theta_n : H_n(X) \rightarrow H_n(K).$$

is an epimorphism for all n . In view of the commutativity of the diagram

$$\begin{array}{ccc} H_n(K^n) & \xrightarrow{i_{n+1}} & J_n(K^{n+1}) \\ & \searrow k_n & \swarrow k_{n+1} \\ & & H_n(X) \end{array}$$

and the fact that k_{n+1} is an isomorphism, it follows that k_n is onto, and $\text{kernel } k_n = \text{kernel } i_{n+1}$. Thus, we may replace exact sequence (9.4.1) by the following:

$$0 \rightarrow H_n(K^n) \xrightarrow{j_n} H_n(K^n, K^{n-1}) \xrightarrow{\partial_*} H_{n-1}(K^{n-1}) \xrightarrow{k_{n-1}} H_{n-1}(X) \rightarrow 0. \quad (9.4.3)$$

Since $d_n = j_{n-1} \partial_*$, and j_{n-1} is a monomorphism, we see that

$$\begin{aligned} Z_n(K) &= \text{kernel } d_n = \text{kernel } \partial_* \\ &= \text{image } j_n. \end{aligned}$$

Next, we see that

$$\begin{aligned} \text{kernel } k_{n-1} &= \text{image } \partial_* \\ &= j_{n-1}^{-1}(\text{image } j_{n-1} \partial_*) \\ &= j_{n-1}^{-1}(\text{image } d_n) \\ &= j_{n-1}^{-1}(B_{n-1}(K)) \end{aligned}$$

as required.

This completes the proof of Theorem 4.2.

Q.E.D.

We will now consider some applications of this theorem:

(1) Suppose X is a CW-complex which is n -dimensional. Then

$$H_q(X) = 0 \quad \text{for } q > n.$$

(2) Suppose X is a CW-complex with only a finite number of n -dimensional cells. Then $H_n(X)$ is a finitely generated abelian group (hence it is a direct sum of cyclic groups).

(3) Suppose X is a CW-complex with no n -dimensional cells. Then $H_n(X) = 0$.

(4) *The Euler characteristic.* Let $K = \{K^n\}$ be a structure of finite CW-complex on the space X (hence X is compact). Denote the number of n -cells of K by α_n . The *Euler characteristic* of K is defined to be the integer

$$\chi(K) = \sum_{n \geq 0} (-1)^n \alpha_n.$$

We will now outline a proof that $\chi(K)$ is actually a homotopy type invariant of the space X ; it does not depend on K .

Define a subset of an abelian group to be *linearly independent* if it satisfies the usual condition with *integer* coefficients. Then define the *rank* of an abelian

group to be the cardinal number of a maximal linearly independent subset. Earlier, we defined the rank of a free abelian group to be the cardinal number of a basis; it is an exercise in matrix theory to prove that the two definitions are equivalent in the case of free abelian groups.

For any abelian group A , let $r(A)$ denote the rank of A . One can now prove the following facts about the rank of abelian groups:

- (a) If B is a subgroup or quotient group of A , then $r(B) \leq r(A)$. Hence any finitely generated abelian group has finite rank.
- (b) Let $0 \rightarrow A \rightarrow B \rightarrow C \rightarrow 0$ be a short exact sequence abelian groups with B of finite rank. Then

$$r(B) = r(A) + r(C).$$

The proofs are left to the reader.

The proof of invariance of the Euler characteristic of a finite CW-complex depends on the following lemma:

Lemma 4.3. *Let K be a finite CW-complex on the space X . Then*

$$\sum_n (-1)^n r(C_n(K)) = \sum_n (-1)^n r(H_n(K)).$$

We leave the proof, which depends on statement (a) and (b), to the reader. The following important theorem is an immediate corollary.

Theorem 4.4. *Let $K = \{K^n\}$ be a finite CW-complex on the space X . Then the Euler characteristic satisfies the following equation:*

$$\chi(K) = \sum_n (-1)^n r(H_n(X)).$$

Hence $\chi(K)$ is independent of the choice of the CW-complex K on the space X .

(5) *The homology groups of n -dimensional projective space.* Using the CW-complexes on CP^n and QP^n described in the previous section, the following results are immediate:

$$H_q(CP^n) = \begin{cases} \mathbf{Z} & \text{for } q \text{ even and } 0 \leq q \leq 2n \\ 0 & \text{otherwise,} \end{cases}$$

$$H_q(QP^n) = \begin{cases} \mathbf{Z} & \text{for } q \equiv 0 \pmod{4} \text{ and } 0 \leq q \leq 4n \\ 0 & \text{otherwise.} \end{cases}$$

On the other hand, the methods we have developed do not suffice to determine the homology groups of RP^n . All one can prove using these methods is that $H_q(RP^n)$ is a cyclic group for $0 \leq q \leq n$ and is 0 otherwise [of course, $H_0(RP^n)$ is infinite cyclic].

Next, we will discuss the homomorphism induced by a cellular map of one

CW-complex into another. Let $K = \{K^n\}$ be a CW-complex on the space X , and let $L = \{L^n\}$ be a CW-complex on the space Y , and let $f: X \rightarrow Y$ be a cellular map, i.e., $f(K^n) \subset L^n$ for all n . Then for each integer n , f induces a homomorphism of the homology sequence of the pair (K^n, K^{n-1}) into the homology sequence of the pair (L^n, L^{n-1}) . Thus, we have the following commutative diagram:

$$\begin{array}{ccccccccccc}
 0 & \longrightarrow & H_n(K^n) & \xrightarrow{j_n} & H_n(K^n, K^{n-1}) & \xrightarrow{\partial_*} & H_{n-1}(K^{n-1}) & \xrightarrow{i_n} & H_{n-1}(K^n) & \longrightarrow & 0 \\
 & & \downarrow f_n & & \downarrow \phi_n & & \downarrow f_{n-1} & & \downarrow f_n & & \\
 0 & \longrightarrow & H_n(L^n) & \xrightarrow{j_n} & H_n(L^n, L^{n-1}) & \xrightarrow{\partial_*} & H_{n-1}(L^{n-1}) & \xrightarrow{i_n} & H_{n-1}(L^n) & \longrightarrow & 0
 \end{array}$$

Here $f_n: K^n \rightarrow L^n$ is the map induced by f , as is $\phi_n: (K^n, K^{n-1}) \rightarrow (L^n, L^{n-1})$. In view of the definition of the boundary operator $d_n: C_n(K) \rightarrow C_{n-1}(K)$ above, it follows that the following diagram is commutative for all n :

$$\begin{array}{ccc}
 C_n(K) & \xrightarrow{\phi_n} & C_n(L) \\
 \downarrow d_n & & \downarrow d_n \\
 C_{n-1}(K) & \xrightarrow{\phi_{n-1}} & C_{n-1}(L)
 \end{array}$$

Hence by exactly the same reasoning used in §VII.3, we conclude that the collection of homomorphisms $\{\phi_n\}$ induce homomorphisms

$$\phi_*: H_n(K) \rightarrow H_n(L), \quad n = 0, 1, 2, \dots$$

Theorem 4.5. *The induced homomorphisms $f_*: H_n(X) \rightarrow H_n(Y)$ and $\phi_*: H_n(K) \rightarrow H_n(L)$ correspond under the isomorphisms θ_n of Theorem 4.2., i.e., the following diagram is commutative for all n :*

$$\begin{array}{ccc}
 H_n(X) & \xrightarrow{\theta_n} & H_n(K) \\
 \downarrow f_* & & \downarrow \phi_* \\
 H_n(Y) & \xrightarrow{\theta_n} & H_n(L)
 \end{array}$$

PROOF. This follows immediately from the fact that the following diagram is commutative for all n , together with the definition of θ_n contained in Theorem 4.2:

$$\begin{array}{ccccc}
 H_n(X) & \xrightarrow{k_n} & H_n(K^n) & \xrightarrow{j_n} & H_n(K^n, K^{n-1}) \\
 \downarrow f & & \downarrow f_n & & \downarrow \phi_n \\
 H_n(Y) & \xrightarrow{k_n} & H_n(L^n) & \xrightarrow{j_n} & H_n(L^n, L^{n-1})
 \end{array}$$

We will conclude this section with a discussion of the effective computability of the various concepts introduced in this section. First of all, the groups $C_n(K)$, $n = 0, 1, 2, \dots$, are free groups with basis in 1–1 correspondence with the set of n -cells of K , hence they may be considered to be well determined. To compute the homology groups $H_n(K) \approx H_n(X)$, we must determine the homomorphisms

$$d_n : C_n(K) \rightarrow C_{n-1}(K), \quad n = 0, 1, 2, \dots$$

In general, these homomorphisms will depend on the choice of the characteristic maps by which the various cells are attached, and there seems to be no universal, simple, method for their determination. The following simple example illustrates this point. Let X be a torus and Y a Klein bottle. We may choose CW-complexes K and L on X and Y , respectively, each of which has one vertex, two 1-cells, and one 2-cell. Thus $C_n(K) \approx C_n(L)$ for all n . However, since $H_n(K) \not\approx H_n(L)$ for $n = 1$, or 2 , it follows that the boundary homomorphisms d_n for K and L must be essentially different (compare §VIII.4). The reason, of course, lies in the fact that the 2-cell is attached by different maps in the two cases.

The situation is even worse as regards the computation of the homomorphisms $\varphi_n : C_n(K) \rightarrow C_n(L)$ mentioned earlier. Here an example is furnished by the case $X = Y = S^n$, the n -sphere. We proved earlier (cf. Exercise VIII.3.2) that there exist continuous maps $S^n \rightarrow S^n$ of every possible degree. If we take $K = L$ to be a CW-complex with one vertex and one n -cell, then a map $S^n \rightarrow S^n$ will be cellular if and only if the vertex is mapped onto the vertex; and this can always be arranged by an appropriate homotopic deformation of any given map. Thus it is clear that in such cases Theorem 4.5 is of no help in determining the homomorphism induced by a continuous map.

One of our objectives will be to introduce a more restricted class of CW-complexes and cellular maps such that the boundary operator and the induced homomorphism are actually computable.

§5. Incidence Numbers and Orientations of Cells

This section is devoted to some material of a more or less technical nature which will be used in the computation of homology groups of CW-complexes.

As in the preceding section, let $K = \{K^n\}$ be a CW-complex on the space X . For each n -cell, e_λ^n , there is a characteristic map,

$$f_\lambda : (E^n, S^{n-1}) \rightarrow (K^n, K^{n-1})$$

and according to Theorem 2.1 the induced homomorphism on the n -dimensional relative homology groups is a monomorphism, and $H_n(K^n, K^{n-1})$

is the direct sum of the image subgroups. The characteristic map f_λ corresponding to the cell e_λ^n is by no means unique, and it is conceivable that this direct sum decomposition of the group $H_n(K^n, K^{n-1})$ depends on the choices of the characteristic maps. Before proceeding further, it is important to point out that this is not the case; the direct sum decomposition of $H_n(K^n, K^{n-1})$ is *canonical*, and independent of the choices of the characteristic maps. This may be proved as follows. For any n -cell e_λ^n , $n > 0$, let

$$\dot{e}_\lambda^n = \bar{e}_\lambda^n - e_\lambda^n.$$

We will call \dot{e}_λ^n the *boundary* of e_λ^n , even though it need not coincide with the boundary in the sense of point set topology. We can factor the characteristic map f_λ through the pair $(\bar{e}_\lambda^n, \dot{e}_\lambda^n)$, as follows:

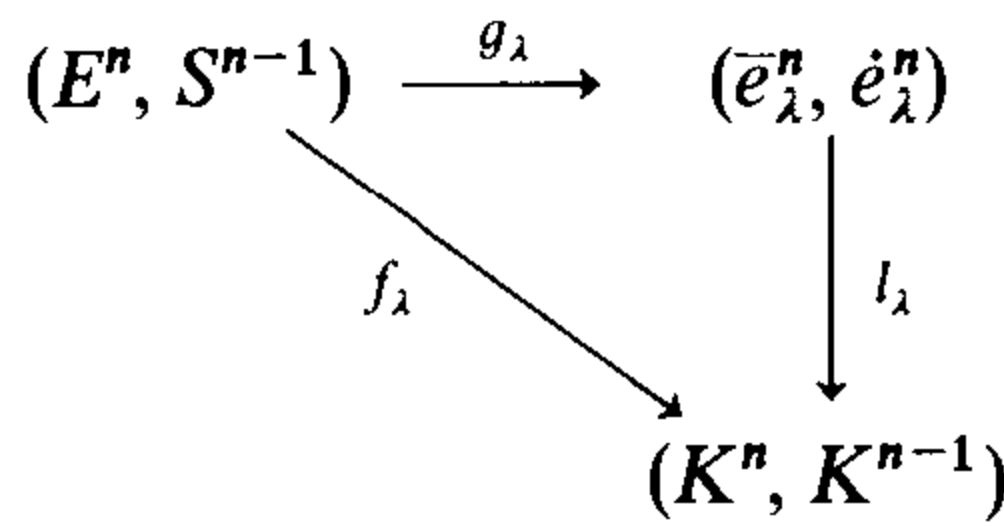

Here l_λ is an inclusion map. Passing to homology, we obtain the following commutative diagram:

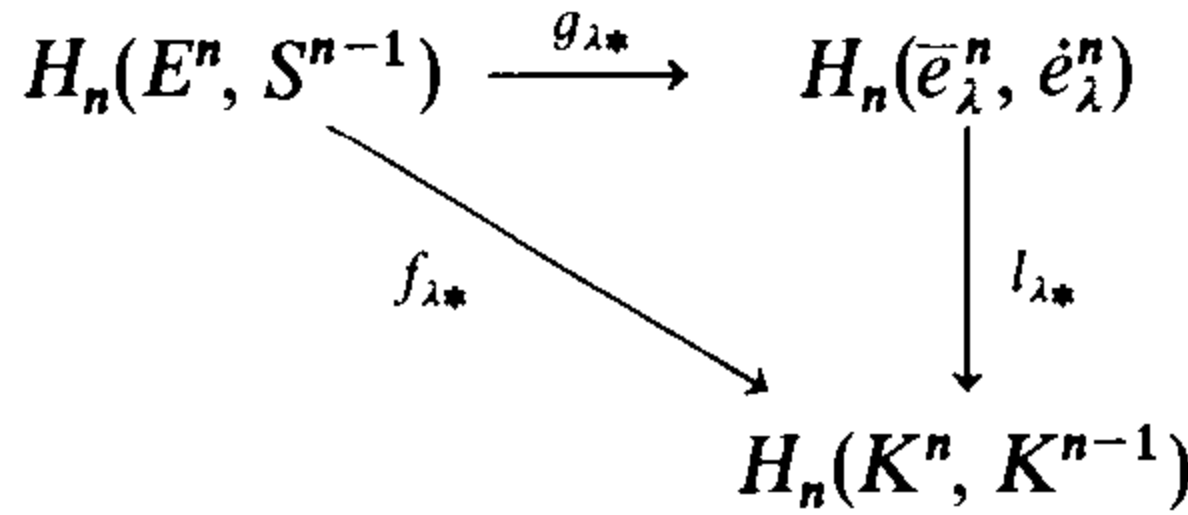

We can apply Theorem 2.1 with $(X^*, X) = (\bar{e}_\lambda^n, \dot{e}_\lambda^n)$ to conclude that $g_{\lambda*}$ is an isomorphism. Hence,

$$\text{image } f_{\lambda*} = \text{image } l_{\lambda*}$$

and, therefore, image $f_{\lambda*}$ is independent of the choice of the characteristic map f_λ , as was to be proved. Note that this also proves that $l_{\lambda*}$ is a monomorphism, and $H_n(K^n, K^{n-1})$ is the direct sum of the images for all $\lambda \in \Lambda$.

Since the group $H_n(\bar{e}_\lambda^n, \dot{e}_\lambda^n)$ is infinite cyclic for $n > 0$, there are two ways to choose a generator and the choices are negatives of each other. We will call a generator of the group $H_n(\bar{e}_\lambda^n, \dot{e}_\lambda^n)$ an *orientation* of the cell e_λ^n .

Assume we have chosen an orientation $a_\lambda^n \in H_n(\bar{e}_\lambda^n, \dot{e}_\lambda^n)$ for each n -cell e_λ^n ; let

$$b_\lambda^n = l_{\lambda*}(a_\lambda^n) \in C_n(K).$$

Then the set $\{b_\lambda^n\}$ is a basis for the chain group $C_n(K)$.

The foregoing remarks are only valid if $n > 0$; the case $n = 0$ must be modified, as follows. By definition, $C_0(K) = H_0(K^0)$, and

$$H_0(K^0) = \sum_{\lambda \in \Lambda} H_0(e_\lambda^0),$$

where $\{e_\lambda^0 \mid \lambda \in \Lambda\}$ denotes the set of 0-cells (or vertices) of K . For each λ , the augmentation homomorphism

$$\varepsilon_* : H_0(e_\lambda^0) \rightarrow Z$$

is a *natural* isomorphism. We will *always* choose $a_\lambda^0 \in H_0(e_\lambda^0)$ to be the unique element such that $\varepsilon_*(a_\lambda^0) = 1$, and let $b_\lambda^0 \in H_0(K^0) = C_0(K)$ be the element corresponding to a_λ^0 . Thus, $\{b_\lambda^0 \mid \lambda \in \Lambda_0\}$ is a basis for $C_0(K)$.

The distinction between the cases $n = 0$ and $n > 0$ may be summarized as follows: For $n > 0$, an n -cell has two orientations, and there is no reason to prefer one orientation over the other. On the other hand, a 0-cell consists of a single point, and the question of choice of orientation does not arise in this case.

Assume, then, that the case $\{b_\lambda^n \mid \lambda \in \Lambda_n\}$ have been chosen for the chain groups $C_n(K)$ for $n = 0, 1, 2, \dots$, as described above. The boundary homomorphisms

$$d_n : C_n(K) \rightarrow C_{n-1}(K), \quad n = 1, 2, 3, \dots,$$

are completely determined by the value of d_n of the basis elements; and we may uniquely express $d_n(b_\lambda^n)$ as a linear combination of the b_μ^{n-1} 's. It is customary to use the following notation for this purpose:

$$d_n(b_\lambda^n) = \sum_\mu [b_\lambda^n : b_\mu^{n-1}] b_\mu^{n-1}.$$

The integral coefficient $[b_\lambda^n : b_\mu^{n-1}]$ is called the *incidence number* of the cells e_λ^n and e_μ^{n-1} (with respect to the chosen orientations). Obviously, the homomorphism d_n is completely determined by the incidence numbers, and vice versa. The most important properties of the incidence numbers are summarized in the following two lemmas.

Lemma 5.1. *The incidence numbers of a CW-complex have the following properties:*

- (a) For any n -cell e_λ^n , $[b_\lambda^n : b_\mu^{n-1}] = 0$ for all but a finite number of $(n-1)$ -cells e_μ^{n-1} .
- (b) For any n -cell e_λ^n and $(n-2)$ -cell e_ν^{n-2} ,

$$\sum_\mu [b_\lambda^n : b_\mu^{n-1}] [b_\mu^{n-1} : b_\nu^{n-2}] = 0.$$

- (c) For any 1-cell e_λ^1 , $\sum_\mu [b_\lambda^1 : b_\mu^0] = 0$.

- (d) $[-b_\lambda^n : b_\mu^{n-1}] = [b_\lambda^n : -b_\mu^{n-1}] = -[b_\lambda^n : b_\mu^{n-1}]$.

PROOF. The proof of (a) is a direct consequence of the definition of incidence numbers, and the proof of (b) follows from the relation $d_{n-1}d_n = 0$. To prove (c), recall that $C_1(K) = H_1(K^1, K^0)$, $C_0(K) = H_0(K^0, K^{-1}) = H_0(K^0)$, and $d_1 : C_1(K) \rightarrow C_0(K)$ is the homomorphism

$$\partial_* : H_1(K^1, K^0) \rightarrow H_0(K^0)$$

in the homology sequence of the pair (K^1, K^0) . Now consider the following diagram, which is commutative:

$$\begin{array}{ccc}
 & & \tilde{H}_0(K_0) \\
 & \nearrow \tilde{\partial}_* & \downarrow \xi \\
 H_1(K^1, K^0) & \xrightarrow{\partial_*} & H_0(K^0) \\
 & & \downarrow \varepsilon_* \\
 & & Z
 \end{array}$$

The vertical line is exact by Proposition VII.2.4, hence $\varepsilon_* \xi = 0$. Therefore,

$$\varepsilon_* \partial_* = \varepsilon_* \xi \tilde{\partial}_* = 0.$$

Hence we obtain

$$\begin{aligned}
 0 &= \varepsilon_* \partial_* (b_\lambda^1) = \varepsilon_* d_1(b_\lambda^1) \\
 &= \varepsilon_* \sum_\mu [b_\lambda^1 : b_\mu^0] b_\mu^0 = \sum_\mu [b_\lambda^1 : b_\mu^0] \varepsilon_*(b_\mu^0) \\
 &= \sum_\mu [b_\lambda^1 : b_\mu^0]
 \end{aligned}$$

since b_μ^0 was chosen so that $\varepsilon_*(b_\mu^0) = 1$.

The proof of (d) is trivial.

Q.E.D.

Lemma 5.2. *If the cell e_μ^{n-1} is not contained in the closure of the cell e_λ^n , then $[b_\lambda^n : b_\mu^{n-1}] = 0$.*

PROOF. Earlier in this section, it was pointed out that the canonical direct sum decomposition of the group $C_n(K) = H_n(K^n, K^{n-1})$ is determined by the monomorphisms

$$l_{\lambda*} : H_n(\bar{e}_\lambda^n, \dot{e}_\lambda^n) \rightarrow H_n(K^n, K^{n-1})$$

for all n -cells e_λ^n of K . Corresponding to this direct sum decomposition, there are projections of $C_n(K)$ onto each of the summands. We assert that these projections may be described in terms of the following commutative diagram:

$$\begin{array}{ccc}
 H_n(\bar{e}_\lambda^n, \dot{e}_\lambda^n) & \xrightarrow{l_{\lambda*}} & H_n(K^n, K^{n-1}) \\
 \downarrow l_{\lambda*} & & \uparrow m_{\lambda*} \\
 H_n(K^n, K^n - e_\lambda^n) & &
 \end{array}$$

Here l'_λ and m_λ are inclusion maps. We assert that $l'_{\lambda*}$ is an isomorphism and $m_{\lambda*}$ composed with the inverse of $l'_{\lambda*}$ gives the projection of $C_n(K)$ onto the direct summand corresponding to the cell e_λ^n . The proof that $l'_{\lambda*}$ is an isomorphism is based on Theorem 2.1, and is exactly the same as the proof that $l_{\lambda*}$ is a monomorphism whose image is a direct summand. To prove the assertion about $m_{\lambda*}$, one must prove that if $e_\lambda^n \neq e_\mu^n$, then $m_{\mu*}l_{\lambda*} = 0$; this is an easy consequence of Lemma 5.3 below.

In view of these facts, and the definition of incidence numbers, it is clear that in order to prove $[b_\lambda^n, b_\mu^{n-1}] = 0$, we must prove that the following composition of homomorphisms is zero:

$$\begin{array}{ccccccc}
 H_n(\bar{e}_\lambda^n, \dot{e}_\lambda^n) & \xrightarrow{l_{\lambda*}} & H_n(K^n, K^{n-1}) & \xrightarrow{\partial_*} & H_{n-1}(K^{n-1}) & \xrightarrow{j_{n-1}} & H_{n-1}(K^{n-1}, K^{n-2}) \\
 & & & & & & \downarrow m_{\mu*} \\
 & & & & & & H_{n-1}(K^{n-1}, K^{n-1} - e_\mu^{n-1})
 \end{array}$$

We can imbed this sequence of homomorphisms in the following commutative diagram:

$$\begin{array}{ccccccc}
 H_n(K^n, K^{n-1}) & \xrightarrow{\partial_*} & H_{n-1}(K^{n-1}) & \xrightarrow{j_{n-1}} & H_{n-1}(K^{n-1}, K^{n-2}) \\
 \uparrow l_{\lambda*} & & \uparrow & & \downarrow m_{\mu*} \\
 H_n(\bar{e}_\lambda^n, \dot{e}_\lambda^n) & \xrightarrow{\partial'} & H_{n-1}(\dot{e}_\lambda^n) & \xrightarrow{j_*} & H_{n-1}(K^{n-1}, K^{n-1} - e_\mu^{n-1})
 \end{array}$$

By commutativity of the squares in this diagram, we see that we must prove

$$j_* \partial' = 0.$$

Since e_μ^{n-1} is not contained in \bar{e}_λ^n , the inclusion map $j: \dot{e}_\lambda^n \rightarrow (K^{n-1}, K^{n-1} - e_\mu^{n-1})$ is homotopic to a map of \dot{e}_λ^n into $K^{n-1} - e_\mu^{n-1}$ (to see this, choose a point $x_0 \in e_\mu^{n-1}$ such that $x_0 \notin \bar{e}_\lambda^n$; the required homotopy of the map j is defined by means of a "radial projection" outward from the point x_0 to the boundary of the cell e_μ^{n-1}). It follows from Lemma 5.3 below that $j_* = 0$, and the proof is complete. Q.E.D.

Lemma 5.3. *Let $f: (X, A) \rightarrow (Y, B)$ be a map of pairs which is homotopic to a map $g: (X, A) \rightarrow (Y, B)$ such that $g(X) \subset B$. Then the induced homomorphism*

$$f_*: H_n(X, A) \rightarrow H_n(Y, B)$$

is zero for all n .

PROOF. By the homotopy property, $f_* = g_*$; hence, we must prove that $g_* = 0$. The hypotheses imply that g can be factored, as follows:

$$(X, A) \xrightarrow{g'} (B, B) \xrightarrow{i} (Y, B).$$

Passing to homology, we have

$$H_n(X, A) \xrightarrow{g'_*} H_n(B, B) \xrightarrow{i_*} H_n(Y, B).$$

Since $H_n(B, B) = 0$ for all n , the result follows.

§6. Regular CW-Complexes

We will now introduce a special category of CW-complexes which have the property that their homology groups are effectively computable (at least in case the complex is finite).

Definition 6.1. A CW-complex is *regular* if for each cell e^n , $n > 0$, there exists a characteristic map $f : E^n \rightarrow \bar{e}^n$ which is a homeomorphism.

We recall that previously we have only required that the characteristic map be a homeomorphism of U^n onto e^n , and map S^{n-1} into the $(n - 1)$ -skeleton. We are now requiring in addition that the characteristic map be a homeomorphism of S^{n-1} into K^{n-1} .

To clarify the definition, we present in Figure 9.1 an example of a CW-complex on the closed 2-dimensional disc which is *not* regular. There are three vertices, three edges, and one 2-cell:

We now list three basic geometric properties of regular CW-complexes:

(1) If $m < n$ and e^m and e^n are cells such that $e^m \cap \bar{e}^n \neq \emptyset$, then $e^m \subset \bar{e}^n$.

(2) For any n -cell e^n , $n \geq 0$, \bar{e}^n and \dot{e}^n are the underlying spaces of sub-complexes. Also, \dot{e}^n is the union of closures of $(n - 1)$ -cells.

Before stating the third property, we need a definition. We say e^m is a *face* of e^n if $e^m \subset \bar{e}^n$, and denote this by $e^m \leq e^n$. Clearly, every cell is a face of itself; we say e^m is a *proper face* of e^n if it is a face of e^n , and $e^m \neq e^n$ (NOTATION: $e^m < e^n$). This definition makes sense in a regular cell complex mainly because of property (1).

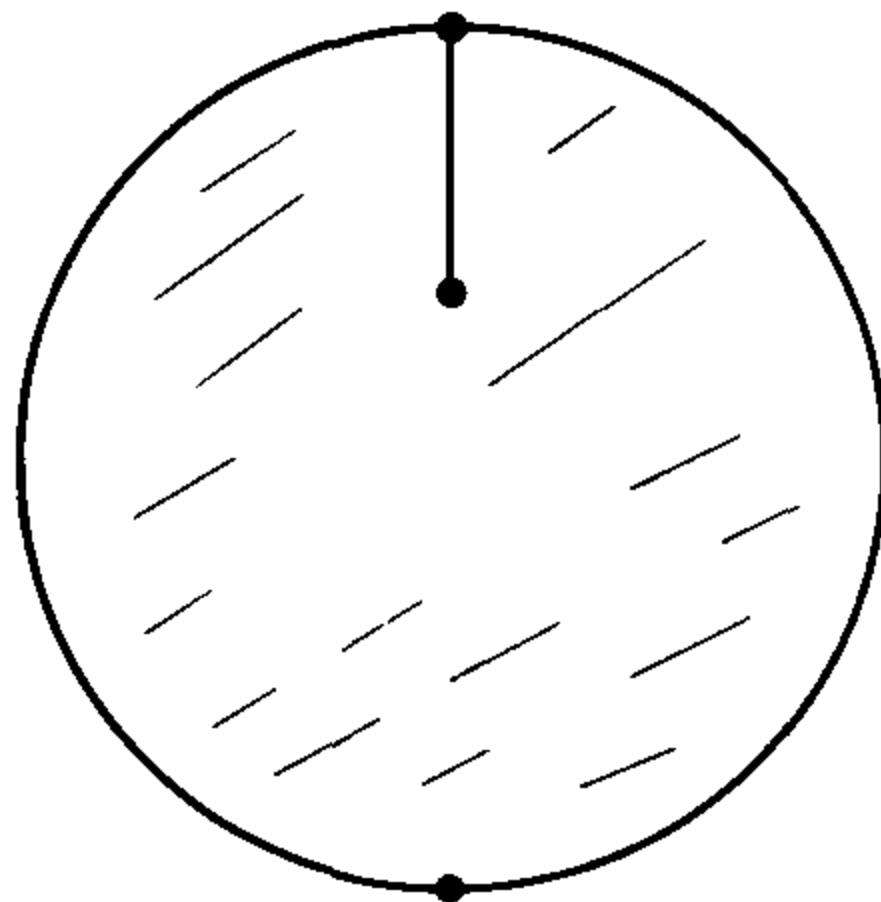

FIGURE 9.1

(3) Let e^n and e^{n+2} be cells of a regular cell complex such that e^n is a face of e^{n+2} . Then there are exactly two $(n + 1)$ -cells e^{n+1} such that $e^n < e^{n+1} < e^{n+2}$.

It should be emphasized that (1), (2), and (3) need not be true for nonregular CW-complexes. The proofs depend on Brouwer's theorem on invariance of domain, Corollary VIII.6.7.

The proofs of (1), (2), and (3) are given by Cooke and Finney [2] or Massey [7]. We will not reproduce these proofs here. Actually, in any specific case it will be clear that these properties hold.

§7. Determination of Incidence Numbers for a Regular Cell Complex

Let K be a *regular* cell complex on the space X . We will denote the n -cells of K by the symbol e_λ^n , where the index λ ranges over a certain set Λ_n , $n = 0, 1, 2, \dots$. We assume orientations b_λ^n have been chosen for each cell e_λ^n as described in §5.

Lemma 7.1. *The incidence numbers $[b_\lambda^n : b_\mu^{n-1}]$ in a regular cell complex K satisfy the following four conditions:*

- (1) *If e_μ^{n-1} is not a face of e_λ^n , then $[b_\lambda^n : b_\mu^{n-1}] = 0$.*
- (2) *If e_μ^{n-1} is a face of e_λ^n , then $[b_\lambda^n : b_\mu^{n-1}] = \pm 1$.*
- (3) *If e_μ^0 and e_ν^0 are the two vertices which are faces of the 1-cell e_λ^1 , then*

$$[b_\lambda^1 : b_\mu^0] + [b_\lambda^1 : b_\nu^0] = 0.$$

- (4) *Let e_λ^n and e_ρ^{n-2} be cells such that $e_\rho^{n-2} < e_\lambda^n$; let e_μ^{n-1} and e_ν^{n-1} denote the unique $(n - 1)$ -cells e^{n-1} such that $e_\rho^{n-2} < e^{n-1} < e_\lambda^n$. Then*

$$[b_\lambda^n : b_\mu^{n-1}][b_\mu^{n-1} : b_\rho^{n-2}] + [b_\lambda^n : b_\nu^{n-1}][b_\nu^{n-1} : b_\rho^{n-2}] = 0.$$

PROOF. Condition (1) is a consequence of Lemma 5.2 and the definition of the term face.

In order to prove statement (2), we will make use of statement (2) of §6. According to this statement, \bar{e}_λ^n is a subcomplex of K which contains the cell e_μ^{n-1} , and it is easy to see that it does not matter whether we compute the incidence number $[b_\lambda^n : b_\mu^{n-1}]$ relative to the subcomplex \bar{e}_λ^n or to the whole complex K . Let $L = \{L^q\}$ denote this subcomplex on the space \bar{e}_λ^n . Then $L^n = \bar{e}_\lambda^n$ is a closed n -dimensional ball, and $L^{n-1} = \dot{e}_\lambda^n$ is an $(n - 1)$ -sphere. We will use the method of proof of Lemma 5.2 to prove the present lemma. Thus, we see that in the commutative diagram

$$\begin{array}{ccccc}
 H_n(L^n, L^{n-1}) & \xrightarrow{\partial_*} & \tilde{H}_{n-1}(L^{n-1}) & \xrightarrow{j_{n-1}} & H_{n-1}(L^{n-1}, L^{n-2}) \\
 & & \searrow k_* & & \downarrow m_{\mu*} \\
 & & & & H_{n-1}(L^{n-1}, L^{n-1} - e_\mu^{n-1})
 \end{array}$$

we must prove that $k_* \partial_*$ is an isomorphism. We will prove this by proving that both ∂_* and k_* are isomorphisms.

To prove that ∂_* is an isomorphism, one considers the homology sequence of the pair (L^n, L^{n-1}) . Since $L^n = \bar{e}_\lambda^n$ is contractible, $\tilde{H}_q(L^n) = 0$, and the desired result follows.

To prove that k_* is an isomorphism, one considers the homology sequence of the pair $(L^{n-1}, L^{n-1} - e_\mu^{n-1})$; k_* is one of the homomorphisms in this exact sequence. We will prove that $L^{n-1} - e_\mu^{n-1}$ is contractible, from which it will follow that

$$\tilde{H}_q(L^{n-1} - e_\mu^{n-1}) = 0$$

for all q , and hence that k_* is an isomorphism. To prove that $L^{n-1} - e_\mu^{n-1}$ is contractible, recall that L^{n-1} is an $(n - 1)$ -sphere. Let x be a point of e_μ^{n-1} ; then $L^{n-1} - e_\mu^{n-1}$ is obviously a deformation retract of $L^{n-1} - \{x\}$; and $L^{n-1} - \{x\}$ is homeomorphic to R^{n-1} , hence contractible. Therefore, $L^{n-1} - e_\mu^{n-1}$ is also contractible.

Statement (3) is a consequence of part (c) of Lemma 5.1 and statement (1), together with the obvious fact that any 1-cell in a regular CW-complex has exactly two vertices which are faces.

Statement (4) follows from part (b) of Lemma 5.1, statement (1), and statement (3) of §6. Q.E.D.

Our main theorem now asserts that the four conditions of the lemma just proved completely characterize the incidence numbers of a regular CW-complex.

Theorem 7.2. *Let K be a regular CW-complex on the topological space X . For each pair $(e_\lambda^n, e_\mu^{n-1})$ consisting of an n -cell and an $(n - 1)$ -cell of K , let there be given an integer $\alpha_{\lambda\mu}^n = 0$ or ± 1 such that the following four conditions hold:*

- (1) *If e_μ^{n-1} is not a face of e_λ^n , then $\alpha_{\lambda\mu}^n = 0$.*
- (2) *If e_μ^{n-1} is a face of e_λ^n , then $\alpha_{\lambda\mu}^n = \pm 1$.*
- (3) *If e_μ^0 and e_ν^0 are the two vertices of the 1-cell e_λ^1 , then*

$$\alpha_{\lambda\mu}^1 + \alpha_{\lambda\nu}^1 = 0.$$

- (4) *Let e_λ^n and e_ρ^{n-2} be cells of K such that $e_\rho^{n-2} < e_\lambda^n$; let e_μ^{n-1} and e_ν^{n-1} denote the unique $(n - 1)$ -cells e^{n-1} such that $e_\rho^{n-2} < e^{n-1} < e_\lambda^n$.*

Then

$$\alpha_{\lambda\mu}^n \alpha_{\mu\rho}^{n-1} + \alpha_{\lambda\nu}^n \alpha_{\nu\rho}^{n-1} = 0.$$

Under these assumptions, it is possible to choose an orientation b_λ^n for each cell e_λ^n in one and only one way such that

$$[b_\lambda^n : b_\mu^{n-1}] = \alpha_{\lambda\mu}^n$$

for all pairs $(e_\lambda^n, e_\mu^{n-1})$.

PROOF. We will prove the existence of the required orientation b_λ^n on the cell e_λ^n by induction on n . For $n = 0$ there is no choice: a 0-cell has a unique orientation, which we denote by b_λ^0 .

Next, let e_λ^1 be a 1-cell, and let e_μ^0 and e_ν^0 be the two vertices which are faces of it. It is clear that one of the two possible orientations of e_λ^1 , which we will denote by b_λ^1 , satisfies the equation

$$[b_\lambda^1 : b_\mu^0] = \alpha_{\lambda\mu}^1.$$

Then since

$$\alpha_{\lambda\mu}^1 + \alpha_{\lambda\nu}^1 = 0,$$

$$[b_\lambda^1 : b_\mu^0] + [b_\lambda^1 : b_\nu^0] = 0,$$

it follows that

$$[b_\lambda^1 : b_\nu^0] = \alpha_{\lambda\nu}^1,$$

as required.

Now we make the inductive step. Assume that an orientation b_λ^q for each cell e_λ^q has been chosen for all $q < n$ such that the required conditions hold. Let e_λ^n be an n -cell of K , and let $e_{\mu 0}^{n-1}$ be an $(n - 1)$ -cell which is a face of e_λ^n . Once again, it is clear that we can choose one of the two possible orientations of e_λ^n , which we will denote by b_λ^n , so that

$$[b_\lambda^n : b_{\mu 0}^{n-1}] = \alpha_{\lambda\mu 0}^n. \quad (8.7.1)$$

We must prove that if e_{ν}^{n-1} is any other face of e_λ^n , then

$$[b_\lambda^n : b_\nu^{n-1}] = \alpha_{\lambda\nu}^n. \quad (8.7.2)$$

For this purpose, consider the subcomplex L of K consisting of all the cells of e_λ^n . Then

$$z = \sum_{\nu} \alpha_{\lambda\nu}^n b_\nu^{n-1},$$

where the summation is over all $(n - 1)$ -cells of L , is a nonzero $(n - 1)$ -chain of L . A routine calculation using the properties of regular cell complexes and the inductive hypothesis shows that

$$d_{n-1}(z) = 0,$$

i.e., z is a cycle. A similar argument shows that

$$z' = \sum_{\nu} [b_\lambda^n : b_\nu^{n-1}] b_\nu^{n-1}$$

is also a nonzero cycle. Since $e_\lambda^n = L^{n-1}$ is an $(n - 1)$ -sphere, it follows that

$$H_{n-1}(L) = Z_{n-1}(L)$$

is an infinite cyclic group. Therefore, z and z' are both multiples of a generator of this group. Since $\{b_\nu^{n-1}\}$ is a basis for $C_{n-1}(L)$, and we are assuming that Equation (8.7.1) holds, it follows that z and z' must be the *same* multiple of a generator of $Z_{n-1}(L)$, i.e., $z = z'$. By comparing coefficients of z and z' , we see

that (8.7.2) holds for all v . This completes the proof of the existence of the desired orientations.

The proof of uniqueness of orientations is also done by induction on n . For $n = 0$, orientations are unique by definition. Assume inductively that orientations have been proven unique for all cells of dimension $< n$; let e_λ^n be an n -cell. Choose an $(n - 1)$ -dimensional face e_μ^{n-1} of e_λ^n . By statement (d) of Lemma 5.1, changing the orientation of e_λ^n would change the incidence number $[b_\lambda^n : b_\mu^{n-1}]$, which is not allowed. Q.E.D.

Notational Convention. From now on, we will usually only need to consider one choice of orientation for the cells of a regular CW-complex. Therefore, we will use the same symbol for a cell and its orientation. Thus, $[e_\lambda^n : e_\mu^{n-1}] = 0$ or ± 1 denotes the incidence number of the *oriented* cells e_λ^n and e_μ^{n-1} . This calculated sloppiness in notation is customary and convenient.

The uniqueness statement of Theorem 7.2 is important, because it shows that we can specify orientations for the cells of a regular CW-complex by specifying a set of incidence numbers for the complex. This is one of the most convenient ways of specifying orientations of cells. Regular CW-complexes are often more convenient than other CW-complexes, because of this simple method for specifying the orientation of cells.

The method of using this theorem is quite simple. We assume we have given a list of cells of K together with the information as to whether $e_\lambda^{n-1} < e_\mu^n$ for any two cells e_λ^{n-1} and e_μ^n . For each 1-cell e^1 , choose incidence numbers between it and its two vertices so that conditions (2) and (3) of Lemma 7.1 (or Theorem 7.2) hold. Define all other incidence numbers between vertices and 1-cells to be 0 [condition (1)].

Now assume, inductively, that incidence numbers have been chosen between all cells of dimension $< n$. Let e^n be an n -cell. Choose a face e_0^{n-1} of e^n , and choose $[e^n : e_0^{n-1}]$ to be $+1$ or -1 . Using condition (4), determine $[e^n : e_\lambda^{n-1}]$ for all $(n - 1)$ -cells e_λ^{n-1} which are faces of e^n and have an $(n - 2)$ -face in common with e_0^{n-1} . Spread out over the boundary e^n by repeating this process. Theorem 7.2 assures us that we will never reach a contradiction by this process. Repeat this process for each n -cell of K , and then use condition (1) to define all other incidence numbers between $(n - 1)$ - and n -cells.

Here is a convenient way to indicate incidence relations between low-dimensional cells on a diagram:

(a) **Between 0-cells and 1-cells.** Let e^1 be a 1-cell with vertices e_0^0 and e_1^0 . Consider the two incidence numbers $[e^1 : e_0^0]$ and $[e^1 : e_1^0]$; one of these is 1 , the other is -1 . Draw an arrow on e^1 indicating the direction *from* the vertex corresponding to -1 to the vertex corresponding to $+1$ as in Figure 9.2.

(b) **Between 1-cells and 2-cells.** Let e^2 be a 2-cell and let e^1 be a face of e^2 , as shown in Figure 9.3. We assume the orientation chosen for e^1 is indicated by means of an arrow, as shown. Indicate the orientation of e^2 by indicating a direction of rotation of e^2 about its center. This direction of rotation will be the *same* as that indicated by the arrow on e^1 if $[e^2 : e^1] = +1$, otherwise it

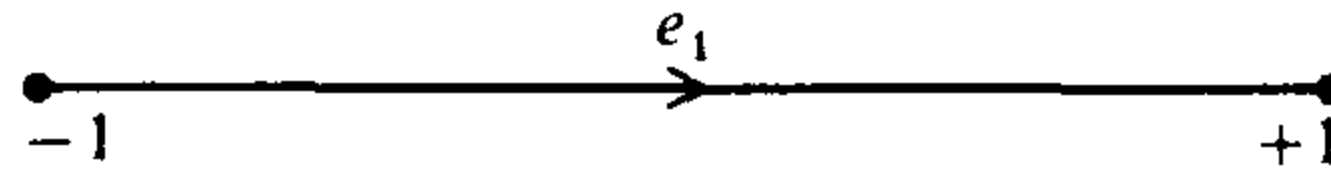

FIGURE 9.2

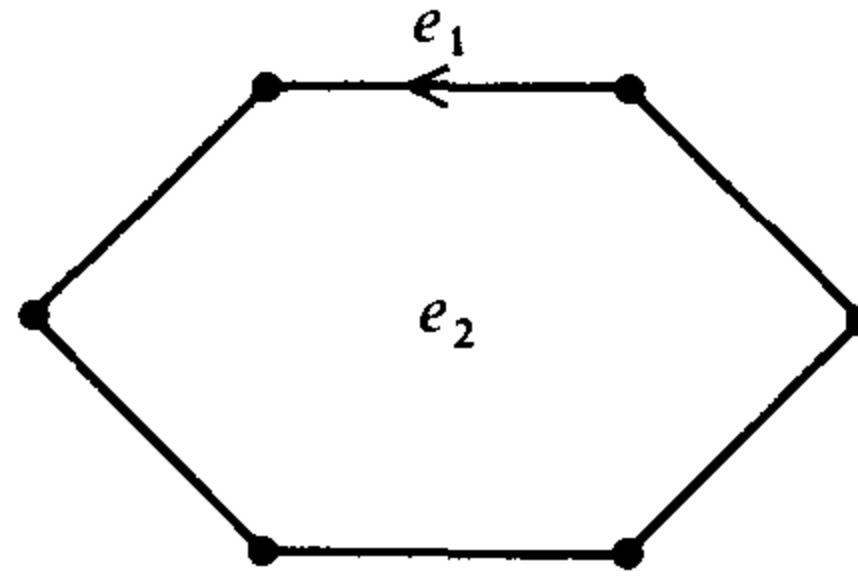

FIGURE 9.3

will be the opposite. Note that the resultant direction of rotation of e^2 is independent of the choice of the face e^1 .

(c) Between 2-cells and 3-cells. We can indicate orientations of 3-cells by assigning to them a right- or left-handed corkscrew. We assume that all the faces of a given 3-cell e^3 have their orientations indicated as described in the preceding paragraph. Let e^2 be a face of e^3 . If $[e^3 : e^2] = +1$, assign to e^3 the kind of corkscrew needed to *bore into* e^3 from the outside, through the face e^2 , rotating in the direction indicated by the orientation of e^2 . If $[e^3 : e^2] = -1$, assign to e^3 the kind of corkscrew needed to *bore out* of e^3 through the face e^2 , rotating in the direction indicated by the orientation of e^2 . Note once again that the type of corkscrew assigned to e^3 is independent of the choice of the face e^2 .

EXERCISES

- 7.1. Divide an orientable surface of genus n into $4n$ quadrilaterals. There will be $2n + 2$ vertices and $8n$ 1-cells. Figure 9.4 indicates the case $n = 2$:

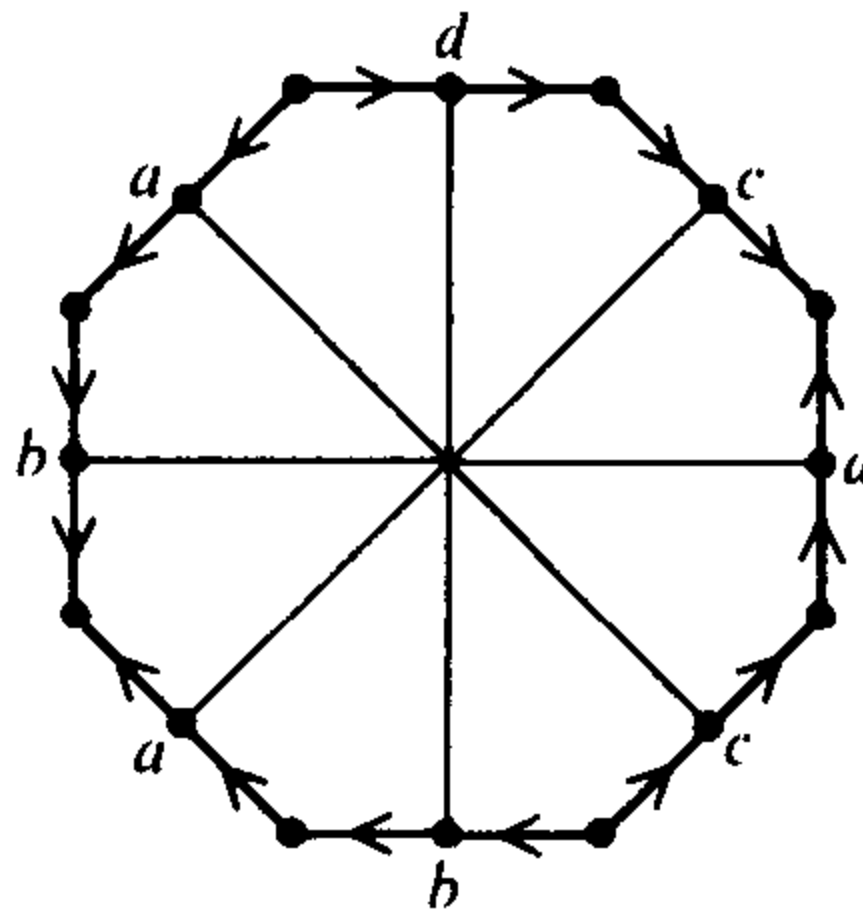

FIGURE 9.4

Compute incidence numbers.

7.2. Consider real projective 3-space as obtained by identifying diametrically opposite points on the boundary of the regular octahedron

$$\{(x, y, z) \in \mathbf{R}^3 \mid |x| + |y| + |z| \leq 1\}.$$

Divide the octahedron into eight tetrahedra by means of the coordinate planes (i.e., there is one tetrahedron in each octant). Compute incidence numbers. *Note:* This process can be generalized to define a regular CW-complex on real projective n -space.

7.3. Let K be a regular CW-complex on X . Define K to be an *almost simplicial complex* if the following conditions hold for all $n \geq 0$:

- (a) Each n -cell has exactly $n + 1$ vertices.
- (b) Any set of $n + 1$ vertices is the set of vertices of *at most* one n -cell (it need not be the set of vertices of any n -cell).

Prove the following two facts about almost simplicial complexes:

1. An n -cell has exactly $n + 1$ faces of dimension $n - 1$.
2. Incidence numbers for an almost simplicial complex can be described explicitly as follows: Each cell is uniquely described by listing its vertices. Linearly order all the vertices (in any order whatsoever) and agree to always list vertices in the given order. If e^n has vertices v_0, v_1, \dots, v_n in the given order, and the face e^{n-1} has only the vertex v_i omitted, then set $[e^n : e^{n-1}] = (-1)^i$.

(*Note:* A *simplicial complex*, as defined in most books, is an almost simplicial complex with certain additional geometric structure. This additional structure is irrelevant as far as computing homology groups is concerned.)

§8. Homology Groups of a Pseudomanifold

In this section we apply the results of §7 to determine the structure of certain homology groups of a special class of regular CW-complexes. This special class is of fairly wide occurrence.

Definition 8.1. An n -dimensional *pseudomanifold* is an n -dimensional finite, regular CW-complex which satisfies the following three conditions:

- (1) Every cell is a face of some n -cell.
- (2) Every $(n - 1)$ -dimensional cell is a face of exactly two n -cells.
- (3) Given any two n -cells, e^n and e''^n , there exists a sequence of n -cells

$$e_0^n, e_1^n, \dots, e_k^n$$

such that $e_0^n = e^n$, $e_k^n = e''^n$, and e_{i-1}^n and e_i^n have a common $(n - 1)$ -dimensional face ($i = 1, 2, \dots, k$).

Some authors call an n -dimensional pseudomanifold a *simple n -circuit*.

A regular CW-complex on a compact connected 2-manifold is an example of a 2-dimensional pseudomanifold. More generally it may be shown that a regular CW-complex on a compact connected n -manifold is an n -dimensional pseudomanifold. An example of a pseudomanifold which is not a manifold may be constructed as follows: Let K be a regular CW-complex on a compact, connected 2-manifold. Form the quotient by identifying two vertices which are not both vertices of the same 2-cell. The quotient space has an obvious structure of regular CW-complex, which may be shown to be a 2-dimensional pseudomanifold.

It may be proved that the above definition is “topologically invariant” in the sense that it expresses a condition on the underlying space rather than a condition on the particular regular CW-complex chosen on the space (a proof of this fact is contained in the book by Seifert and Threlfall [9, Chapter 5]).

Let K be an n -dimensional pseudomanifold, and let e_1^n and e_2^n be n -cells of K which have a common $(n - 1)$ -dimensional face e^{n-1} . We define orientations for e_1^n and e_2^n to be *coherent* (with respect to the common face e^{n-1}) if the incidence numbers satisfy the following relation:

$$[e_1^n : e^{n-1}] + [e_2^n : e^{n-1}] = 0.$$

Note that this condition is independent of the choice of the orientation for the cell e^{n-1} . A set of orientations for all the n -cells of K is said to be *coherent*, if it is coherent in the above sense for any pair of n -cells which have a common face of dimension $n - 1$.

In connection with the above definition, it should be pointed out that a pair of n -cells in an n -dimensional pseudomanifold may have more than one common $(n - 1)$ -dimensional face; in such a case it is essential to specify the common face with respect to which given orientations are asserted to be coherent. An example is the following subdivision of the projective plane with four vertices, v_1, \dots, v_4 , seven edges, e_1, \dots, e_7 , and four 2-cells, $A, B, C,$ and D (see Figure 9.5). The 2-cells A and B have the edges e_1 and e_3 in common;

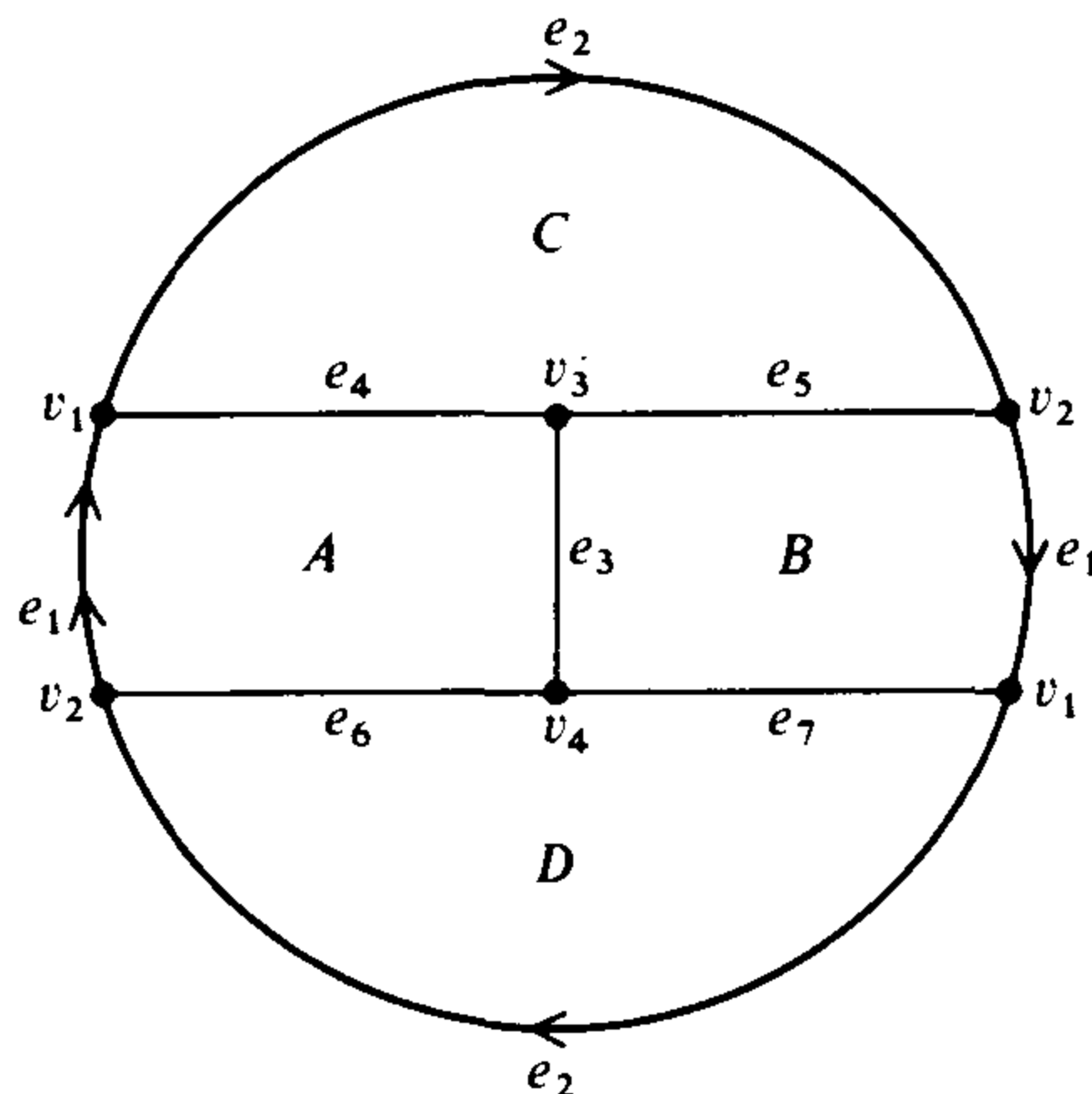

FIGURE 9.5

if A and B are oriented coherently with respect to the edges e_1 , the orientations are not coherent with respect to the edge e_3 , and vice versa.

Given an n -dimensional pseudomanifold K , either all the n -cells of K can be simultaneously oriented so any pair having a common $(n - 1)$ -dimensional face are oriented coherently, or they can not be so oriented. In the former case, K is said to be *orientable*, in the latter case *nonorientable*.

Theorem 8.2. *If K is an orientable n -dimensional pseudomanifold, then $H_n(K)$ is infinite cyclic; if K is nonorientable then $H_n(K) = 0$.*

The details of the proof are left to the reader. Note that since K is an n -dimensional CW-complex, $H_n(K) = Z_n(K)$. If K is orientable, and the n -cells are oriented so that any pair having a common face of dimension $n - 1$ are coherently oriented, then the sum of all the n -cells (thus oriented) is an n -cycle; moreover, any n -cycle is an integral multiple of this sum. If K is nonorientable, then one proves that there are no nonzero n -cycles.

In view of the invariance of the homology groups of a regular CW-complex K , this theorem shows that the concepts of *orientability* and *nonorientability* really only depend on the underlying topological space involved, and not on the choice of the regular cell complex K .

The next theorem describes the structure of the torsion subgroup of $H_{n-1}(K)$.

Theorem 8.3. *Let K be an n -dimensional pseudomanifold. If K is orientable, then $H_{n-1}(K)$ is torsion-free. If K is nonorientable, then the torsion subgroup of $H_{n-1}(K)$ is cyclic of order two.*

PROOF. Let k denote the number of n -cells of K . We assert that it is possible to enumerate the n -cells of K in order $e_1^n, e_2^n, \dots, e_k^n$ and to choose $(n - 1)$ -cells e_i^{n-1} , $2 \leq i \leq k$, of K such that the following condition holds: e_i^{n-1} is a common face of e_i^n and some n -cell e_j^n with $j < i$. The proof of this assertion is left to the reader.

Assume that the n -cells have been enumerated and the $(n - 1)$ -cells $e_2^{n-1}, \dots, e_k^{n-1}$ have been chosen so the above conditions hold. Choose an arbitrary orientation for the cell e_1^n ; then orient e_2^n so that its orientation is coherent to that of e_1^n with respect to the face e_2^{n-1} . Next orient e_3^n so it is coherent with respect to the face e_3^{n-1} to either e_1^n or e_2^n as is relevant. Continue in this manner, orienting all the n -cells in succession, so each e_i^n is coherently oriented with some e_j^n , $j < i$, with respect to e_i^{n-1} . Once the orientation of e_1^n is chosen, this condition uniquely determines the orientations of the rest of the n -cells. It is easy to see that if K is orientable, then the result is a coherent orientation of all the n -cells of K .

We next assert that any $(n - 1)$ -cycle z of K is homologous to a cycle z' such that the coefficient of each of the cells $e_2^{n-1}, \dots, e_k^{n-1}$ in z' is 0. The proof is left to the reader.

With these preparations out of the way, we can now prove the theorem.

Let u be a homology class of finite order of $H_{n-1}(K)$, i.e., $q \cdot u = 0$ for some integer q . Let $z \in Z_{n-1}(K)$ be a representative cycle for u . By the above argument, we may assume that the coefficients of the cells $e_2^{n-1}, \dots, e_k^{n-1}$ in the cycle z are all 0. Since $qu = 0$, there exists an n -chain

$$c = \sum_{i=1}^k \alpha_i e_i^n$$

such that

$$d(c) = q \cdot z.$$

In view of the way we have oriented the n -cells e_i^n , and the fact that the coefficients of $e_2^{n-1}, \dots, e_k^{n-1}$ are 0 in z , we conclude that

$$\alpha_1 = \alpha_2 = \dots = \alpha_k.$$

If K is orientable, we see that

$$d(c) = 0,$$

hence $q \cdot z = 0$, $z = 0$, and $u = 0$, as required. In the nonorientable case, consider the n -chain

$$c' = \sum_{i=1}^k e_i^n.$$

Then $d(c')$ is a nonzero $(n-1)$ -cycle which assigns the coefficient 0 or ± 2 to every $(n-1)$ -cell of K . Hence,

$$y = \frac{1}{2}d(c')$$

is an $(n-1)$ -dimensional cycle of K , and its homology class is an element of order 2 in $H_{n-1}(K)$. Note that the coefficient of any $(n-1)$ -cell is 0 or ± 1 in the expression for the cycle y . Since $c = \alpha c'$ for some integer α , we see that

$$d(c) = \alpha d(c'),$$

$$q \cdot z = 2\alpha y,$$

$$z = \frac{2\alpha}{q} y,$$

hence the homology class of z is a multiple of that of y . Thus, the torsion subgroup of $H_{n-1}(K)$ is the cyclic group generated by the homology class of y .

Q.E.D.

Since it may be shown that any regular CW-complex on a compact connected n -manifold is an n -dimensional pseudomanifold, the above results apply in particular to all compact n -manifolds which can be "subdivided" so as to define a regular CW-complex structure. It is known that every compact n -manifold admits such a subdivision if $n \leq 3$; however, there exist compact 4-dimensional manifolds which do not admit such a subdivision.

References

1. N. Bourbaki, *General Topology, Part 2*, Addison-Wesley, Reading, Mass., 1966.
2. G. E. Cooke and R. L. Finney, *Homology of Cell Complexes*, Princeton University Press, Princeton, N.J., 1967.
3. P. J. Hilton, *An Introduction Homotopy Theory*, Cambridge University Press, New York, 1953, Chapter VII.
4. S. T. Hu, *Elements of General Topology*, Holden-Day, San Francisco, 1964, Chapter IV.
5. A. T. Lundell and S. Weingram, *The Topology of CW-complexes*, Van Nostrand Reinhold Co., New York, 1969.
6. W. S. Massey, *Algebraic Topology: An Introduction*, Springer-Verlag, New York, 1977, pp. 215–217.
7. W. S. Massey, *Homology and Cohomology Theory: An Approach Based on Alexander-Spanier Cochains*, Marcel Dekker, Inc., New York, 1978, Chapter 5.
8. R. Brown, *Elements of Modern Topology*, McGraw-Hill Co., New York, 1968, Chapter 5.
9. H. Seifert and W. Threlfall, *A Textbook of Topology*, Academic Press, New York, 1980.
10. J. H. C. Whitehead, Combinatorial homotopy I, *Bull Am. Math. Soc.* **55** (1949), 213–245.

CHAPTER X

Homology with Arbitrary Coefficient Groups

§1. Introduction

This chapter is more algebraic in nature than the preceding chapters. In §2 we discuss chain complexes. This discussion mainly puts on a formal basis many facts that the reader must know by now. Nevertheless, there *is* some point to a systematic organization of the ideas involved, and certain new ideas and techniques are introduced. The remainder of the chapter is concerned with homology groups with arbitrary coefficients. These new homology groups are a generalization of those we have considered up to now. In the application of homology theory to certain problems they are often convenient and sometimes necessary.

Starting in §3, we make systematic use of tensor products. It is assumed that the reader knows the definition and basic properties of tensor products of abelian groups.

§2. Chain Complexes

Much of this section consists of terminology and definitions which it will be very convenient to use from now on.

Definition 2.1. A *chain complex* $K = \{K_n, \partial_n\}$ is a sequence of abelian groups K_n , $n = 0, \pm 1, \pm 2, \dots$, and a sequence of homomorphisms $\partial_n : K_n \rightarrow K_{n-1}$ which are required to satisfy the condition

$$\partial_{n-1} \partial_n = 0$$

for all n .

For any such chain complex $K = \{K_n, \partial_n\}$ we define

$$Z_n(K) = \text{kernel } \partial_n,$$

$$B_n(K) = \text{image } \partial_{n+1}.$$

Then $B_n(K) \subset Z_n(K) \subset K_n$, and we can define

$$H_n(K) = Z_n(K)/B_n(K),$$

called the n th *homology group* of K .

Example

2.1. For any space X , we have previously defined the chain complexes

$$Q(X) = \{Q_n(X), \partial_n\},$$

$$D(X) = \{D_n(X), \partial_n\},$$

$$C(X) = \{C_n(X), \partial_n\},$$

and for any pair (X, A) ,

$$C(X, A) = \{C_n(X, A), \partial_n\}.$$

Definition 2.2. Let $K = \{K_n, \partial_n\}$ and $K' = \{K'_n, \partial'_n\}$ be chain complexes. A *chain map* $f: K \rightarrow K'$ consists of a sequence of homomorphisms $f_n: K_n \rightarrow K'_n$ such that the commutativity condition

$$f_{n-1}\partial_n = \partial'_n f_n$$

holds for all n .

Examples

2.2. A continuous map $\varphi: X \rightarrow Y$ induces chain maps

$$\varphi_\# : Q(X) \rightarrow Q(Y),$$

$$\varphi_\# : D(X) \rightarrow D(Y),$$

$$\varphi_\# : C(X) \rightarrow C(Y),$$

etc.

If $f: K \rightarrow K'$ is a chain map, then $f_n[Z_n(K)] \subset Z_n(K')$ and $f_n[B_n(K)] \subset B_n(K')$; hence, there is induced a homomorphism

$$f_* : H_n(K) \rightarrow H_n(K')$$

for all n .

Note that the set of all chain complexes and chain maps constitutes a category, and that H_n is a functor from this category to the category of abelian groups and homomorphisms. Note also that if f and $g: K \rightarrow K'$ are chain

maps, their *sum*,

$$f + g = \{f_n + g_n\},$$

is also a chain map, and

$$(f + g)_* = f_* + g_* : H_n(K) \rightarrow H_n(K').$$

In other words, H_n is an *additive functor*.

Definition 2.3. Let $f, g : K \rightarrow K'$ be chain maps. A *chain homotopy* $D : K \rightarrow K'$ between f and g is a sequence of homomorphisms

$$D_n : K_n \rightarrow K'_{n+1}$$

such that

$$f_n - g_n = \partial'_{n+1} D_n + D_{n-1} \partial_n$$

for all n . Two chain maps are said to be *chain homotopic* if there exists a chain homotopy between them (notation: $f \simeq g$).

Examples

2.3. If $\varphi_0, \varphi_1 : X \rightarrow Y$ are continuous maps, any homotopy between φ_0 and φ_1 gives rise to a chain homotopy between the induced chain maps $\varphi_{0\#}$ and $\varphi_{1\#}$ on cubical singular chains (see §VII.4).

The reader should prove the following two facts for himself:

Proposition 2.4. Let $f, g : K \rightarrow K'$ be chain maps. If f and g are chain homotopic, then

$$f_* = g_* : H_n(K) \rightarrow H_n(K')$$

for all n .

Proposition 2.5. Chain homotopy is an equivalence relation on the set of all chain maps from K to K' .

EXERCISES

2.1. By analogy with the category of topological spaces and continuous maps, complete the following definitions:

- (a) A chain map $f : K \rightarrow K'$ is a *chain homotopy equivalence* if _____ .
- (b) A chain complex K' is a *subcomplex* of the chain complex K if _____ .
- (c) A subcomplex K' of the chain complex K is a *retract* of K if _____ .
- (d) A subcomplex K' of the chain complex K is a *deformation retract* of K if _____ .
- (e) If K' is a subcomplex of K , the quotient complex K/K' is _____ .

In each case, what assertions can be made about the homology groups of the various chain complexes involved, and about the homomorphisms induced by the various chain maps?

- 2.2. Let $f, g, f',$ and g' be chain maps $K \rightarrow K'$. If f is chain homotopic to f' , and g is chain homotopic to g' , then prove that $f + g$ is chain homotopic to $f' + g'$.
- 2.3. Let $f, g: K \rightarrow K'$ and $f', g': K' \rightarrow K''$ be chain maps, D a chain homotopy between f and g , and D' a chain homotopy between f' and g' . Using D and D' , construct an explicit chain homotopy between $f'f$ and $g'g: K \rightarrow K''$.
- 2.4. Let D be a chain homotopy between the maps f and $g: K \rightarrow K$ (of K into itself). Use D to construct an explicit chain homotopy between $f^n = fff \cdots f$ and $g^n = gg \cdots g$ (n -fold iterates).

Definition 2.6. A sequence of chain complexes and chain maps

$$\cdots \rightarrow K \xrightarrow{f} K' \xrightarrow{g} K'' \rightarrow \cdots$$

is *exact* if for each integer n the sequence of abelian groups

$$\cdots \rightarrow K_n \xrightarrow{f_n} K'_n \xrightarrow{g_n} K''_n \rightarrow \cdots$$

is exact in the usual sense.

We will be especially interested in *short* exact sequences of chain complexes, i.e., those of the form

$$E: 0 \rightarrow K' \xrightarrow{f} K \xrightarrow{g} K'' \rightarrow 0.$$

This means that for each n , f_n is an monomorphism, g_n is an epimorphism, and image $f_n = \text{kernel } g_n$. Given any such short exact sequence of chain complexes, we can follow the procedure of §VII.5 to define a *connecting homomorphism* or *boundary operator*

$$\partial_E: H_n(K'') \rightarrow H_{n-1}(K')$$

for all n , and then prove that the following sequence of abelian groups

$$\cdots \xrightarrow{\partial_E} H_n(K') \xrightarrow{f_*} H_n(K) \xrightarrow{g_*} H_n(K'') \xrightarrow{\partial_E} H_{n-1}(K') \rightarrow \cdots$$

is exact. One can also prove that following important naturality property of this connecting homomorphism or boundary operator: Let

$$\begin{array}{ccccccccc}
 E: & 0 & \longrightarrow & K' & \xrightarrow{f} & K & \xrightarrow{g} & K'' & \longrightarrow & 0 \\
 & & & \downarrow \varphi & & \downarrow \psi & & \downarrow \omega & & \\
 F: & 0 & \longrightarrow & L' & \xrightarrow{h} & L & \xrightarrow{i} & L'' & \longrightarrow & 0
 \end{array}$$

be a commutative diagram of chain complexes and chain maps. It is assumed that the two rows, denoted by E and F , are short exact sequences. Then the

following diagram is commutative for each n :

$$\begin{array}{ccc} H_n(K'') & \xrightarrow{\partial_E} & H_{n-1}(K') \\ \downarrow \omega_* & & \downarrow \varphi_* \\ H_n(L'') & \xrightarrow{\partial_F} & H_{n-1}(L') \end{array}$$

EXERCISES

- 2.5. Define the direct sum and direct product of an arbitrary family of chain complexes in the obvious way. How is the homology of such a direct sum or product related to the homology of the individual chain complexes of the family?
- 2.6. Let $E: 0 \rightarrow K' \xrightarrow{f} K \xrightarrow{g} K'' \rightarrow 0$ be a short exact sequence of chain complexes. By a *splitting homomorphism* for such a sequence we mean a sequence $s = \{s_n\}$ such that for each n , $s_n: K''_n \rightarrow K_n$, and $g_n s_n = \text{identity map of } K''_n \text{ onto itself}$. Note that we do *not* demand that s should be a chain map. Assume that such a splitting homomorphism exists.

- (a) Prove that there exist unique homomorphisms $\varphi_n: K''_n \rightarrow K'_{n-1}$ for all n such that

$$f_{n-1} \varphi_n = \partial_n s_n - s_{n-1} \partial''_n.$$

- (b) Prove that $\partial'_{n-1} \varphi_n + \varphi_{n-1} \partial''_n = 0$ for all n .
- (c) Let $s' = \{s'_n\}$ be another sequence of splitting homomorphisms, and $\varphi'_n: K''_n \rightarrow K'_{n-1}$ the unique homomorphisms such that $f_{n-1} \varphi'_n = \partial_n s'_n - s'_{n-1} \partial''_n$. Prove that there exists a sequence of homomorphisms $D_n: K''_n \rightarrow K'_n$ such that

$$\varphi_n - \varphi'_n = \partial'_n D_n - D_{n-1} \partial''_n$$

for all n .

- (d) Prove that the connecting homomorphism $\partial_E: H_n(K'') \rightarrow H_{n-1}(K')$ is induced by the sequence of homomorphisms $\{\varphi_n\}$ in the same sense that a chain map induces homomorphisms of homology groups. (Note: The sequence of homomorphisms $\{\varphi_n\}$ can be thought of as a “chain map of degree -1 .” The sequence of homomorphisms $\{D_n\}$ in Part (c) is a chain homotopy between $\{\varphi_n\}$ and $\{\varphi'_n\}$.)

We will conclude this section on chain complexes with a discussion of a construction called the algebraic mapping cone of a chain map.

Definition 2.7. Let $K = \{K_n, \partial_n\}$ and $K' = \{K'_n, \partial'_n\}$ be chain complexes and $f: K \rightarrow K'$ a chain map. The algebraic mapping cone of f , denoted by $M(f) = \{M(f)_n, d_n\}$ is a chain complex defined as follows:

$$M(f)_n = K_{n-1} \oplus K'_n \quad (\text{direct sum}).$$

The boundary operator $d_n: M(f)_n \rightarrow M(f)_{n-1}$ is defined by

$$d_n(x, x') = (-\partial_{n-1}x, \partial'_n x' + f_{n-1}x)$$

for any $x \in K_{n-1}$ and $x' \in K'_n$. It is trivial to verify that $d_{n-1}d_n = 0$.

Next, define $i_n : K'_n \rightarrow M(f)_n$ by $i_n(x') = (0, x')$. The sequence of homomorphisms $i = \{i_n\}$ is easily seen to be a chain map $K' \rightarrow M(f)$. Similarly, the sequence of projections $j_n : M(f)_n \rightarrow K_{n-1}$ [defined by $j_n(x, x') = x$] is almost a chain map. However, it reduces degrees by one, and instead of commuting with the boundary operators, we have the relation

$$\partial_{n-1}j_n = -j_{n-1}d_n.$$

It is a “chain map of degree -1 .” It induces a homomorphism of homology groups which reduces degrees by 1.

The chain maps i and j define a short exact sequence of chain complexes:

$$0 \rightarrow K' \xrightarrow{i} M(f) \xrightarrow{j} K \rightarrow 0.$$

As usual, this short exact sequence of chain complexes gives rise to a long exact homology sequence:

$$\cdots \rightarrow H_n(K') \xrightarrow{i_*} H_n(M(f)) \xrightarrow{j_*} H_{n-1}(K) \xrightarrow{d_*} H_{n-1}(K') \rightarrow \cdots$$

Here d_* denotes the connecting homomorphism. It is now an easy matter to check that

$$d_* = f_* : H_n(K) \rightarrow H_n(K')$$

for all n . Thus we have imbedded the homomorphisms f_* induced by the given chain map in a long exact sequence; and this has been done in a natural way. That is the whole point of introducing the algebraic mapping cone. The long exact sequence will be called the *exact homology sequence of f* .

Remark. The topological analog of this construction is described in §XV.3.

Our first application of the algebraic mapping cone is to prove the following basic theorem. We will see other applications later on.

Theorem 2.8. *Let $K = \{K_n, \partial_n\}$ and $K' = \{K'_n, \partial'_n\}$ be chain complexes such that K_n and K'_n are free abelian groups for all n . Then a chain map $f : K \rightarrow K'$ is a chain homotopy equivalence if and only if the induced homomorphism $f_* : H_n(K) \rightarrow H_n(K')$ is an isomorphism for all n .*

The *only if* part of this theorem is a triviality, hence will be concerned only with the *if* part. First, we need a couple of lemmas.

Recall that if the identity map and the zero map of a chain complex K into itself are chain homotopic, then $H_n(K) = 0$ for all n . The first lemma is a partial converse of this statement.

Lemma 2.9. *Let K be a chain complex such that $Z_n(K)$ is a direct summand of K_n for all n , and $H_n(K) = 0$ for all n . Then the identity map and the zero map of K into itself are chain homotopic.*

PROOF. For each n , choose a direct sum decomposition

$$K_n = Z_n(K) \oplus A_n.$$

Since $H_n(K) = 0$, $B_n(K) = Z_n(K)$ for all n . It follows that ∂_n maps A_n isomorphically onto $Z_{n-1}(K)$. We now define the chain homotopy $D_n: K_n \rightarrow K_{n+1}$ as follows: D_n restricted to A_n is the zero map, and D_n restricted to $Z_n(K)$ shall map $Z_n(K)$ isomorphically onto A_{n+1} by the inverse of the isomorphism ∂_{n+1} . It is now easily verified that

$$D_{n-1}\partial_n(x) + \partial_{n+1}D_n(x) = x$$

for any $x \in K_n$.

Q.E.D.

Lemma 2.10. *Let K be a chain complex such that K_n is a free abelian group. Then $Z_{n+1}(K)$ is a direct summand of K_{n+1} .*

PROOF. Since K_n is free abelian, it follows by a standard theorem of algebra that the subgroup $B_n(K)$ is also free abelian. Because ∂_{n+1} is a homomorphism of K_{n+1} onto the free group $B_n(K)$, we can conclude that $Z_{n+1}(K) = \text{kernel } \partial_{n+1}$ is a direct summand. Q.E.D.

PROOF OF THEOREM 2.8. We assume that the induced homomorphism $f_*: H_n(K) \rightarrow H_n(K')$ is an isomorphism for all n , and will prove that f is a chain homotopy equivalence. Let $M(f)$ denote the algebraic mapping cone of f ; our assumption implies that $H_n(M(f)) = 0$ for all n . Since K and K' are both chain complexes of free abelian groups, it follows that $M(f)$ is also a chain complex of free abelian groups. Hence $Z_n(M(f))$ is a direct summand of $M(f)_n$ for all n by Lemma 2.10. Therefore we can apply Lemma 2.9 to $M(f)$ to conclude that there exists a chain homotopy $D_n: M(f)_n \rightarrow M(f)_{n+1}$ such that

$$d_{n+1}D_n(a) + D_{n-1}d_n(a) = a \quad (10.2.1)$$

for any $a \in M(f)_n$. Making use of the fact that $M(f)_n$ is a direct sum for any n , we see that there exist unique homomorphisms

$$D_n^{11}: K_{n-1} \rightarrow K_n,$$

$$D_n^{12}: K'_n \rightarrow K_n,$$

$$D_n^{21}: K_{n-1} \rightarrow K'_{n+1},$$

$$D_n^{22}: K'_n \rightarrow K'_{n+1},$$

such that

$$D_n(x, x') = (D_n^{11}x + D_n^{12}x', D_n^{21}x + D_n^{22}x')$$

for any $x \in K_{n-1}$ and $x' \in K'_n$. With this notation, Equation (10.2.1) is equivalent to the following four equations:

$$-\partial_n D_n^{11} - D_n^{11} \partial_{n-1} + D_{n-1}^{12} f_{n-1} = 1, \tag{10.2.2}$$

$$-\partial_n D_n^{12} + D_{n-1}^{12} \partial'_n = 0, \tag{10.2.3}$$

$$f_n D_n^{11} + \partial'_{n+1} D_n^{21} - D_{n-1}^{21} \partial_{n-1} + D_{n-1}^{22} f_{n-1} = 0 \tag{10.2.4}$$

$$f_n D_n^{12} + \partial'_{n+1} D_n^{22} + D_{n-1}^{22} \partial'_n = 1'. \tag{10.2.5}$$

In these equations, the symbols 1 and 1' denote the identity maps of the chain complexes K and K' , respectively. Equation (10.2.3) implies that the sequence of homomorphisms $D^{12} = \{D_n^{12}\}$ is a chain map $K' \rightarrow K$. Similarly, Equation (10.2.2) implies that

$$D^{12} f \simeq 1,$$

whereas Equation (10.2.5) implies that

$$f D^{12} \simeq 1',$$

This completes the proof.

Q.E.D.

EXERCISES

2.7. Assume we have given a commutative diagram

$$\begin{array}{ccc} K & \xrightarrow{f} & K' \\ \downarrow \varphi & & \downarrow \psi \\ L & \xrightarrow{g} & L' \end{array}$$

of chain complexes and chain maps. Show that the pair of chain maps (φ, ψ) induces a chain map $M(f) \rightarrow M(g)$ and gives rise to a commutative diagram involving the exact homology sequences of f and g (this is a naturality statement for the algebraic mapping cone).

2.8. Let $f, g : K \rightarrow K'$ be chain maps. Show that any chain homotopy D between f and g gives rise to a chain map $M(f) \rightarrow M(g)$ which induces isomorphisms $H_n(M(f)) \approx H_n(M(g))$ for all n . What is the relation between the exact homology sequences of f and g in this case?

2.9. Assume that

$$E : 0 \rightarrow K \xrightarrow{f} K' \xrightarrow{g} K'' \rightarrow 0$$

is a short sequence of chain complexes and chain maps. Prove that the exact homology sequence of f and the exact homology sequence of g are both isomorphic to the exact homology sequence of E .

§3. Definition and Basic Properties of Homology with Arbitrary Coefficients

In VII.2 we defined an element of the group $Q_n(X)$ to be a finite linear combination $a_1 T_1 + a_2 T_2 + \cdots + a_k T_k$ of singular n -cubes with integral coefficients. As the reader may have already suspected, one could equally well use linear combinations of n -cubes with coefficients in an arbitrary ring, rather than the ring of integers. In fact, one can even go further, and allow the coefficients a_1, a_2, \dots above to be elements of an arbitrary abelian group (written additively). It turns out that the entire theory we have developed so far can be redone with very little change with this added degree of generality. For certain problems the resulting homology groups with other coefficients are more convenient, or perhaps even essential. Examples to illustrate this point will be given later.

For our purposes, it will be quicker and more convenient to develop the properties of homology groups with arbitrary coefficients by using the theory of tensor products. This we will now proceed to do. The motivation for this approach is as follows: Recall that $Q_n(X)$ is a free abelian group with basis consisting of the set of singular n -cubes in X . Let G be an abelian group. It follows that any element of the group $G \otimes Q_n(X)$ has a *unique* expression of the form

$$a_1 \otimes T_1 + a_2 \otimes T_2 + \cdots + a_k \otimes T_k,$$

where T_1, T_2, \dots are singular n -cubes in X , and a_1, a_2, \dots are elements of the given group G . We can look at this expression as a linear combination of the singular n -cubes T_1, T_2, \dots with coefficients in G , as desired. This motivates the following definition.

Definition 3.1. Let $K = \{K_n, \partial_n\}$ be a chain complex and G an abelian group. Then $K \otimes G$ denotes the chain complex $\{K_n \otimes G, \partial_n \otimes 1_G\}$, where 1_G denotes the identity map of G . If $f = \{f_n\}$ is a chain map $K \rightarrow L$, then $f \otimes 1_G : K \otimes G \rightarrow L \otimes G$ denotes the chain map $\{f_n \otimes 1_G\}$. Finally, if $D : K \rightarrow L$ is a chain homotopy between f and $g : K \rightarrow L$, then $D \otimes 1_G : K \otimes G \rightarrow L \otimes G$ denotes the chain homotopy $\{D_n \otimes 1\}$ between $f \otimes 1$ and $g \otimes 1$.

Of course, in the above definition it is necessary to verify that $K \otimes G$ is actually a chain complex, that $f \otimes 1_G$ is a chain map, and that $D \otimes 1_G$ is a chain homotopy between $f \otimes 1_G$ and $g \otimes 1_G$. However, these are trivialities. A more serious problem is the following: Suppose that

$$0 \rightarrow K' \xrightarrow{f} K \xrightarrow{g} K'' \rightarrow 0 \quad (10.3.1)$$

is a short exact sequence of chain complexes and chain maps. We would like to be able to conclude that for *any* abelian group G , the sequence

$$0 \longrightarrow K' \otimes G \xrightarrow{f \otimes 1} K \otimes G \xrightarrow{g \otimes 1} K'' \otimes G \longrightarrow 0 \quad (10.3.2)$$

is also exact. Then we could define the corresponding long exact homology sequence. Unfortunately, it is generally not true that Sequence (10.3.2) will be exact; all we can expect is that the sequence

$$K' \otimes G \xrightarrow{f \otimes 1} K \otimes G \xrightarrow{g \otimes 1} K'' \otimes G \longrightarrow 0$$

will be exact (right exactness of the tensor product). Thus, we will not be able to define a long exact homology sequence without some further assumptions. Experience has shown that the following assumption suffices for most of the applications we have in mind. Define a short exact sequence of chain complexes

$$0 \rightarrow K' \xrightarrow{f} K \xrightarrow{g} K'' \rightarrow 0$$

to be *split*, or *split exact*, if for each integer n , image f_n is a direct summand of K_n . Alternatively, we can require that for each integer n there exists a homomorphism $s_n: K''_n \rightarrow K_n$ such that $g_n s_n = \text{identity map of } K''_n$ (such a homomorphism is called a *splitting homomorphism*). Note that we do *not* require that the sequence of homomorphisms s_n should be a chain map; such an assumption would be far too strong for our purposes.

Lemma 3.2. *If the sequence $0 \rightarrow K' \xrightarrow{f} K \xrightarrow{g} K'' \rightarrow 0$ is split exact, then so is the sequence $0 \rightarrow K' \otimes G \xrightarrow{f \otimes 1} K \otimes G \xrightarrow{g \otimes 1} K'' \otimes G \rightarrow 0$.*

In fact, if $\{s_n\}$ is a sequence of splitting homomorphisms for the original short exact sequence, then $\{s_n \otimes 1\}$ is a sequence of splitting homomorphisms for the second sequence.

Lemma 3.3. *If K'' is a chain complex of free abelian groups, then any short exact sequence $0 \rightarrow K' \rightarrow K \rightarrow K'' \rightarrow 0$ is split exact.*

The proof is easy.

Since most of the chain complexes we will encounter are composed of free abelian groups, this lemma will find frequent application.

We will now apply these ideas to the homology groups of topological spaces.

Given any topological space X , we have the following short exact sequence of chain complexes:

$$0 \rightarrow D(X) \rightarrow Q(X) \rightarrow C(X) \rightarrow 0.$$

All three of these chain complexes consist of free abelian groups, and the sequence is split exact. Therefore, if we define new chain complexes as follows:

$$D(X; G) = D(X) \otimes G,$$

$$Q(X; G) = Q(X) \otimes G,$$

$$C(X; G) = C(X) \otimes G,$$

then the resulting sequence

$$0 \rightarrow D(X; G) \rightarrow Q(X; G) \rightarrow C(X; G) \rightarrow 0$$

is also split exact. Thus, we can consider $D_n(X; G) = D_n(X) \otimes G$ as a subgroup of $Q_n(X; G) = Q_n(X) \otimes G$, and $C_n(X; G)$ is the quotient group, $Q_n(X; G)/D_n(X; G)$. As was remarked above, an element of $Q_n(X; G)$ has a unique expression as a linear combination of singular n -cubes in X with coefficients in G ; obviously, $D_n(X; G)$ is the subgroup consisting of linear combinations of degenerate singular cubes.

If A is any subspace of X , we have the short exact sequence of chain complexes:

$$0 \rightarrow C(A) \xrightarrow{i} C(X) \xrightarrow{j} C(X, A) \rightarrow 0.$$

Once again each of the chain complexes consists of free abelian groups and the sequence is split exact. Therefore, if we define

$$C(X, A; G) = C(X, A) \otimes G,$$

then the resulting sequence

$$0 \longrightarrow C(A; G) \xrightarrow{i \otimes 1} C(X; G) \xrightarrow{j \otimes 1} C(X, A; G) \longrightarrow 0$$

is also split exact. Thus, we can regard $C_n(A; G)$ as a subgroup of $C_n(X; G)$, and $C_n(X, A; G)$ is the quotient group $C_n(X; G)/C_n(A; G)$. It is customary to denote the group $H_n(C(X, A; G))$ by the notation $H_n(X, A; G)$ and call it the *relative homology group of (X, A) with coefficient group G* .

If $\varphi : (X, A) \rightarrow (Y, B)$ is a continuous map of one pair of spaces into another, then we have the induced chain map

$$\varphi_{\#} : C(X, A) \rightarrow C(Y, B).$$

Hence, we get in induced chain map

$$\varphi_{\#} \otimes 1_G : C(X, A; G) \rightarrow C(Y, B; G)$$

and an induced homomorphism of homology groups, which we will denote by

$$\varphi_{*} : H_n(X, A; G) \rightarrow H_n(Y, B; G).$$

If two maps $\varphi_0, \varphi_1 : (X, A) \rightarrow (Y, B)$ are homotopic (as maps of pairs), then any homotopy between them defines a chain homotopy $D : C(X, A) \rightarrow C(Y, B)$ between the chain maps

$$\varphi_{0\#}, \varphi_{1\#} : C(X, A) \rightarrow C(Y, B)$$

(see §VII.4). Hence, $D \otimes 1_G$ is a chain homotopy between $\varphi_{0\#} \otimes 1_G$ and $\varphi_{1\#} \otimes 1_G$. It follows that the induced homomorphisms

$$\varphi_{0*}, \varphi_{1*} : H_n(X, A; G) \rightarrow H_n(Y, B; G)$$

are the same.

It is now an easy matter to check that all the properties of homology theory which were proved in §§VII.2–VII.5 remain true for homology theory with coefficients in an abelian group G . In particular, given any pair (X, A) , we have a *natural* exact homology sequence,

$$\cdots \xrightarrow{\partial_*} H_n(A; G) \xrightarrow{i_*} H_n(X; G) \xrightarrow{j_*} H_n(X, A; G) \xrightarrow{\partial_*} \cdots.$$

Also, one can check by direct computation that if P is a space consisting of a single point,

$$H_q(P; G) = \begin{cases} G & \text{for } q = 0 \\ \{0\} & \text{for } q \neq 0. \end{cases}$$

In order to define reduced homology groups in dimension 0, it is convenient for any space $X \neq \emptyset$ to define the *augmented* chain complex $\tilde{C}(X)$ as follows:

$$\begin{aligned} \tilde{C}_q(X) &= C_q(X) & \text{if } q \neq -1, \\ \tilde{C}_{-1}(X) &= Z, \\ \tilde{\partial}_q &= \partial_q & \text{if } q \neq 0 \text{ or } -1, \\ \tilde{\partial}_0 &= \varepsilon & \text{(see §VII.2),} \\ \tilde{\partial}_{-1} &= 0. \end{aligned}$$

Then $\tilde{H}_q(X) = H_q(\tilde{C}(X))$. We next define

$$\begin{aligned} \tilde{C}(X; G) &= \tilde{C}(X) \otimes G, \\ \tilde{H}_q(X; G) &= H_q(\tilde{C}(X; G)). \end{aligned}$$

One readily verifies that

$$\tilde{H}_q(X; G) = H_q(X; G) \quad \text{if } q \neq 0,$$

whereas for $q = 0$ there is a split exact sequence

$$0 \rightarrow \tilde{H}_0(X; G) \rightarrow H_0(X, G) \xrightarrow{\varepsilon_*} G \rightarrow 0$$

relating the reduced and unreduced 0-dimensional homology groups.

In order to prove the excision property for homology with arbitrary coefficients, it is convenient to have the following lemma.

Lemma 3.4. *Let K and K' be chain complexes of free abelian groups, and let $f: K \rightarrow K'$ be a chain map such that the induced homomorphism $f_*: H_n(K) \rightarrow H_n(K')$ is an isomorphism for all n . Then for any coefficient group G , the chain map $f \otimes 1_G: K \otimes G \rightarrow K' \otimes G$ also induces isomorphisms*

$$(f \otimes 1_G)_*: H_n(K \otimes G) \approx H_n(K' \otimes G)$$

for all n .

PROOF. By Theorem 2.8, f is a chain homotopy equivalence. It follows readily that $f \otimes 1_G: K \otimes G \rightarrow K' \otimes G$ is also a chain homotopy equivalence. Hence, $(f \otimes 1_G)_*$ is an isomorphism, as required. Q.E.D.

Now suppose that the hypotheses of the excision property hold as stated in Theorem VII.6.2, i.e., (X, A) is a pair and W is a subset of A such that \overline{W} is contained in the interior of A . Then it should be clear how to apply the lemma we have just proved in order to conclude that the inclusion map $(X - W, A - W) \rightarrow (X, A)$ induces an isomorphism $H_n(X - W, A - W; G) \approx H_n(X, A; G)$ for any n . Thus the excision property also holds true for homology with coefficients in any group G .

In a similar way, one can use Lemma 3.4 to prove that Theorem VII.6.4 holds true for homology with coefficients in an arbitrary group G : If \mathcal{U} is a generalized open covering of C , then the chain map

$$\sigma \otimes 1_G: C(X, A, \mathcal{U}) \otimes G \rightarrow C(X, A) \otimes G$$

induces isomorphisms on homology groups. This result can then be used to prove the exactness of the Mayer–Vietoris sequence (Theorem VIII.5.1) for homology with coefficient group G . The details are left to the reader.

Later on in this chapter, we will indicate an alternative method of proving the excision property and exactness of the Mayer–Vietoris sequence without using Theorem 2.8.

§4. Intuitive Geometric Picture of a Cycle with Coefficients in G

In Chapter VI we emphasized the intuitive picture of a 1-cycle as a collection of oriented closed curves with integral “multiplicities” attached to each, a 2-cycle as a collection of oriented closed surfaces, etc. The intuitive picture of a cycle with coefficients in a group G is basically similar, except now the multiplicity assigned to each closed curve or closed surface must be an element of G rather than an integer.

If the group G has elements of finite order, then certain new possibilities arise. For example, suppose G is a cyclic group of order n generated by an element of $g \in G$. Let x and y be distinct points in the space X , and suppose we have n distinct oriented curves in X , starting at x and ending at y . If the element g is assigned as the multiplicity of each curve, then the “sum” of all these oriented curves is a 1-cycle, because $n \cdot g = 0$.

If the group G is infinitely divisible, certain other new phenomena occur. Consider, for example, the case where G is the additive group of rational numbers. Suppose that z is an n -dimensional cycle in X with coefficient group G , and the qz is homologous to 0 for some integer $q \neq 0$. Since we can divide by q in this case, we can conclude that z is homologous to 0.

The above are just examples of two of the many things that can occur. The reader will undoubtedly encounter other examples as he proceeds in the study of this subject.

§5. Coefficient Homomorphisms and Coefficient Exact Sequences

Let $h: G_1 \rightarrow G_2$ be a homomorphism of abelian groups. Then we get an obvious homomorphism

$$1 \otimes h: C_n(X, A; G_1) \rightarrow C_n(X, A; G_2)$$

for any pair (X, A) and all integers n . These homomorphisms fit together to define a chain map $C(X, A; G_1) \rightarrow C(X, A; G_2)$ which we may as well continue to denote by the same symbol, $1 \otimes h$, and hence there is an induced homomorphism

$$h_{\#}: H_n(X, A; G_1) \rightarrow H_n(X, A; G_2).$$

The reader should verify the following two naturality properties of this induced homomorphism:

(a) For any continuous map $f: (X, A) \rightarrow (Y, B)$, the following diagram is commutative:

$$\begin{array}{ccc} H_n(X, A; G_1) & \xrightarrow{f_*} & H_n(Y, B; G_1) \\ \downarrow h_{\#} & & \downarrow h_{\#} \\ H_n(X, A; G_2) & \xrightarrow{f_*} & H_n(Y, B; G_2) \end{array}$$

(b) For any pair (X, A) , the following diagram is commutative:

$$\begin{array}{ccc} H_n(X, A; G_1) & \xrightarrow{\partial_*} & H_{n-1}(A; G_1) \\ \downarrow h_{\#} & & \downarrow h_{\#} \\ H_n(Y, B; G_2) & \xrightarrow{\partial_*} & H_{n-1}(B; G_2) \end{array}$$

The induced homomorphism $h_{\#}$ is important in the further development of homology theory. As an example, we give the following application. Let R be an arbitrary ring, and assume that the abelian group G is also a left R -module, i.e., R operates on the left on G as a set of endomorphisms, satisfying the usual conditions. Any element $r \in R$ defines an endomorphism $G \rightarrow G$ by the rule $x \rightarrow rx$ for $x \in G$. There is an induced endomorphism of $H_n(X, X; G)$ according to the procedure developed in the preceding paragraphs. Thus, for each element $r \in R$ we have defined an endomorphism of $H_n(X, A; G)$. We leave it to the reader to verify that these induced endomorphisms define on $H_n(X, A; G)$ a structure of left R -module. The naturality properties (a) and (b) above show that f_* and ∂_* , respectively, are homomorphisms of left R -modules.

An especially important case occurs when R is a commutative field and G is a vector space over R . Then $H_n(X, A; G)$ is also a vector space over R , and

the induced homomorphisms f_* and ∂_* are R -linear. In this case all the machinery of vector space theory and linear algebra can be applied to problems arising in homology theory, which is often a substantial advantage.

Next, suppose that

$$0 \rightarrow G' \xrightarrow{h} G \xrightarrow{k} G'' \rightarrow 0$$

is a short exact sequence of abelian groups. This gives rise to the following sequence of chain maps and chain complexes for any pair, (X, A) :

$$0 \longrightarrow C(X, A; G') \xrightarrow{1 \otimes h} C(X, A; G) \xrightarrow{1 \otimes k} C(X, A; G'') \longrightarrow 0.$$

We assert that *this sequence of chain complexes is exact*. This assertion is an easy consequence of the fact that $C(X, A)$ is a chain complex of free abelian groups. As a consequence, we get a corresponding long exact homology sequence:

$$\cdots \xrightarrow{\beta} H_n(X, A; G') \xrightarrow{h_*} H_n(X, A; G) \xrightarrow{k_*} H_n(X, A; G'') \xrightarrow{\beta} H_{n-1}(X, A; G') \xrightarrow{h_*} \cdots$$

The connecting homomorphism β of this exact sequence is called the *Bockstein operator* corresponding to the given short exact sequence of coefficient groups. As is so often the case, this label is a misnomer because this homomorphism was introduced by other mathematicians before Bockstein.

The reader should formulate and prove the naturality properties of the Bockstein operator *vis á vis* homomorphisms induced by continuous maps and the boundary homomorphism of the exact sequence of a pair (X, A) :

$$\begin{array}{ccc} H_n(X, A; G'') & \xrightarrow{\beta} & H_{n-1}(X, A; G') \\ \downarrow \partial_* & & \downarrow \partial_* \\ H_{n-1}(A; G'') & \xrightarrow{\beta} & H_{n-2}(A; G') \end{array}$$

Caution: The question as to whether or not this diagram is commutative is a bit subtle.

EXERCISES

- 5.1. Using the methods of §VIII.4, determine the homology groups of the real projective plane for the case where the coefficient group G is cyclic of order 2. Then determine the long exact homology sequence corresponding to the following short exact sequence of coefficient groups:

$$0 \rightarrow \mathbf{Z} \xrightarrow{h} \mathbf{Z} \xrightarrow{k} \mathbf{Z}_2 \rightarrow 0.$$

Here $h(n) = 2n$ for any $n \in \mathbf{Z}$.

The coefficient homomorphism and Bockstein operator are additional elements of structure on the homology groups of a space. The fact that

homomorphisms induced by continuous maps must commute with them places a definite limitation on such induced homomorphisms.

§6. The Universal Coefficient Theorem

We will next take up the relation between integral homology groups and homology groups with various coefficients.

Let $K = \{K_n, \partial_n\}$ be an arbitrary chain complex. There is a natural homomorphism

$$\alpha: H_n(K) \otimes G \rightarrow H_n(K \otimes G)$$

defined as follows. Let $u \in H_n(K)$ and $x \in G$. Choose a representative cycle $u' \in Z_n(K)$ for u . Then it is immediate that $u' \otimes x \in K_n \otimes G$ is a cycle; define $\alpha(u \otimes x)$ to be the homology class of $u' \otimes x$. Of course it must be verified that this definition is independent of the choice of u' , and that α is a homomorphism.

As usual, α is natural in several different senses:

(a) If $f: K \rightarrow K'$ is a chain map, then the following diagram is commutative:

$$\begin{array}{ccc} H_n(K) \otimes G & \xrightarrow{\alpha} & H_n(K \otimes G) \\ \downarrow f_* \otimes 1_G & & \downarrow (f \otimes 1_G)_* \\ H_n(K') \otimes G & \xrightarrow{\alpha'} & H_n(K' \otimes G) \end{array}$$

(b) If $E: 0 \rightarrow K' \rightarrow K \rightarrow K'' \rightarrow 0$ is a split exact sequence of chain complexes, then the following diagram is commutative:

$$\begin{array}{ccc} H_n(K'') \otimes G & \xrightarrow{\alpha''} & H_n(K'' \otimes G) \\ \downarrow \partial_E \otimes 1_G & & \downarrow \partial_{E \otimes G} \\ H_{n-1}(K') \otimes G & \xrightarrow{\alpha'} & H_{n-1}(K' \otimes G) \end{array}$$

(Note: The fact that E is split exact assures exactness on tensoring with G .)

(c) If $h: G_1 \rightarrow G_2$ is a homomorphism of coefficient groups, then the following diagram is commutative:

$$\begin{array}{ccc} H_n(K) \otimes G_1 & \xrightarrow{\alpha_1} & H_n(K \otimes G_1) \\ \downarrow 1 \otimes h & & \downarrow h_* \\ H_n(K) \otimes G_2 & \xrightarrow{\alpha_2} & H_n(K \otimes G_2) \end{array}$$

If $0 \rightarrow G' \rightarrow G \rightarrow G'' \rightarrow 0$ is a short exact sequence of abelian groups, and K is a chain complex of *free* abelian groups, then we might expect a commutative diagram involving the Bockstein operator, but such does not exist.

For our purposes, the most important case of the homomorphism is where $K = C(X, A)$; then we obtain a homomorphism

$$\alpha : H_n(X, A) \otimes G \rightarrow H_n(X, A; G)$$

with all the above naturality properties.

Lemma 6.1. *If G is a free abelian group, then the homomorphism $\alpha : H_n(K) \otimes G \rightarrow H_n(K \otimes G)$ is an isomorphism.*

PROOF. First, one considers the case where $G = \mathbf{Z}$, which is trivial. In the general case, G is a direct sum of infinite cyclic groups, and α obviously “respects” such direct sum decompositions [because of property (c) above].

Q.E.D.

In order to make further progress, we must make use of the Tor functor (the first derived functor of the tensor product). For any two abelian groups A and B , we will use the notation $\text{Tor}(A, B)$ to denote $\text{Tor}_1^{\mathbf{Z}}(A, B)$. The definition and properties of this functor are given in most books on homological algebra, e.g., Cartan and Eilenberg [1], Hilton and Stammach [2], or Mac Lane [3]. Here is a list of some of the principal properties of this function:

- (1) (Symmetry) $\text{Tor}(A, B)$ and $\text{Tor}(B, A)$ are naturally isomorphic.
- (2) If either A or B is torsion-free, then $\text{Tor}(A, B) = 0$.
- (3) Let $0 \rightarrow F_1 \xrightarrow{h} F_0 \xrightarrow{k} A \rightarrow 0$ be a short exact sequence with F_0 a free abelian group; it follows that F_1 is also free. Then there is an exact sequence, as follows:

$$0 \longrightarrow \text{Tor}(A, B) \longrightarrow F_1 \otimes B \xrightarrow{h \otimes 1} F_0 \otimes B \xrightarrow{k \otimes 1} A \otimes B \longrightarrow 0.$$

Since any abelian group A is the homomorphic image of some free abelian group F_0 , we can use this property to define $\text{Tor}(A, B)$, or to determine it in specific cases.

- (4) For any abelian group G , $\text{Tor}(\mathbf{Z}_n, G)$ is isomorphic to the subgroup of G consisting of all $x \in G$ such that $nx = 0$ [this may be proved by use of (3)]. In particular, $\text{Tor}(\mathbf{Z}_n, \mathbf{Z}_m)$ is a cyclic group whose order is the g.c.d. of m and n .

- (5) Tor is an additive functor in each variable, i.e., for direct sums

$$\text{Tor}\left(\sum_i A_i, B\right) \approx \sum_i \text{Tor}(A_i, B).$$

- (6) Let $0 \rightarrow A' \xrightarrow{h} A \xrightarrow{k} A'' \rightarrow 0$ be a short exact sequence of abelian groups; then we have the following long exact sequence:

$$\begin{array}{ccccccc} 0 & \longrightarrow & \text{Tor}(A', B) & \xrightarrow{\text{Tor}(h, 1)} & \text{Tor}(A, B) & \xrightarrow{\text{Tor}(k, 1)} & \text{Tor}(A'', B) \\ & & \longrightarrow & & \longrightarrow & & \longrightarrow 0 \\ & & & & A' \otimes B & \xrightarrow{h \otimes 1} & A \otimes B & \xrightarrow{k \otimes 1} & A'' \otimes B & \longrightarrow & 0 \end{array}$$

[this is a generalization of (3)].

With these preliminaries out of the way, we can state and prove the universal coefficient theorem:

Theorem 6.2. *Let K be a chain complex of free abelian groups, and let G be an arbitrary abelian group. Then there exists a split short exact sequence*

$$0 \rightarrow H_n(K) \otimes G \xrightarrow{\alpha} H_n(K \otimes G) \xrightarrow{\beta} \text{Tor}(H_{n-1}(K), G) \rightarrow 0.$$

The homomorphism β is natural vis a vis chain maps and coefficient homomorphisms. The splitting is natural vis a vis coefficient homomorphisms, but it is not natural with respect to chain mappings.

PROOF. As mentioned in (3) above, we may choose a free abelian group F_0 such that there is an epimorphism $k: F_0 \rightarrow G$; let F_1 denote the kernel of k . Then F_1 is free, and we have the following short exact sequence:

$$0 \rightarrow F_1 \xrightarrow{h} F_0 \xrightarrow{k} G \rightarrow 0.$$

Now consider the following commutative diagram:

$$\begin{array}{ccccccc} H_n(K \otimes F_1) & \xrightarrow{h_{\#}} & H_n(K \otimes F_0) & \xrightarrow{k_{\#}} & H_n(K \otimes G) & \xrightarrow{\beta_0} & H_{n-1}(K \otimes F_1) \\ \uparrow \alpha_1 & & \uparrow \alpha_0 & & \uparrow \alpha & & \\ H_n(K) \otimes F_1 & \xrightarrow{1 \otimes h} & H_n(K) \otimes F_0 & \xrightarrow{1 \otimes k} & H_n(K) \otimes G & \longrightarrow & 0 \end{array}$$

The top line is part of the long exact sequence corresponding to the given short exact sequence of coefficients, with Bockstein operator β_0 . The bottom line is exact, and both α_0 and α_1 are isomorphisms by Lemma 6.1. From this diagram it readily follows that α is a monomorphism, and $\text{image } \alpha = \text{image } k_{\#} = \text{kernel } \beta_0$.

Next, consider the following somewhat analogous diagram:

$$\begin{array}{ccccccc} 0 \rightarrow \text{Tor}(H_{n-1}(K), G) & \longrightarrow & H_{n-1}(K) \otimes F_1 & \xrightarrow{1 \otimes h} & H_{n-1}(K) \otimes F_0 & \xrightarrow{1 \otimes k} & H_{n-1}(K) \otimes G \longrightarrow 0 \\ & & \downarrow \alpha_1 & & \downarrow \alpha_0 & & \downarrow \alpha \\ \boxed{1} & & & & & & \\ H_n(K \otimes G) & \xrightarrow{\beta_0} & H_{n-1}(K \otimes F_1) & \xrightarrow{h_{\#}} & H_{n-1}(K \otimes F_0) & \xrightarrow{k_{\#}} & H_{n-1}(K \otimes G). \end{array}$$

The top line of this diagram is the exact sequence mentioned in property (3) above. Once again, α_1 and α_0 are isomorphisms, and the diagram is commutative. It follows easily from this diagram that there exists a unique homomorphism

$$\beta: H_n(K \otimes G) \rightarrow \text{Tor}(H_{n-1}(K), G)$$

which makes the left-hand square (labeled 1) of this diagram commutative. Furthermore, β is an epimorphism, and $\text{kernel } \beta = \text{kernel } \beta_0$.

Thus, we have defined the homomorphism β , and proved the exactness of

the sequence mentioned in the theorem. We leave it to the reader to prove that β is natural vis a vis chain maps and coefficient homomorphisms. It remains to prove that the sequence splits. For this purpose, we will use the following trick. We may consider the sequence of abelian groups $\{H_n(K)\}$ as a chain complex with $\partial_n = 0$ for all n ; we will denote this chain complex by $H(K)$. With this notation, it is clear that $H_n(H(K)) = H_n(K)$. We assert that there exists a chain map $f : K \rightarrow H(K)$ such that the induced homomorphism $f_* : H_n(K) \rightarrow H_n(H(K))$ is the identity map of $H_n(K)$ onto itself. To prove this assertion, note that our hypothesis that K_n is a free abelian group for each n implies that $Z_n(K)$ is a direct summand of K_n . Hence, we may choose a direct sum decomposition

$$K_n = Z_n(K) \oplus L_n$$

for each n . Define $f_n : K_n \rightarrow H_n(K)$ by $f_n|_{Z_n(K)} =$ natural homomorphisms of $Z_n(K)$ onto $H_n(K)$, and $f_n|_{L_n} = 0$. It is readily verified that the sequence of homomorphisms $f = \{f_n\}$ is a chain map with the required properties. The definition of f obviously depends on the choice of the direct sum decomposition.

Next, by the naturality of α , we have the following commutative diagram:

$$\begin{array}{ccc} H_n(K) \otimes G & \xrightarrow{\alpha} & H_n(K \otimes G) \\ \downarrow f_* \otimes 1_G & & \downarrow (f \otimes 1_G)_* \\ H_n(H(K)) \otimes G & \xrightarrow{\alpha'} & H_n(H(K) \otimes G) \end{array}$$

However, it is readily checked that $H_n(H(K)) \otimes G = H_n(K) \otimes G = H_n(H(K) \otimes G)$ and that $f_* \otimes 1_G$ and α' are both the identity maps. Hence, it follows from the commutativity of the diagram that image α is a direct summand of $H_n(K \otimes G)$, as required. Incidentally, this furnishes an alternative proof that α is a monomorphism.

Using this procedure, it is easy to prove that the direct sum decomposition is natural vis a vis coefficient homomorphisms. Q.E.D.

We will give an example later to prove that it is impossible to choose the direct sum decomposition so it is natural with respect to chain maps.

Corollary 6.3. *For any pair (X, A) and any abelian group G there exists a split short exact sequence:*

$$0 \rightarrow H_n(X, A) \otimes G \xrightarrow{\alpha} H_n(X, A; G) \xrightarrow{\beta} \text{Tor}(H_{n-1}(X, A), G) \rightarrow 0.$$

The homomorphism α and β are natural with respect to homomorphisms induced by continuous maps of pairs and coefficient homomorphisms. The splitting can be chosen to be natural with respect to coefficient homomorphisms, but not with respect to homomorphisms induced by continuous maps.

These results show that the structure of the homology group $H_n(X, A; G)$ is *completely* determined by the structure of the integral homology groups $H_n(X, A)$ and $H_{n-1}(X, A)$. However, this does *not* imply that the homomorphism $f_* : H_n(X, A; G) \rightarrow H_n(Y, B; G)$ is determined by the homomorphisms $f_* : H_n(X, A) \rightarrow H_n(Y, B)$ and $f_* : H_{n-1}(X, A) \rightarrow H_{n-1}(Y, B)$ [here $f : (X, A) \rightarrow (Y, B)$ denotes a continuous map of pairs]. A convincing example will be given later.

EXERCISES

6.1. Decide whether or not the following diagram is commutative for any pair (X, A) and any abelian group G :

$$\begin{CD} H_n(X, A; G) @>\beta>> \text{Tor}(H_{n-1}(X, A), G) \\ @VV\partial_*V @VV\text{Tor}(\partial_*, 1_G)V \\ H_{n-1}(A; G) @>\beta>> \text{Tor}(H_{n-2}(A), G) \end{CD}$$

6.2. Prove that $\alpha : H_i(X, A) \otimes G \rightarrow H_i(X, A; G)$ is an isomorphism for any pair (X, A) and any group G for $i = 0$ or 1 .

6.3. Let X be a finite regular graph. Express the structure of the homology groups $H_q(X; G)$ in terms of the Euler characteristic and number of components of X .

6.4. Describe the structure of the homology groups $H_q(X; G)$ for any group G in the following cases:

- (a) $X = S^n$.
- (b) X is a compact orientable 2-manifold.
- (c) X is a compact nonorientable 2-manifold.

6.5. Let X be an n -dimensional pseudomanifold in the sense of §IX.8. Determine the structure of $H_n(X, G)$ in case X is (a) orientable and (b) nonorientable.

We will conclude that section by giving another proof of the excision property for homology with arbitrary coefficient groups. Let (X, A) be a pair, and W a subset of A such that \overline{W} is contained in the interior of A . Then the inclusion map $i : (X - W, A - W) \rightarrow (X, A)$ induces a chain map

$$i_{\#} : C(X - W, A - W) \rightarrow C(X, A).$$

It is easy to verify that $i_{\#}$ is a monomorphism; thus, we can consider $C(X - W, A - W)$ as a subcomplex of $C(X, A)$. Hence, we have the following short exact sequence of chain complexes:

$$0 \rightarrow C(X - W, A - W) \xrightarrow{i_{\#}} C(X, A) \rightarrow \frac{C(X, A)}{C(X - W, A - W)} \rightarrow 0.$$

This short exact sequence of chain complexes gives rise to a long exact homology sequence, as usual. Because the excision property is true for integral

homology, we can conclude that

$$H_n\left(\frac{C(X, A)}{C(X - W, A - W)}\right) = 0$$

for all n . Next, one must verify that the quotient complex

$$\frac{C(X, A)}{C(X - W, A - W)}$$

is a chain complex of free abelian groups, and that the short exact sequence above is split exact. This is not difficult and is left to the reader. One now completes the proof by tensoring the short exact sequence with G and considering the resulting long exact homology sequence. By using Theorem 6.2, one proves that

$$H_n\left(\frac{C(X, A)}{C(X - W, A - W)} \otimes G\right) = 0$$

for all n . It follows from exactness that

$$i_* : H_n(X - W, A - W; G) \rightarrow H_n(X, A; G)$$

is an isomorphism for all n , as desired.

This technique can also be used to prove that the chain map

$$\sigma \otimes 1_G : C(X, A; \mathcal{U}) \otimes G \rightarrow C(X, A) \otimes G$$

induces isomorphisms in homology in all dimensions (here \mathcal{U} is a generalized open covering of X).

§7. Further Properties of Homology with Arbitrary Coefficients

Practically all the properties we have proved for integral homology have analogs for homology with arbitrary coefficients. For example, the reader should have no difficulty verifying that Proposition VIII.6.1 is true for homology with coefficients in any group G .

The material in Chapter IX on the homology of CW-complexes readily generalizes to the case of an arbitrary coefficient group. We will quickly indicate how this goes.

Let $K = \{K^n\}$ be a CW-complex on the space X . Using the universal coefficient theorem (Corollary 6.3) it is readily shown that $H_q(K^n, K^{n-1}; G) = 0$ for $q \neq n$, and that

$$\alpha : H_n(K^n, K^{n-1}) \otimes G \rightarrow H_n(K^n, K^{n-1}; G)$$

is an isomorphism. Thus, if we define

$$C_n(K; G) = H_n(K^n, K^{n-1}; G),$$

then

$$C_n(K; G) = C_n(K) \otimes G.$$

Next, we define a boundary operator $C_n(K; G) \rightarrow C_{n-1}(K; G)$ as the composition of the homomorphisms

$$H_n(K^n, K^{n-1}; G) \xrightarrow{\partial_*} H_{n-1}(K^{n-1}; G) \xrightarrow{j_{n-1}} H_{n-1}(K^{n-1}, K^{n-2}; G)$$

by analogy with that defined in §IX.4. It is then true that this boundary operator is $d_n \otimes 1_G$, where $d_n: C_n(K) \rightarrow C_{n-1}(K)$ is defined in §IX.4. In other words,

$$C(K; G) = C(K) \otimes G.$$

One can now prove an analog of Theorem IX.4.2 for the case of an arbitrary coefficient group G . Essentially this analog says that $H_n(X; G)$ is naturally isomorphic to $H_n(C(K; G))$. Similarly, there is an analog of Theorem IX.4.5 for homomorphisms induced by cellular maps: Assume $K = \{K^n\}$ is a CW-complex on X , $L = \{L^n\}$ is a CW-complex on Y , and $f: X \rightarrow Y$ is a cellular map, i.e., $f(K^n) \subset L^n$. Then f induces a chain map $\varphi: C(K) \rightarrow C(L)$, and we have a commutative diagram:

$$\begin{array}{ccc} H_n(X; G) \approx & H_n(C(K) \otimes G) & \\ \downarrow f_* & & \downarrow (\varphi \otimes 1_G)_* \\ H_n(Y; G) \approx & H_n(C(L) \otimes G) & \end{array}$$

These results can be summarized as follows: To extend the results of §IX.4 from integral homology to homology with arbitrary coefficient group G , simply tensor all chain complexes and chain maps with G . In particular, this applies to the computation of the homology of regular CW-complexes as described in §IX.7.

There is one case where the computation of the homology of regular cell complexes becomes *greatly* simplified, namely, the case where $G = \mathbf{Z}_2$. In this case every incidence number must be 0 or 1, and we see that $[e^n: e^{n-1}] = 1$ or 0 according as e^{n-1} is or is not a face of e^n . Thus, the four rules given in Theorem IX.7.2 for determining incidence numbers reduce to two rules, and it is not necessary to use an inductive procedure. Of course, mod 2 homology ignores much of the structure of integral homology, but for some problems it is more appropriate than integral homology.

Examples

7.1. Let P^2 denote the real projective plane. In VIII.4 we found that the only nonzero homology groups of P^2 were

$$\begin{aligned} H_0(P^2) &= \mathbf{Z}, \\ H_1(P^2) &= \mathbf{Z}_2. \end{aligned}$$

Thus, if $f : P^2 \rightarrow S^2$ is any continuous map, then

$$f_* : H_0(P^2) \rightarrow H_0(S^2)$$

is an isomorphism (both are connected spaces), whereas for $q \neq 0$,

$$f_* : H_q(P^2) \rightarrow H_q(S^2)$$

must be the zero map. Hence, there is no possibility of distinguishing between different homotopy classes of such maps using integral homology. We will now show that one *can* distinguish two different homotopy classes using mod 2 homology. To prove this, recall that there is a CW-complex, K , on P^2 having a single cell in dimensions 0, 1, and 2; this was used to compute the homology of P^2 in Example VIII.4.3, although it was not called a CW-complex at that time. Thus, $C_0(K)$, $C_1(K)$, and $C_2(K)$ are infinite cyclic groups,

$$d_2 : C_2(K) \rightarrow C_1(K)$$

has degree ± 2 , and

$$d_1 : C_1(K) \rightarrow C_0(K)$$

has degree 0. Analogously, there is a CW-complex L on S^2 having a single vertex, a single 2-cell, and no 1-cells. There is an obvious cellular group

$$f : P^2 \rightarrow S^2$$

defined by shrinking the 1-skeleton, K^1 , to a point, namely, L^0 . The open 2-cell of K is mapped homomorphically onto the open 2-cell of L . We wish to compute the induced homomorphism on mod 2 homology. To this end, we determine the chain transformation

$$f' : C(K) \rightarrow C(L)$$

induced by the cellular group f . The only nontrivial problem is to determine the homomorphism $C_2(K) \rightarrow C_2(L)$. But this is easily settled by Theorem IX.2.1 Let $g : (E^2, S^1) \rightarrow (K^2, K^1)$ be the characteristic map for the unique 2-cell of K . In view of the way the map $f : P^2 \rightarrow S^2$ was defined, it is clear that

$$h = fg : (E^2, S^1) \rightarrow (L^2, L^1)$$

is a characteristic map for the only 2-cell of L . Thus, we have the following commutative diagram:

$$\begin{array}{ccc} (E^2, S^1) & \xrightarrow{g} & (K^2, K^1) \\ & \searrow h & \downarrow f \\ & & (L^2, L^1) \end{array}$$

Hence, we have the following commutative diagram:

$$\begin{array}{ccc}
 H_2(E^2, S^1) & \xrightarrow{g_*} & H_2(K^2, K^1) \\
 & \searrow h_* & \downarrow f_* \\
 & & H_2(L^2, L^1)
 \end{array}$$

By Theorem IX.2.1, g_* and h_* are isomorphisms; it follows that f_* is also an isomorphism. Therefore, the chain map $f' : C(K) \rightarrow C(L)$ is completely determined. All that remains is to tensor with \mathbf{Z}_2 and then pass to homology. The end result is that

$$f_* : H_2(P^2; \mathbf{Z}_2) \rightarrow H_2(S^2; \mathbf{Z}_2)$$

is an isomorphism. On the other hand, if $\varphi : P^2 \rightarrow S^2$ is the constant map, then

$$\varphi_* : H_2(P^2, \mathbf{Z}_2) \rightarrow H_2(S^2, \mathbf{Z}_2)$$

is the 0 homomorphism. Thus, f and φ are not homotopic.

Note that f and φ must (of necessity) induce the same homomorphism on integral homology groups. This proves our earlier assertion that the induced homomorphisms on integral homology groups do not suffice to determine the induced homomorphisms on homology groups with other coefficients

Finally, this example also shows that the splitting of the short exact sequence of the universal coefficient theorem (Corollary 6.3) *cannot* be chosen to be natural. Consider the following commutative diagram involving the universal coefficient theorems for $H_2(P^2, \mathbf{Z}_2)$ and $H_2(S^2, \mathbf{Z}_2)$ and the homomorphism induced by the map $f : P^2 \rightarrow S^2$ described above:

$$\begin{array}{ccccccc}
 0 & \longrightarrow & H_2(P^2) \otimes \mathbf{Z}_2 & \xrightarrow{\alpha_1} & H_2(P^2, \mathbf{Z}_2) & \xrightarrow{\beta_1} & \text{Tor}(H_1(P^2), \mathbf{Z}_2) \longrightarrow 0 \\
 & & \downarrow f_* \otimes 1 & & \downarrow f_* & & \downarrow \text{Tor}(f_*, 1) \\
 0 & \longrightarrow & H_2(S^2) \otimes \mathbf{Z}_2 & \xrightarrow{\alpha_2} & H_2(S^2, \mathbf{Z}_2) & \xrightarrow{\beta_2} & \text{Tor}(H_1(S^2), \mathbf{Z}_2) \longrightarrow 0
 \end{array}$$

In the top line, $H_2(P^2) \otimes \mathbf{Z}_2 = 0$ and β_1 is an isomorphism. In the bottom line, $\text{Tor}(H_1(S^2), \mathbf{Z}_2) = 0$ and α_2 is an isomorphism. As we have just proved, the vertical arrow labeled f_* is an isomorphism; however, this fact contradicts the possibility of any splitting of these two short exact sequences which is natural with respect to homomorphisms induced by continuous maps.

We will conclude this section with a brief consideration of the mod 2 homology of a nonorientable pseudomanifold.

Let K be an n -dimensional nonorientable pseudomanifold; by Theorem IX.8.2, $H_n(K) = 0$. For some purposes, this is a defect in the theory; we need a nonzero homology class in the top dimension. This matter is partially remedied by using mod 2 homology. Indeed we find that $H_n(K, \mathbf{Z}_2) = \mathbf{Z}_2$ (use the universal coefficient theorem and Theorems IX.8.2 and IX.8.3). A repre-

sentative cycle for the nonzero element of $H_n(K, \mathbf{Z}_2)$ is obtained by taking the sum of all the n -cells of K . Since we are using \mathbf{Z}_2 as coefficient group, we do not need to worry about orientations.

References

1. H. Cartan and S. Eilenberg, *Homological Algebra*, Princeton University Press, Princeton, N.J., 1956, Chapter VI, §1.
2. P. Hilton and U. Stammach, *A Course in Homological Algebra*, Springer-Verlag, New York, 1971, pp. 112–115.
3. S. Mac Lane, *Homology*, Springer-Verlag, New York, 1963, Chapter V, §6.

CHAPTER XI

The Homology of Product Spaces

§1. Introduction

If two or more spaces are related to each other in some way, we would naturally expect that their homology groups should also be related in some way. Some of the most important theorems in the preceding chapters bear out this expectation: If A is a subspace of X , the exact homology sequence of the pair (X, A) describes the relations between the homology groups of A and the homology groups of X . If the space X is the union of two subspaces U and V , then the Mayer–Vietoris sequence gives relations between the homology groups of U , V , $U \cap V$, and X .

The main theorems of this chapter are of this same general nature. The Eilenberg–Zilber theorem asserts that the singular chain complex of the product of two spaces, $C(X \times Y)$, is chain homotopy equivalent to the tensor product of the chain complexes of the two factors denoted by $C(X) \otimes C(Y)$. The Künneth theorem expresses the homology groups of the product space $X \times Y$ in terms of the homology groups of X and the homology groups of Y . The derivation of the Künneth theorem from the Eilenberg–Zilber theorem is purely algebraic.

These theorems are somewhat more complicated than most of our previous theorems, such as the exactness of the Mayer–Vietoris sequence. Nevertheless, they are of basic importance in homology theory.

The material on CW-complexes in §2 is not essential for most of the rest of the chapter. It is introduced mainly to motivate the definition of the tensor product of chain complexes.

§2. The Product of CW-Complexes and the Tensor Product of Chain Complexes

Let $K = \{K^n\}$ be a CW-complex on the space X , and $L = \{L^n\}$ a CW-complex on the space Y . We wish to prove that $X \times Y$ is a CW-complex in a natural way. In order to understand this situation better, we need the following basic facts about open and closed cells; our notation is that of §IX.2.

(a) $E^m \times E^n$ is homeomorphic to E^{m+n} ; under any such homeomorphism, $(E^m \times S^{n-1}) \cup (S^{m-1} \times E^n)$ corresponds to the boundary S^{m+n-1} .

(b) $U^m \times U^n$ is homeomorphic to U^{m+n} .

In view of statement (b), it is natural to demand that an open cell of a CW-complex on $X \times Y$ should be the product of an open cell of K with an open cell of L . Therefore, we *define* the n -skeleton of a CW-structure on $X \times Y$ by

$$M^n = \bigcup_{p+q=n} K^p \times L^q$$

for $n = 0, 1, 2, \dots$. Then the subsets $M^n \subset X \times Y$ are closed, $M^n \subset M^{n+1}$ for all $n \geq 0$, M^0 is discrete (because it is the product of discrete spaces) and

$$X \times Y = \bigcup_{n=0}^{\infty} M^n.$$

If e^m is an m -cell of K with characteristic map $f: E^m \rightarrow \bar{e}^m$, and if e^n is an n -cell of L with characteristic map $g: E^n \rightarrow \bar{e}^n$, then $f \times g: E^m \times E^n \rightarrow \bar{e}^m \times \bar{e}^n$ has all the required properties for a characteristic map of the product cell $e^m \times e^n$. Thus, it only remains to check that the product topology on $X \times Y$ is the same as the weak topology determined by the closed cells. If both K and L are *finite* CW-complexes, then M will also have only a finite number of cells, and there is nothing to prove. J. H. C. Whitehead proved that if one of the factors is locally compact then the product topology agrees with the weak topology. However, Dowker gave an example to show that in the general case, the two topologies on $X \times Y$ do *not* agree. See Lundell and Weingram [5] for details. Fortunately, there is an easy way out of this difficulty; one can agree to give $X \times Y$ the weak topology, so that it is a CW-complex. The weak topology will be *larger* than the product topology in general [i.e., it will have more open (or closed) sets], but the *compact* sets will be the same in both topologies. Therefore, the identity map,

$$X \times Y_{(\text{weak top.})} \rightarrow X \times Y_{(\text{prod. top.})},$$

is a continuous map and induces an isomorphism on singular homology groups. See N. E. Steenrod [8] for details.

However, we do not want to get involved with these fine points now. The reader can restrict his attention to finite CW-complexes, knowing full well that the generalization to infinite CW-complexes is not difficult.

Next, let us assume that K and L are regular CW-complexes. Then it is readily seen that $M = \{M^n\}$ (as defined above) is a *regular* CW-complex on $X \times Y$ (provided $X \times Y$ is given the weak topology). As usual, there are many choices for orientations of the cells of $X \times Y$, and hence of incidence numbers. Let us assume that orientations (and hence incidence numbers) have been chosen for the cells of K and L . It seems plausible to expect that there should be a way to use these chosen orientations of the cells of K and L to define *canonical* orientations of the cells of M . The following theorem shows that this expectation is justified. The actual result is stated in terms of incidence numbers rather than orientations. However, this does not matter from a logical point of view, since there is a 1–1 correspondence between incidence numbers and orientations of cells in any regular CW-complex.

Theorem 2.1. *Let K be a regular CW-complex on X with cells e_i^m , and let L be a regular CW-complex on Y with cells σ_j^n . Assume that the incidence numbers have been chosen for both K and L . Then incidence numbers are defined for the product cells on $X \times Y$ by the following rules:*

$$[e^m \times \sigma^n : e^{m-1} \times \sigma^n] = [e^m : e^{m-1}]$$

$$[e^m \times \sigma^n : e^m \times \sigma^{n-1}] = (-1)^m [\sigma^n : \sigma^{n-1}]$$

$$[e_i^m \times \sigma_j^n : e_k^p \times \sigma_l^q] = 0 \text{ if } e_i^m \neq e_k^p \text{ and } \sigma_j^n \neq \sigma_l^q$$

To prove this theorem, we must verify that statements (1)–(4) of Theorem IX.7.2 are true with the stated choices of incidence numbers. This we leave to the reader as a nontrivial exercise.

Obviously one could establish other conventions for the incidence numbers of a product complex, but the one given by this theorem is universally accepted.

Now let us consider the group of n -chains, $C_n(M)$ of the regular CW-complex M on $X \times Y$. It has as basis the oriented product cells $e_i^p \times \sigma_j^q$, $p + q = n$. This suggests that we should identify $C_n(M)$ with the direct sum of tensor products,

$$\sum_{p+q=n} C_p(K) \otimes C_q(L).$$

Using the formulas for incidence numbers in the theorem, we see that

$$\partial(e_i^p \times \sigma_j^q) = (\partial e_i^p) \times \sigma_j^q + (-1)^p e_i^p \times (\partial \sigma_j^q),$$

where the right-hand side of this equation is to be interpreted in an obvious way. Since this formula holds true for the basis elements, we can extend it of linear combinations of the basis elements, obtaining the formula

$$\partial(u \otimes v) = (\partial u) \otimes v + (-1)^p u \otimes (\partial v)$$

for any $u \in C_p(K)$ and $v \in C_q(L)$.

This suggests the following definition.

Definition 2.2. Let $C' = \{C'_n, \partial'_n\}$ and $C'' = \{C''_n, \partial''_n\}$ be chain complexes. Their *tensor product* $C = C' \otimes C''$ is the chain complex defined as follows: The groups are

$$C_n = \sum_{p+q=n} C'_p \otimes C''_q,$$

and the homomorphisms $\partial_n : C_n \rightarrow C_{n-1}$ are defined by

$$\partial_n(u \otimes v) = (\partial'_p u) \otimes v + (-1)^p u \otimes (\partial''_q v)$$

for any $u \in C'_p, v \in C''_q, p + q = n$.

Of course, one must verify that $\partial_{n-1} \partial_n = 0$.

In view of this definition, we can assert that *the chain complex $C(M)$ is isomorphic to $C(K) \otimes C(L)$, where $K, L,$ and M are regular CW-complexes on $X, Y,$ and $X \times Y$, as described above.* Of course, it remains to determine the relation between the homology groups of the tensor product of two chain complexes and the homology of each of the factors. We will describe the solution to this problem in §4. This result shows that the algebraic operation of taking the tensor product of chain complexes corresponds to the topological operation of taking the cartesian product of two spaces. Soon we will see another example of this process.

EXERCISES

- 2.1. Let K and L be *finite* CW-complexes on X and Y , respectively. What is the relation between the Euler characteristic of $X, Y,$ and $X \times Y$?
- 2.2. Let K and L be *regular* CW-complexes on X and Y , respectively. Assume that orientations and incidence numbers have been chosen for the cells of K and L . Consider the canonical homeomorphism $f : X \times Y \rightarrow Y \times X$ defined by $f(x, y) = (y, x)$. Then f maps the oriented cell $e^m \times \sigma^n$ homeomorphically onto $\sigma^n \times e^m$ and induces an isomorphism

$$f_* : H_{m+n}[\overline{e^m \times \sigma^n}, (e^m \times \sigma^n)] \rightarrow H_{m+n}[\overline{\sigma^n \times e^m}, (\sigma^n \times e^m)].$$

Show that $f_*(e^m \times \sigma^n) = (-1)^{mn} \sigma^n \times e^m$. (HINT: Use induction on the dimension of the cell.)

§3. The Singular Chain Complex of a Product Space

Our immediate objective is to define a natural chain map

$$\zeta : C(X) \otimes C(Y) \rightarrow C(X \times Y)$$

for any topological spaces X and Y . Then later we will show that ζ induces an isomorphism of homology groups. The definition of ζ is very simple; however, the proof that the induced homomorphism on homology groups is an isomorphism will be somewhat more involved.

It will be convenient to use the following notation, which is now standard: If $f: A \rightarrow B$ and $g: C \rightarrow D$ are continuous maps, then $f \times g: A \times C \rightarrow B \times D$ denotes the map defined by $(f \times g)(a, c) = (fa, gc)$. We will also find it convenient to identify $I^m \times I^n$ with I^{m+n} in the obvious way. With these conventions, if $S: I^m \rightarrow X$ and $T: I^n \rightarrow Y$ are singular cubes in X and Y , respectively, then $S \times T: I^{m+n} \rightarrow X \times Y$ is a singular cube in the product space. Thus, we can define a homomorphism

$$\zeta_{m,n}: Q_m(X) \otimes Q_n(Y) \rightarrow Q_{m+n}(X \otimes Y)$$

by the formula

$$\zeta_{m,n}(S \otimes T) = S \times T.$$

We assert that the homomorphisms $\zeta_{m,n}$ for all values of m and n define a chain map

$$\zeta: Q(X) \otimes Q(Y) \rightarrow Q(X \times Y).$$

To verify that ζ is a chain map, one must compute $\partial(S \times T)$. This is not difficult if one uses the following formulas:

$$(A_i S) \times T = A_i(S \times T), \quad 1 \leq i \leq m,$$

$$(B_i S) \times T = B_i(S \times T), \quad 1 \leq i \leq m,$$

$$S \times (A_j T) = A_{m+j}(S \times T), \quad 1 \leq j \leq n,$$

$$S \times (B_j T) = B_{m+j}(S \times T), \quad 1 \leq j \leq n.$$

It is clear that if S or T is a degenerate singular cube, then so is $S \times T$. Hence,

$$\zeta_{m,n}(Q_m(X) \otimes D_n(Y)) \subset D_{m+n}(X \times Y),$$

$$\zeta_{m,n}(D_m(X) \otimes Q_n(Y)) \subset D_{m+n}(X \times Y)$$

and, therefore, $\zeta_{m,n}$ induces a homomorphism of quotient groups,

$$\zeta_{m,n}: C_m(X) \otimes C_n(Y) \rightarrow C_{m+n}(X \times Y)$$

and the homomorphisms $\zeta_{m,n}$ for m and n obviously define a chain map

$$\zeta: C(X) \otimes C(Y) \rightarrow C(X \times Y).$$

Next, we point out that the chain map ζ has the following very important naturality property: Let $f: X \rightarrow X'$ and $g: Y \rightarrow Y'$ be continuous maps. Then the following diagram is obviously commutative:

$$\begin{array}{ccc} Q_m(X) \otimes Q_n(Y) & \xrightarrow{\zeta_{m,n}} & Q_{m+n}(X \times Y) \\ \downarrow f_\# \otimes g_\# & & \downarrow (f \times g)_\# \\ Q_m(X') \otimes Q_n(Y') & \xrightarrow{\zeta_{m,n}} & Q_{m+n}(X' \times Y') \end{array}$$

Hence on passing to quotient groups, etc., we obtain the following commutative diagram:

$$\begin{array}{ccc}
C(X) \otimes C(Y) & \xrightarrow{\zeta} & C(X \times Y) \\
\downarrow f_* \otimes g_* & & \downarrow (f \times g)_* \\
C(X') \otimes C(Y') & \xrightarrow{\zeta} & C(X' \times Y')
\end{array}$$

Theorem 3.1 (Eilenberg–Zilber theorem. *The chain map $\zeta: C(X) \otimes C(Y) \rightarrow C(X \times Y)$ is a chain homotopy equivalence, and hence induces isomorphisms*

$$\zeta_* : H_q(C(X) \otimes C(Y)) \cong H_q(X \times Y).$$

We will postpone the proof of this theorem until later. For the time being, we point out that

$$\zeta_{0,0} : C_0(X) \otimes C_0(Y) \rightarrow C_0(X \times Y)$$

is an isomorphism for any spaces X and Y . However, in higher degrees, ζ is only a monomorphism, not an isomorphism.

§4. The Homology of the Tensor Product of Chain Complexes (The Künneth Theorem)

The preceding paragraphs should convince the reader of the importance of the following problem: *Let K and L be chain complexes. Is the homology of the tensor product, $K \otimes L$, determined by the homology of K and L ? If so, how?* The answer to the first question is affirmative. We will now proceed to describe the details. First of all, there is a natural homomorphism

$$\alpha : H_m(K) \otimes H_n(L) \rightarrow H_{m+n}(K \otimes L)$$

which is defined as follows. Let $u \in H_m(K)$ and $v \in H_n(L)$; choose representative cycles $u' \in Z_m(K)$ for u and $v' \in Z_n(L)$ for v . It is immediate that $u' \otimes v' \in K_m \otimes L_n$ is a cycle; its homology class is, by definition, $\alpha(u \otimes v)$. Of course, it is necessary to check that this definition is independent of the choices of the cycles u' and v' , and that α is actually a homomorphism. The reader will note that this definition is a slight generalization of that given in §X.6.

The homomorphism α has various naturality properties. For example:

(a) If $f: K \rightarrow K'$ and $g: L \rightarrow L'$ are chain maps, then the following diagram is commutative:

$$\begin{array}{ccc}
H_m(K) \otimes H_n(L) & \xrightarrow{\alpha} & H_{m+n}(K \otimes L) \\
\downarrow f_* \otimes g_* & & \downarrow (f \times g)_* \\
H_m(K') \otimes H_n(L') & \xrightarrow{\alpha'} & H_{m+n}(K' \otimes L')
\end{array}$$

(b) Assume that

$$E : 0 \rightarrow K' \xrightarrow{i} K \xrightarrow{j} K'' \rightarrow 0$$

is a short exact sequence of chain complexes, and that L is a chain complex such that the following sequence is exact:

$$E \otimes L : 0 \longrightarrow K' \otimes L \xrightarrow{i \otimes 1} K \otimes L \xrightarrow{j \otimes 1} K'' \otimes L \longrightarrow 0$$

(sufficient conditions for $E \otimes L$ to be exact are that E be *split* exact, or that L be a chain complex of torsion-free abelian groups). Then the following diagram is commutative:

$$\begin{array}{ccc} H_m(K'') \otimes H_n(L) & \xrightarrow{\alpha} & H_{m+n}(K'' \otimes L) \\ \downarrow \partial_E \otimes 1 & & \downarrow \partial_{E \otimes L} \\ H_{m-1}(K') \otimes H_n(L) & \xrightarrow{\alpha} & H_{m+n-1}(K' \otimes L) \end{array}$$

(c) There is an obvious symmetric situation: Assume that

$$E : 0 \rightarrow L' \xrightarrow{i} L \xrightarrow{j} L'' \rightarrow 0$$

is a short exact sequence of chain complexes, and that K is a chain complex such that the sequence

$$K \otimes E : 0 \longrightarrow K \otimes L' \xrightarrow{1 \otimes i} K \otimes L \xrightarrow{1 \otimes j} K \otimes L'' \longrightarrow 0$$

is exact. The reader should investigate the question of the commutativity of the following diagram:

$$\begin{array}{ccc} H_m(K) \otimes H_n(L'') & \xrightarrow{\alpha} & H_{m+n}(K \otimes L'') \\ \downarrow 1 \otimes \partial_E & & \downarrow \partial_{K \otimes E} \\ H_m(K) \otimes H_{n-1}(L') & \xrightarrow{\alpha} & H_{m+n-1}(K \otimes L') \end{array}$$

With these preliminaries taken care of, we can now state our main theorem, the so-called Künneth theorem:

Theorem 4.1. *Let K and L be chain complexes, at least one of which consists of free abelian groups. Then there exists a split exact sequence:*

$$0 \rightarrow \sum_{i+j=n} H_i(K) \otimes H_j(L) \xrightarrow{\alpha} H_n(K \otimes L) \xrightarrow{\beta} \sum_{i+j=n-1} \text{Tor}(H_i(K), H_j(L)) \rightarrow 0.$$

The homomorphisms α and β are natural with respect to chain maps but the splitting is not natural.

The proof of this important theorem is not difficult; it may be found in various books on homological algebra and algebraic topology, e.g., Vick [9], Hilton and Stammach [4], Mac Lane [6], Cartan and Eilenberg [1], or Dold [2]. Actually, the theorem can be proved under slightly more general hy-

potheses than we have stated it, but we will have no use for such greater generality.

This theorem can be combined with our previous results on the product of regular CW-complexes and the singular chain complex of a product space to obtain significant results on the homology of product spaces. We will state the precise results later. In the meantime, we note the following corollary for future reference:

Corollary 4.2. *Suppose that K and L are chain complexes of free abelian groups which have the homology of a point, i.e.,*

$$H_q(K) = H_q(L) = 0 \quad \text{for } q \neq 0,$$

$$H_0(K) = H_0(L) = \mathbf{Z}.$$

Then $K \otimes L$ also has the homology of a point, and

$$\alpha : H_0(K) \otimes H_0(L) \rightarrow H_0(K \otimes L)$$

is an isomorphism.

§5. Proof of the Eilenberg–Zilber Theorem

We must define a chain map $\eta : C(X \times Y) \rightarrow C(X) \otimes C(Y)$ such that $\eta\zeta$ is chain homotopic to the identity map of $C(X) \otimes C(Y)$, and $\zeta\eta$ is chain homotopic to the identity map of $C(X \times Y)$. One way to proceed is by brute force, relying on our geometric intuitive to lead us to the correct formulas. We will indicate the first few steps in such a procedure, by defining homomorphisms

$$\eta_q : Q_q(X \times Y) \rightarrow \sum_{i+j=q} Q_i(X) \otimes Q_j(Y)$$

such that on passing to the quotient groups modulo degenerate singular chains we obtain the desired chain map η .

Note that a singular n -cube $I^n \rightarrow X \times Y$ in the product space corresponds in an obvious way to a pair of singular n -cubes $S : I^n \rightarrow X$ and $T : I^n \rightarrow Y$ in each of the factors. It will be convenient to let the notation (S, T) denote the corresponding singular n -cube in the product space $X \times Y$.

It is obvious that we should define $\eta_0 : Q_0(X \times Y) \rightarrow Q_0(X) \otimes Q_0(Y)$ by the formula

$$\eta_0(S, T) = S \otimes T$$

for any singular 0-cubes $S : I^0 \rightarrow X$ and $T : I^0 \rightarrow Y$. This makes η_0 the inverse of ζ_0 (which is an isomorphism).

Next, one defines $\eta_1 : Q_1(X \times Y) \rightarrow Q_0(X) \otimes Q_1(Y) + Q_1(X) \otimes Q_0(Y)$ by the formula

$$\eta_1(S, T) = (A_1 S) \otimes T + S \otimes (B_1 T)$$

for any singular 1-cubes $S : I^1 \rightarrow X$ and $T : I^1 \rightarrow Y$.

To define η_q in general, we need a generalization of the face operators A_i and B_i . Let H be any subset of $\{1, 2, \dots, n\}$, and let K denote the complementary subset. If H has p elements and K has q elements, $p + q = n$, we will let

$$\varphi_K : K \rightarrow \{1, 2, \dots, q\}$$

denote the unique bijective, order-preserving map. If $T : I^n \rightarrow X$ is any singular n -cube, let

$$A_H T, B_H T : I^q \rightarrow X$$

denote the following maps:

$$(A_H T)(x_1, \dots, x_q) = T(y_1, \dots, y_n),$$

where

$$y_i = \begin{cases} 0 & \text{if } i \in H \\ x_{\varphi_K(i)} & \text{if } i \in K, \end{cases}$$

and

$$(B_H T)(x_1, \dots, x_q) = T(y_1, \dots, y_n),$$

where

$$y_i = \begin{cases} 1 & \text{if } i \in H \\ x_{\varphi_K(i)} & \text{if } i \in K. \end{cases}$$

Examples

5.1. If $H = \emptyset$, then $A_H T = B_H T = T$.

5.2. If $H = \{i\}$, then $A_H T = A_i T$ and $B_H T = B_i T$.

5.3. If $H = \{1, 2, \dots, n\}$, then $A_H T$ and $B_H T$ are singular 0-cubes represented by $T(0, \dots, 0)$ and $T(1, \dots, 1)$, respectively.

We can now define $\eta_q : Q_q(X \times Y) \rightarrow \sum_{i+j=q} Q_i(X) \otimes Q_j(Y)$ by the magic formula

$$\eta_q(S, T) = \sum \rho_{H,K} A_H(S) \otimes B_K(T),$$

where $S : I^q \rightarrow X$ and $T : I^q \rightarrow Y$ are singular q -cubes, H ranges over all subsets of $\{1, 2, \dots, q\}$ and K denotes the complementary set, and $\rho_{H,K} = \pm 1$ denotes the signature of the permutation HK of $\{1, \dots, q\}$. (If H or K is empty, then $\rho_{H,K} = +1$.)

The student who has sufficient stamina and enthusiasm for calculating can now verify the following assertions:

(a) If (S, T) is a degenerate singular cube, then $\eta_q(S, T)$ belongs to $\sum_{i+j=q} [D_i(X) \otimes Q_j(Y) + Q_i(X) \otimes D_j(Y)]$. Hence, η_q induces a homomorphism

$$\eta_q : C_q(X \times Y) \rightarrow \sum_{i+j=q} C_i(X) \otimes C_j(Y).$$

(b) The sequence of homomorphisms $\eta = \{\eta_q\}$ is a chain map $C(X \times Y) \rightarrow C(X) \otimes C(Y)$.

(c) $\eta\zeta = \text{identity map of } C(X) \otimes C(Y)$.

(d) It is possible to define a chain homotopy between $\zeta\eta$ and the identity map of $C(X \times Y)$, but the formulas are somewhat complicated.

Rather than go through the details of these lengthy calculations, it seems preferable to use a more conceptual method due to Eilenberg and Mac Lane, called the *method of acyclic models*. This method makes strong use of the naturality of the chain maps ζ and η which we have defined. By making full use of this naturality, it is possible to avoid the necessity of having explicit formulas. First, however, we have to make two brief digressions in preparation for this proof.

Digression 1: Some more generalities on chain complexes

Definition 5.1. A chain complex $K = \{K_q\}$ is *positive* if $K_q = \{0\}$ for $q < 0$.

Most of the chain complexes we have considered so far have been positive. Note that the tensor product of two positive chain complexes is again a positive chain complex.

Definition 5.2. An *augmentation* of a positive chain complex $\{K_q, \partial_q\} = K$ is a homomorphism $\varepsilon : K_0 \rightarrow \mathbf{Z}$ such that $\varepsilon\partial_1 = 0$.

Observe that an augmentation ε induces a homomorphism $\varepsilon_* : H_0(K) \rightarrow \mathbf{Z}$.

Definition 5.3. A positive chain complex K with augmentation is *acyclic* if $H_q(K) = 0$ for $q \neq 0$ and $\varepsilon_* : H_0(K) \rightarrow \mathbf{Z}$ is an isomorphism.

For example, if X is a contractible space, then the chain complex $C(X)$ is acyclic.

Let K and L be positive chain complexes with augmentations. It should be clear what we mean when we say a chain map $f : K \rightarrow L$ “preserves the augmentation.” For example, if $\varphi : X \rightarrow Y$ is a continuous map, the induced chain map $\varphi_\# : C(X) \rightarrow C(Y)$ obviously preserves the augmentation. In the rest of this chapter, we will be mainly concerned with chain complexes which have an augmentation, and chain maps which preserve the augmentation.

Let $K' = \{K'_q, \partial'_q\}$ and $K'' = \{K''_q, \partial''_q\}$ be positive chain complexes with augmentation $\varepsilon' : K'_0 \rightarrow \mathbf{Z}$ and $\varepsilon'' : K''_0 \rightarrow \mathbf{Z}$, respectively. It is customary to define an augmentation ε on the tensor product $K = K' \otimes K''$ by the simple formula

$$\varepsilon(u \otimes v) = \varepsilon'(u) \cdot \varepsilon''(v)$$

for any $u \in K'_0$ and $v \in K''_0$. With this definition, the following diagram is obviously commutative:

$$\begin{array}{ccc}
 H_0(K') \otimes H_0(K'') & \xrightarrow{\alpha} & H_0(K' \otimes K'') \\
 \searrow e'_* \otimes e''_* & & \searrow \varepsilon_* \\
 \mathbf{Z} \otimes \mathbf{Z} & \xrightarrow{\approx} & \mathbf{Z}
 \end{array}$$

Proposition 5.4. *The tensor product of two free acyclic chain complexes (with augmentations) is again acyclic.*

This following from the Corollary 4.2 to the Künneth theorem and the commutative diagram above.

Digression 2. Let us denote by $\mu_n : Q_n(X) \rightarrow C_n(X)$ the natural homomorphism of $Q_n(X)$ onto its quotient group. It is obvious that $D_n(X)$ is a direct summand of $Q_n(X)$, hence we can choose (for each space X) a homomorphism $v_n : C_n(X) \rightarrow Q_n(X)$ such that $\mu_n v_n =$ identity map of $C_n(X)$. What is surprising is that we can do this in a *natural* way. To be precise:

Lemma 5.5. *There exist homomorphisms $v_n^X : C_n(X) \rightarrow Q_n(X)$, defined for each space X and each integer $n \geq 0$ such that $\mu_n v_n^X =$ identity, and for any continuous map $f : X \rightarrow Y$, the following diagram is commutative:*

$$\begin{array}{ccc}
 C_n(X) & \xrightarrow{v_n^X} & Q_n(X) \\
 \downarrow f_\# & & \downarrow f_\# \\
 C_n(Y) & \xrightarrow{v_n^Y} & Q_n(Y)
 \end{array}$$

PROOF. In order to save words, in the rest of this section we will call a homomorphism, such as v_n^X or μ_n^X , which is defined for each space X and commutes with the homomorphism $f_\#$ induced by any continuous map f , a *natural* homomorphism. As examples, we have the *face operators*

$$A_i, B_i : Q_n(X) \rightarrow Q_{n-1}(X), \quad 1 \leq i \leq n,$$

which were (almost) defined in §VII.2; they satisfy the identities listed in VII.2. Another important example is the family of *degeneracy operators*

$$E_i : Q_n(X) \rightarrow Q_{n+1}(X), \quad 1 \leq i \leq n + 1,$$

defined by

$$(E_i T)(x_1, \dots, x_{n+1}) = T(x_1, \dots, \hat{x}_i, \dots, x_{n+1})$$

for any singular n -cube $T : I^n \rightarrow X$; the circumflex over x_i means that it is to be omitted. Note that image $E_i \subset D_{n+1}(X)$, and every degenerate singular $(n + 1)$ -cube is of the form $E_i T$ for some i and some n -cube T . It is a routine matter to verify the following list of identities:

$$\begin{aligned}
E_i E_j &= E_{j+1} E_i, \quad i \leq j, \\
A_i E_j &= E_{j-1} A_i, \quad B_i E_j = E_{j-1} B_i, \quad i < j, \\
A_j E_j &= B_j E_j = 1, \\
A_i E_j &= E_j A_{i-1}, \quad B_i E_j = E_j B_{i-1}, \quad i > j.
\end{aligned}$$

Now consider the natural homomorphism

$$(1 - E_1 A_1)(1 - E_2 A_2) \cdots (1 - E_n A_n) : Q_n(X) \rightarrow Q_n(X).$$

We assert that this homomorphism annihilates $D_n(X)$, and hence defines a natural homomorphism

$$v_n : C_n(X) \rightarrow Q_n(X).$$

To prove this assertion, it helps to first prove the following identities:

$$\begin{aligned}
(1 - E_j A_j) E_j &= 0, \\
(1 - E_j A_j) E_i &= E_i (1 - E_{j-1} A_{j-1}) \quad \text{if } i < j.
\end{aligned}$$

It remains to verify that $\mu_n v_n = \text{identity}$. This follows from the fact that for any $u \in Q_n(X)$,

$$(1 - E_1 A_1)(1 - E_2 A_2) \cdots (1 - E_n A_n)(u)$$

belongs to the same coset modulo $D_n(X)$ as u .

Q.E.D.

With these digressions out of the way, we can proceed with our proof that $\zeta : C(X) \otimes C(Y) \rightarrow C(X \times Y)$ is a chain homotopy equivalence. The proof depends on the following three lemmas:

Lemma 5.6. *For every ordered pair of spaces (X, Y) we can choose a chain map*

$$\xi^{X,Y} : C(X \times Y) \rightarrow C(X) \otimes C(Y)$$

(which commutes with augmentations) such that the following naturality condition holds: For any continuous maps $f : X \rightarrow X'$ and $g : Y \rightarrow Y'$, the following diagram is commutative:

$$\begin{array}{ccc}
C(X \times Y) & \xrightarrow{\xi^{X,Y}} & C(X) \otimes C(Y) \\
\downarrow (f \times g)_\# & & \downarrow f_\# \otimes g_\# \\
C(X' \times Y') & \xrightarrow{\xi^{X',Y'}} & C(X') \otimes C(Y')
\end{array}$$

Lemma 5.7. *Let $\varphi^{X,Y}, \psi^{X,Y} : C(X) \otimes C(Y) \rightarrow C(X) \otimes C(Y)$ be a natural collection of chain maps. Then there exists a natural collection of chain homotopies*

$$D^{X,Y} : C(X) \otimes C(Y) \rightarrow C(X) \otimes C(Y)$$

such that

$$\varphi^{X,Y} - \psi^{X,Y} = \partial D^{X,Y} + D^{X,Y} \partial$$

for every ordered pair (X, Y) of spaces.

Lemma 5.8. *Let $\varphi^{X,Y}, \psi^{X,Y} : C(X \times Y) \rightarrow C(X \times Y)$ be a natural collection of chain maps. Then there exists a natural collection of chain homotopies $D^{X,Y} : C(X \times Y) \rightarrow C(X \times Y)$ such that*

$$\varphi^{X,Y} - \psi^{X,Y} = \partial D^{X,Y} + D^{X,Y} \partial.$$

In regard to the statements of these lemmas, the following points should be emphasized:

- (a) All chain maps are assumed to preserve the augmentation.
- (b) In each case, the adjective “natural” has the following technical meaning: Any pair of continuous maps $f : X \rightarrow X'$ and $g : Y \rightarrow Y'$ gives rise to a certain square diagram, which is required to be commutative.

It should be clear that these three lemmas imply the truth of the assertion that $\zeta : C(X) \otimes C(Y) \rightarrow C(X \times Y)$ is a chain homotopy equivalence. For, let $\xi : C(X \times Y) \rightarrow C(X) \otimes C(Y)$ be the chain map whose existence is guaranteed by Lemma 5.6. Then $\xi\zeta$ and the identity are natural chain maps $C(X) \otimes C(Y) \rightarrow C(X) \otimes C(Y)$, and hence they are chain homotopic by Lemma 5.7. Similarly, $\zeta\xi$ and the identity $C(X \times Y) \rightarrow C(X \times Y)$ are chain homotopic by Lemma 5.8. This result is known as the Eilenberg–Zilber theorem.

PROOF OF LEMMA 5.6. We will use induction on n to define homomorphisms

$$\xi_n^{X,Y} : C_n(X \times Y) \rightarrow [C(X) \otimes C(Y)]_n$$

for all spaces X and Y , which will be *natural*, and will define the required chain map (i.e., will commute with the boundary operator).

Case $n = 0$. Define

$$\xi_0^{X,Y} : C_0(X \times Y) \rightarrow C_0(X) \otimes C_0(Y)$$

by

$$\xi_0(S, T) = S \otimes T$$

for any singular 0-cubes $S : I^0 \rightarrow X$ and $T : I^0 \rightarrow Y$ [recall that $Q_0(W) = C_0(W)$ for any space W]. Then it is trivial to check that ξ_0 is natural and that it preserves the augmentation.

Case $n = 1$. Let $\iota : I^1 \rightarrow I^1$ denote the identity map. Then $(\iota, \iota) : I^1 \rightarrow (I^1 \times I^1)$ is a singular 1-cube, i.e., $(\iota, \iota) \in Q_1(I^1 \times I^1)$, and

$$\begin{aligned} \partial_1(\iota, \iota) &\in Q_0(I^1 \times I^1) = C_0(I^1 \times I^1), \\ \xi_0^{\iota, \iota} \partial_1(\iota, \iota) &\in C_0(I^1) \otimes C_0(I^1) \end{aligned}$$

and

$$\varepsilon \xi_0^{I^1, I^1} \partial_1(t, t) = \varepsilon \partial_1(t, t) = 0$$

since ξ_0 preserves augmentation. By Proposition 5.4, the chain complex $C(I^1) \otimes C(I^1)$ is acyclic. Hence we can choose an element

$$e^1 \in [C(I^1) \otimes C(I^1)]_1$$

such that

$$\partial_1(e^1) = \xi_0 \partial_1(t, t).$$

Define a homomorphism

$$\bar{\xi}_1^{X, Y} : Q_1(X \times Y) \rightarrow [C(X) \otimes C(Y)]_1$$

for any spaces X and Y by the formula

$$\bar{\xi}_1(S, T) = (S_{\#} \otimes T_{\#})(e_1),$$

where $S : I^1 \rightarrow X$ and $T : I^1 \rightarrow Y$ are arbitrary singular 1-cubes. We now have to check two things:

(a) **Naturality.** If $f : X \rightarrow X'$ and $g : Y \rightarrow Y'$ are continuous map, the following diagram is commutative:

$$\begin{array}{ccc} Q_1(X \times Y) & \xrightarrow{\bar{\xi}_1^{X, Y}} & [C(X) \otimes C(Y)]_1 \\ \downarrow (f \times g)_{\#} & & \downarrow f_{\#} \otimes g_{\#} \\ Q_1(X' \times Y') & \xrightarrow{\bar{\xi}_1^{X', Y'}} & [C(X') \otimes C(Y')]_1 \end{array}$$

This is an easy calculation:

$$\begin{aligned} (f_{\#} \otimes g_{\#}) \bar{\xi}_1(S, T) &= (f_{\#} \otimes g_{\#})(S_{\#} \otimes T_{\#})(e_1) \\ &= ((fS)_{\#} \otimes (gT)_{\#})(e_1), \\ \bar{\xi}_1(f \times g)_{\#}(S, T) &= \bar{\xi}_1(fS, gT) \\ &= ((fS)_{\#} \otimes (gT)_{\#})(e_1). \end{aligned}$$

(b) **Commutativity with ∂_1 ,** i.e., the following diagram is commutative:

$$\begin{array}{ccc} Q_1(X \times Y) & \xrightarrow{\bar{\xi}_1} & [C(X) \otimes C(Y)]_1 \\ \downarrow \partial_1 & & \downarrow \partial_1 \\ Q_0(X \times Y) & \xrightarrow{\xi_0} & [C(X) \otimes C(Y)]_0 \end{array}$$

Here the computation proceeds as follows:

$$\begin{aligned} \partial \bar{\xi}_1(S, T) &= \partial(S_{\#} \otimes T_{\#})(e_1) \\ &= (S_{\#} \otimes T_{\#}) \partial(e_1) \\ &= (S_{\#} \otimes T_{\#}) \xi_0 \partial(t, t) \end{aligned}$$

$$\begin{aligned} &= \xi_0(S \times T)_\# \partial(\iota, \iota) \\ &= \xi_0 \partial(S \times T)_\#(\iota, \iota) \\ &= \xi_0 \partial(S, T). \end{aligned}$$

Now define $\xi_1^{X,Y} : C_1(X \times Y) \rightarrow [C(X) \otimes C(Y)]_1$ by

$$\xi_1^{X,Y} = \bar{\xi}_1^{X,Y} v_1^{X,Y}.$$

Then ξ_1 is natural because it is the composition of natural homomorphisms. It remains to check that ξ_1 commutes with ∂_1 . Consider the following diagram:

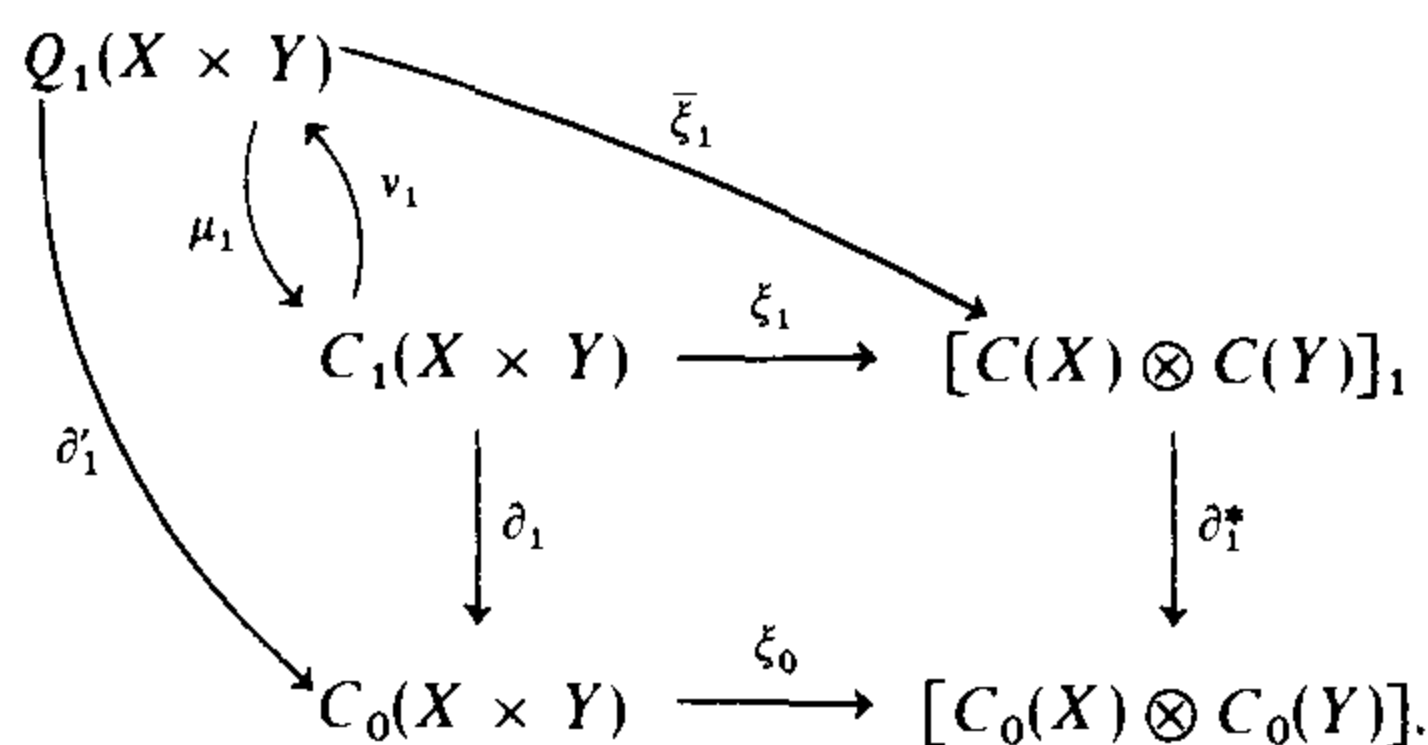

We wish to prove that

$$\partial_1^* \xi_1 = \xi_0 \partial_1.$$

We have

$$\begin{aligned} \partial_1^* \xi_1 &= \partial_1^* \bar{\xi}_1 v_1 = \xi_0 \partial_1' v_1, \\ \xi_0 \partial_1 &= \xi_0 \partial_1 \mu_1 v_1 = \xi_0 \partial_1' v_1, \end{aligned}$$

as desired.

Inductive step. Assume that $n > 1$ and homomorphisms

$$\xi_q^{X,Y} : C_q(X \times Y) \rightarrow [C(X) \otimes C(Y)]_q$$

have been defined for all spaces X and Y and all $q < n$ so that naturality holds and the homomorphisms commute with the boundary operator. Define homomorphisms

$$\bar{\xi}_q^{X,Y} : Q_q(X \times Y) \rightarrow [C(X) \otimes C(Y)]_q$$

for all X, Y and $q < n$ by the formula

$$\bar{\xi}_q^{X,Y} = \xi_q^{X,Y} \mu_q^{X,Y}.$$

Note that $\bar{\xi}_q$ is a natural homomorphism and that the various $\bar{\xi}_q$'s commute with the boundary operators ∂_q since they are the composition of homomorphisms having these two properties. Let $\iota : I^n \rightarrow I^n$ denote the identity map. Then $(\iota, \iota) : I^n \rightarrow I^n \times I^n$ is a singular n -cube, and $(\iota, \iota) \in Q_n(I^n \times I^n)$,

$$\begin{aligned} \bar{\xi}_{n-1}^{I^n, I^n} \partial_n(\iota, \iota) &\in [C(I^n) \otimes C(I^n)]_{n-1}, \\ \partial_{n-1} \bar{\xi}_{n-1} \partial_n(\iota, \iota) &= \bar{\xi}_{n-2} \partial_{n-1} \partial_n(\iota, \iota) = 0. \end{aligned}$$

Therefore, $\bar{\xi}_{n-1} \partial_n(\iota, \iota)$ is a cycle, and since $C(I^n) \otimes C(I^n)$ is acyclic, we can

choose $e_n \in [C(I^n) \otimes C(I^n)]_n$ such that

$$\partial(e_n) = \bar{\xi}_{n-1} \partial_n(l, l).$$

For any $S: I^n \rightarrow X$ and $T: I^n \rightarrow Y$, define

$$\bar{\xi}_n(S, T) = (S_{\#} \otimes T_{\#})(e_n).$$

Then $\bar{\xi}_n$ defines a homomorphism $Q_n(X \times Y) \rightarrow [C(X) \otimes C(Y)]_n$. Exactly as for the case $n = 1$, we can prove that $\bar{\xi}_n$ is *natural*. Also, the following diagram is commutative:

$$\begin{array}{ccc} Q_n(X \times Y) & \xrightarrow{\bar{\xi}_n} & [C(X) \otimes C(Y)]_n \\ \downarrow \partial_n & & \downarrow \partial_n \\ Q_{n-1}(X \times Y) & \xrightarrow{\bar{\xi}_{n-1}} & [C(X) \otimes C(Y)]_{n-1} \end{array}$$

In fact, we have

$$\begin{aligned} \partial_n \bar{\xi}_n(S, T) &= \partial_n (S_{\#} \otimes T_{\#})(e_n) \\ &= (S_{\#} \otimes T_{\#}) \partial_n(e_n) \\ &= (S_{\#} \otimes T_{\#}) \bar{\xi}_{n-1} \partial_n(l, l), \\ \bar{\xi}_{n-1} \partial_n(S, T) &= \bar{\xi}_{n-1} \partial_n(S \times T)_{\#}(l, l) \\ &= \bar{\xi}_{n-1} (S \times T)_{\#} \partial_n(l, l) \\ &= (S_{\#} \otimes T_{\#}) \bar{\xi}_{n-1} \partial_n(l, l). \end{aligned}$$

Next, define

$$\xi_n^{X,Y}: C_n(X \times Y) \rightarrow [C(X) \otimes C(Y)]_n$$

by

$$\xi_n^{X,Y} = \bar{\xi}_n^{X,Y} v_n^{X,Y}.$$

Then ξ_n is natural since it is the composition of natural homomorphisms. Also,

$$\partial_n \xi_n = \xi_{n-1} \partial_n;$$

for, we have

$$\begin{aligned} \partial_n \xi_n &= \partial_n \bar{\xi}_n v_n = \bar{\xi}_{n-1} \partial_n v_n \\ &= \xi_{n-1} \mu_{n-1} \partial_n v_n \\ &= \xi_{n-1} \partial_n \mu_n v_n = \xi_{n-1} \partial_n \end{aligned}$$

as desired. Q.E.D.

PROOF OF LEMMA 5.7. Once again we will use induction on n to define homomorphisms

$$D_n^{X,Y}: [C(X) \otimes C(Y)]_n \rightarrow [C(X) \otimes C(Y)]_{n+1}$$

for all integers n and all spaces X, Y , such that

$$\varphi_n^{X,Y} - \psi_n^{X,Y} = \partial_{n+1} D_n^{X,Y} + D_{n-1}^{X,Y} \partial_n$$

and such that naturality holds.

Case $n = 0$. We assert that the condition on φ and ψ imply that $\varphi_0^{X,Y} = \psi_0^{X,Y}$ for any spaces X and Y . The assertion is true for $X = Y = I^0$ (a single point) because $\varepsilon : C_0(I^0) \otimes C_0(I^0) \rightarrow \mathbf{Z}$ is an isomorphism, and φ and ψ are assumed to be augmentation preserving. For arbitrary spaces X and Y , let $S : I^0 \rightarrow X$ and $T : I^0 \rightarrow Y$ be singular 0-cubes. Then

$$S \otimes T = (S_{\#} \otimes T_{\#})(\iota \otimes \iota) \in C_0(X) \otimes C_0(Y),$$

where $\iota : I^0 \rightarrow I^0$ is the identity map. Hence, it follows by naturality that $\varphi_0^{X,Y} = \psi_0^{X,Y}$.

Since $\varphi_0^{X,Y} = \psi_0^{X,Y}$, we may define $D_0^{X,Y} = 0$ and all conditions will be satisfied.

For the remainder of the proof, it will be convenient to define homomorphisms

$$\bar{\varphi}_n^{X,Y}, \bar{\psi}_n^{X,Y} : [Q(X) \otimes Q(Y)]_n \rightarrow [C(X) \otimes C(Y)]_n$$

by the formulas

$$\bar{\varphi}_n^{X,Y} = \varphi_n^{X,Y}(\mu^X \otimes \mu^Y),$$

$$\bar{\psi}_n^{X,Y} = \psi_n^{X,Y}(\mu^X \otimes \mu^Y).$$

Then $\bar{\varphi}$ and $\bar{\psi}$ are natural chain mappings since they are the composition of natural chain mappings. Also, for any integer $q \geq 0$ we let

$$\iota_q : I^q \rightarrow I^q$$

denote the identity map.

Case $n = 1$. Consider

$$\iota_0 \otimes \iota_1 \in Q_0(I^0) \otimes Q_1(I^1)$$

and

$$\iota_1 \otimes \iota_0 \in Q_1(I^1) \otimes Q_0(I^0).$$

We now compute

$$\begin{aligned} \partial_1(\bar{\varphi}_1 - \bar{\psi}_1)(\iota_0 \otimes \iota_1) &= (\bar{\varphi}_0 - \bar{\psi}_0)\partial_1(\iota_0 \otimes \iota_1) \\ &= 0 \end{aligned}$$

since $\bar{\varphi}_0 = \varphi_0 = \psi_0 = \bar{\psi}_0$. Similarly, $\partial_1(\bar{\varphi}_1 - \bar{\psi}_1)(\iota_1 \otimes \iota_0) = 0$. Since the chain complexes $C(I^0) \otimes C(I^1)$ and $C(I^1) \otimes C(I^0)$ are acyclic, we can choose elements

$$e_{01} \in [C(I^0) \otimes C(I^1)]_2,$$

$$e_{10} \in [C(I^1) \otimes C(I^0)]_2$$

such that

$$\partial_2(e_{01}) = (\bar{\varphi}_1 - \bar{\psi}_1)(\iota_0 \otimes \iota_1),$$

$$\partial_2(e_{10}) = (\bar{\varphi}_1 - \bar{\psi}_1)(\iota_1 \otimes \iota_0).$$

Define $\bar{D}_1 : [Q(X) \otimes Q(Y)]_1 \rightarrow [C(X) \otimes C(Y)]_2$ by

$$\bar{D}_1(S \otimes T) = \begin{cases} (S_{\#} \otimes T_{\#})(e_{01}) & \text{if } S : I^0 \rightarrow X, T : I^1 \rightarrow Y \\ (S_{\#} \otimes T_{\#})(e_{10}) & \text{if } S : I^1 \rightarrow X, T : I^0 \rightarrow Y. \end{cases}$$

Then \bar{D}_1 is natural in the sense that the following diagram is commutative:

$$\begin{array}{ccc} [Q(X) \otimes Q(Y)]_1 & \xrightarrow{\bar{D}_1} & [C(X) \otimes C(Y)]_2 \\ \downarrow f_{\#} \otimes g_{\#} & & \downarrow f_{\#} \otimes g_{\#} \\ [Q(X') \otimes Q(Y')]_1 & \xrightarrow{\bar{D}_1} & [C(X') \otimes C(Y')]_2 \end{array}$$

The verification of naturality should present no difficulty to the reader who has already gone through details of such verifications earlier.

Next, if $S : I^0 \rightarrow X$ and $T : I^1 \rightarrow Y$ are singular cubes, we compute

$$\begin{aligned} \partial_2 \bar{D}_1(S \otimes T) &= \partial_2(S_{\#} \otimes T_{\#})(e_{01}) \\ &= (S_{\#} \otimes T_{\#})\partial_2(e_{01}) \\ &= (S_{\#} \otimes T_{\#})(\bar{\varphi}_1 - \bar{\psi}_1)(\iota_0 \otimes \iota_1) \\ &= (\bar{\varphi}_1 - \bar{\psi}_1)(S_{\#} \otimes T_{\#})(\iota_0 \otimes \iota_1) \\ &= (\bar{\varphi}_1 - \bar{\psi}_1)(S \otimes T). \end{aligned}$$

Similarly, we can prove that $\partial_2 \bar{D}_1(S \otimes T) = (\bar{\varphi}_1 - \bar{\psi}_1)(S \otimes T)$ in case $S : I^1 \rightarrow X$ and $T : I^0 \rightarrow Y$. Thus, we see that

$$\partial \bar{D}_1 = \bar{\varphi}_1 - \bar{\psi}_1,$$

in all cases.

Now define

$$D_1^{X,Y} : [C(X) \otimes C(Y)]_1 \rightarrow [C(X) \otimes C(Y)]_2$$

by

$$D_1^{X,Y} = \bar{D}_1^{X,Y}(v^X \otimes v^Y).$$

Then D_1 is natural because it is the composition of natural homomorphisms, and

$$\begin{aligned} \partial_2 D_1^{X,Y} &= \partial_2 \bar{D}_1^{X,Y}(v^X \otimes v^Y) \\ &= (\bar{\varphi}_1^{X,Y} - \bar{\psi}_1^{X,Y})(v^X \otimes v^Y) \\ &= (\varphi_1^{X,Y} - \psi_1^{X,Y})(\mu^X \otimes \mu^Y)(v^X \otimes v^Y) \\ &= (\varphi_1^{X,Y} - \psi_1^{X,Y})[(\mu^X v^X) \otimes (\mu^Y v^Y)] \\ &= \varphi_1^{X,Y} - \psi_1^{X,Y} \end{aligned}$$

as required.

Inductive step. Assume that $n > 1$ and

$$D_r : [C(X) \otimes C(Y)]_r \rightarrow [C(X) \otimes C(Y)]_{r+1}$$

is defined for all $r < n$, that D_r is natural, and

$$\varphi_r - \psi_r = \partial_{r+1} D_r + D_{r-1} \partial_r.$$

Define $\bar{D}_r : [Q(X) \otimes Q(Y)]_r \rightarrow [C(X) \otimes C(Y)]_{r+1}$ for all $r < n$ by

$$\bar{D}_r^{X,Y} = D_r^{X,Y}(\mu^X \otimes \mu^Y).$$

Then \bar{D}_r is natural, and

$$\begin{aligned} \partial_{r+1} \bar{D}_r &= \partial_{r+1} D_r(\mu^X \otimes \mu^Y) \\ &= (\varphi_r - \psi_r - D_{r-1} \partial_r)(\mu^X \otimes \mu^Y) \\ &= (\varphi_r - \psi_r)(\mu^X \otimes \mu^Y) - D_{r-1}(\mu^X \otimes \mu^Y) \partial_r \\ &= \bar{\varphi}_r - \bar{\psi}_r - \bar{D}_r \partial_r. \end{aligned}$$

Next, we define \bar{D}_n . Let (p, q) range over all pairs of non-negative integers such that $p + q = n$, and for each such pair consider $\iota_p \otimes \iota_q \in [Q(I^p) \otimes Q(I^q)]_n$ and

$$[\bar{\varphi}_n - \bar{\psi}_n - \bar{D}_{n-1} \partial_n](\iota_p \otimes \iota_q) \in [C(I^p) \otimes C(I^q)]_n.$$

We now compute as follows:

$$\begin{aligned} \partial_n [\bar{\varphi}_n - \bar{\psi}_n - \bar{D}_{n-1} \partial_n](\iota_p \otimes \iota_q) &= [\bar{\varphi}_{n-1} \partial_n - \bar{\psi}_{n-1} \partial_n - \partial_n \bar{D}_{n-1} \partial_n](\iota_p \otimes \iota_q) \\ &= [\partial_n \bar{D}_{n-1} \partial_n - \partial_n \bar{D}_{n-1} \partial_n](\iota_p \otimes \iota_q) = 0. \end{aligned}$$

Since $C(I^p) \otimes C(I^q)$ is acyclic, there exists $e_{p,q} \in [C(I^p) \otimes C(I^q)]_{n+1}$ such that

$$\partial(e_{p,q}) = [\bar{\varphi}_n - \bar{\psi}_n - \bar{D}_{n-1} \partial_n](\iota_p \otimes \iota_q).$$

If $S : I^p \rightarrow X$ and $T : I^q \rightarrow Y$ are singular cubes, define

$$\bar{D}_n(S \otimes T) = (S_{\#} \otimes T_{\#})(e_{p,q}).$$

Then $\bar{D}_n^{X,Y}$ is a homomorphism of $[Q(X) \otimes Q(Y)]_n$ into $[C(X) \otimes C(Y)]_{n+1}$. As before, we can easily prove that \bar{D}_n is a *natural* homomorphism, and

$$\begin{aligned} \partial_{n+1} \bar{D}_n(S \otimes T) &= \partial_{n+1} (S_{\#} \otimes T_{\#})(e_{p,q}) \\ &= (S_{\#} \otimes T_{\#}) \partial_{n+1} (e_{p,q}) \\ &= (S_{\#} \otimes T_{\#}) (\bar{\varphi}_n - \bar{\psi}_n - \bar{D}_{n-1} \partial_n)(\iota_p \otimes \iota_q) \\ &= (\bar{\varphi}_n - \bar{\psi}_n - \bar{D}_{n-1} \partial_n)(S_{\#} \otimes T_{\#})(\iota_p \otimes \iota_q) \\ &= (\bar{\varphi}_n - \bar{\psi}_n - \bar{D}_{n-1} \partial_n)(S \otimes T). \end{aligned}$$

We now define

$$D_n^{X,Y} : [C(X) \otimes C(Y)]_n \rightarrow [C(X) \otimes C(Y)]_{n+1}$$

by

$$D_n^{X,Y} = \bar{D}_n^{X,Y}(v^X \otimes v^Y).$$

Then D_n is natural, and

$$\begin{aligned} \partial_{n+1} D_n^{X,Y} &= \partial_{n+1} \bar{D}_n^{X,Y}(v^X \otimes v^Y) \\ &= (\bar{\varphi}_n - \bar{\psi}_1 - \bar{D}_{n-1} \partial_n)(v^X \otimes v^Y) \\ &= (\varphi_n - \psi_n - D_{n-1} \partial_n)(\mu^X \otimes \mu^Y)(v^X \otimes v^Y) \\ &= (\varphi_n^{X,Y} - \psi_n^{X,Y} - D_{n-1}^{X,Y} \partial_n) \end{aligned}$$

as required.

The reader should have no trouble by now proving Lemma 5.8 for himself, hence we will not go through the details.

The reader should reflect on the essentials of these proofs. They were concerned with certain chain complexes defined on ordered pairs (X, Y) of topological spaces, namely, $Q(X \times Y)$, $C(X \times Y)$, $Q(X) \otimes Q(Y)$, and $C(X) \otimes C(Y)$. There were certain *models* at hand: for $Q(X \times Y)$ they were the pairs (I^n, I^n) and the singular cube $(\iota, \iota) : I^n \rightarrow I^n \times I^n$, $(\iota, \iota) \in Q_n(I^n \times I^n)$, whereas for $Q(X) \otimes Q(Y)$ they were the pairs (I^p, I^q) and the elements $\iota_p \otimes \iota_q \in Q_p(I^p) \otimes Q_q(I^q)$. The important thing about the models is that $Q_n(X \times Y)$ has a basis composed of the elements $(S, T) = (S \times T)_\#(\iota, \iota)$, whereas $Q_p(X) \otimes Q_q(Y)$ has a basis composed of the elements $S \otimes T = (S_\# \otimes T_\#)(\iota_p \otimes \iota_q)$. Finally these models are *acyclic* in the sense that the chain complexes $C(I^n \times I^n)$ and $C(I^p) \otimes C(I^q)$ are acyclic. The whole procedure is explained in complete generality in the original paper of Eilenberg and Mac Lane [3]. However, such a general treatment is so abstract that it is difficult to follow; moreover, the reader who has used the method in a few specific cases should have no difficulty in applying it to new cases.

This method of acyclic models is applicable to many problems involving singular homology groups. For example, singular homology groups can be defined using singular simplexes rather than singular cubes. Then one can use the method of acyclic models to define a natural chain homotopy equivalence between cubical singular chains and simplicial singular chains. This is explained in detail in the paper of Eilenberg and Mac Lane [3] mentioned above.

EXERCISES

5.1. Prove that any two natural chain maps

$$\varphi^{X,Y}, \psi^{X,Y} : C(X) \otimes C(Y) \rightarrow C(X \times Y)$$

are chain homotopic (by a natural chain homotopy). [NOTE: This applies, in particular, to the natural chain map ζ defined in §3.]

5.2. Prove that there exist natural chain maps

$$\Delta^X : C(X) \rightarrow C(X) \otimes C(X)$$

and that any two such natural chain maps are chain homotopic (by a natural chain homotopy). Such a natural chain map is sometimes called a *diagonal map*.

5.3. Prove that there is a 1–1 correspondence between diagonal maps

$$\Delta^X : C(X) \rightarrow C(X) \otimes C(X)$$

as defined in the preceding exercise and natural chain maps

$$\xi^{X,Y} : C(X \times Y) \rightarrow C(X) \otimes C(Y)$$

as described in Lemma 5.6. This 1–1 correspondence is defined as follows:

(a) Given any such diagonal map Δ , define a natural chain map

$$\bar{\Delta}^{X,Y} : C(X \times Y) \rightarrow C(X) \otimes C(Y)$$

by the formula

$$\bar{\Delta}^{X,Y} = (\pi_{1\#} \otimes \pi_{2\#}) \Delta^{X \times Y},$$

where $\pi_1 : X \times Y \rightarrow X$ and $\pi_2 : X \times Y \rightarrow Y$ denote projections on the first and second factors, respectively.

(b) Given a natural chain map $\xi : C(X \times Y) \rightarrow C(X) \otimes C(Y)$, define a diagonal map

$$\xi^X : C(X) \rightarrow C(X) \otimes C(Y)$$

by the formula

$$\xi^X = \xi^{X,X} d_{\#},$$

where $d : X \rightarrow X \times X$ denotes the “diagonal” map defined by $d(x) = (x, x)$ for any $x \in X$. [NOTE: When we study cohomology theory, we will see the real importance of such diagonal maps.]

5.4. Let $\Delta^X : C(X) \rightarrow C(X) \otimes C(X)$ be a diagonal map, as defined in Exercise 5.2, and let $\tau^X : C(X) \otimes C(X) \rightarrow C(X) \otimes C(X)$ be the natural chain map defined by

$$\tau(u \otimes v) = (-1)^{pq} v \otimes u,$$

where $u \in C_p(X)$, and $v \in C_q(X)$. By Exercise 5.2, there exists a natural chain homotopy $D^X : C(X) \rightarrow C(X) \otimes C(X)$ between Δ and $\tau\Delta$, i.e.,

$$\Delta - \tau\Delta = \partial D + D\partial.$$

Prove by the method of acyclic models that there exist natural homomorphisms

$$D'_n : C_n(X) \rightarrow [C(X) \otimes C(X)]_{n+2}$$

such that

$$D + \tau D = \partial D' - D'\partial.$$

(Note that $\tau^2 = \text{identity}$. One can think of D' as a “second-order chain homotopy” between the “first-order” chain homotopies D and $-\tau D'$. One could then consider third-order chain homotopies between D' and $\tau D'$, etc. This procedure leads to one method of constructing the Steenrod squaring operations in cohomology theory; see E. Spanier [7, pp. 271–276].)

§6. Formulas for the Homology Groups of Product Spaces

Our objective is to combine the Künneth theorem for chain complexes (Theorem 4.1) with the existence of the natural chain homotopy equivalences (Eilenberg–Zilber theorem)

$$C(X) \otimes C(Y) \underset{\xi}{\overset{\zeta}{\rightleftarrows}} C(X \times Y)$$

to express the homology groups of $X \times Y$ in terms of those of X and Y .

By this method, we obviously obtain a split exact sequence:

$$0 \rightarrow \sum_{p+q=n} H_p(X) \otimes H_q(Y) \xrightarrow{\alpha} H_n(X \times Y) \xrightarrow{\beta} \sum_{p+q=n-1} \text{Tor}(H_p(X), H_q(Y)) \rightarrow 0.$$

The homomorphisms α and β are natural, but the splitting is not natural.

One way to generalize this theorem is the following: Let G be an abelian group. Then we have the following natural chain homotopy equivalences:

$$C(X) \otimes C(Y) \otimes G \underset{\xi \otimes 1}{\overset{\zeta \otimes 1}{\rightleftarrows}} C(X \times Y) \otimes G.$$

In the Künneth theorem we only needed to assume that one of the chain complexes K and L was free. Hence, we obtain the following split exact sequence:

$$\begin{aligned} 0 \rightarrow \sum_{p+q=n} H_p(X) \otimes H_q(Y; G) &\xrightarrow{\alpha} H_n(X \times Y; G) \\ &\xrightarrow{\beta} \sum_{p+q=n-1} \text{Tor}(H_p(X), H_q(Y; G)) \rightarrow 0. \end{aligned}$$

Once again, the homomorphisms α and β are natural, but the splitting is not natural.

We will now generalize these theorems to include relative homology groups. If (X, A) is a pair, then

$$C(X, A) = C(X)/C(A)$$

by definition; also, the sequence

$$0 \rightarrow C(A) \rightarrow C(X) \rightarrow C(X, A) \rightarrow 0$$

is split exact. Using these facts, plus basic properties of tensor products, it is easy to see that there is a natural isomorphism of chain complexes

$$\frac{C(X)}{C(A)} \otimes \frac{C(Y)}{C(B)} \approx \frac{C(X) \otimes C(Y)}{C(X) \otimes C(B) + C(A) \otimes C(Y)}$$

for any pairs (X, A) and (Y, B) . In the denominator on the right-hand side of this equation, the plus sign does *not* mean direct sum; it refers to the least subgroup containing the two terms.

Due to the naturality of the chain maps ζ and ξ with respect to the chain maps $i_{\#} : C(A) \rightarrow C(X)$ and $j_{\#} : C(B) \rightarrow C(Y)$ induced by inclusion maps i and j , we conclude that we have chain homotopy equivalences

$$\frac{C(X) \otimes C(Y)}{C(X) \otimes C(B) + C(A) \otimes C(Y)} \xrightleftharpoons[\xi]{\zeta} \frac{C(X \times Y)}{C(X \times B) + C(A \times Y)}$$

The inclusion maps $X \times B \rightarrow X \times B \cup A \times Y$ and $A \times Y \rightarrow X \times B \cup A \times Y$ induce an obvious chain map

$$C(X \times B) + C(A \times Y) \rightarrow C(X \times B \cup A \times Y).$$

Under certain circumstances, this chain map will be a chain homotopy equivalence; for example, this will be the case if either A or B is empty (trivially). More generally, it will be the case if the interiors of $X \times B$ and $A \times Y$ cover $X \times B \cup A \times Y$ (cf. Theorem VII.6.4) in the relative topology of $(X \times B) \cup (A \times Y)$.

Definition 6.1. Let X_1 and X_2 be subspaces of some topological space X . We say $\{X_1, X_2\}$ is an *excisive couple* if the obvious chain map $C(X_1) + C(X_2) \rightarrow C(X_1 \cup X_2)$ (induced by inclusion) induces isomorphisms on homology groups.

The term “excisive” is used here because of its obvious connection with the excision property.

We note the following two sufficient conditions for $\{X_1, X_2\}$ to be an excisive couple:

- (a) If $X_1 \cup X_2 = (\text{Interior } X_1) \cup (\text{Interior } X_2)$ in the relative topology of $X_1 \cup X_2$, then $\{X_1, X_2\}$ is an excisive couple. This is a consequence of Theorem VII.6.4.
- (b) If X is a CW-complex and X_1 and X_2 are subcomplexes, then $\{X_1, X_2\}$ is an excisive couple. This is a consequence of the theorems of §IX.4.

EXERCISES

6.1. Prove that the following conditions are equivalent to $\{X_1, X_2\}$ being an excisive couple in X :

- (a) $H_q(C(X_1 \cup X_2)/(C(X_1) + C(X_2))) = 0$ for all q .
- (b) The obvious chain map $C(X)/(C(X_1) + C(X_2)) \rightarrow C(X)/C(X_1 \cup X_2)$ induces isomorphisms on homology groups.
- (c) The inclusion map $(X_1, X_1 \cap X_2) \rightarrow (X_1 \cup X_2, X_2)$ induces isomorphisms on homology groups.

6.2. If $\{X_1, X_2\}$ is an excisive couple, prove that the chain map $C(X_1; G) + C(X_2; G) \rightarrow C(X_1 \cup X_2; G)$ induces an isomorphism on homology groups for any coefficient group G . Then deduce that the analogues of conditions (a), (b), and (c) of Exercise 6.1 hold for homology with coefficient group G .

In view of the above discussion, we see that if $\{A \times Y, X \times B\}$ is an excisive couple, then the composition of the Eilenberg–Zilber chain homotopy equivalence

$$C(X, A) \otimes C(Y, B) \xrightarrow{\zeta} \frac{C(X \times Y)}{C(X \times B) + C(A \times Y)}$$

and the chain map

$$\frac{C(X \times Y)}{C(X \times B) + C(A \times Y)} \rightarrow \frac{C(X \times Y)}{C(X \times B \cup A \times Y)}$$

induces an isomorphism

$$H_q(C(X, A) \otimes C(Y, B)) \approx H_q(X \times Y, X \times B \cup A \times Y)$$

for all q . Hence we have the following:

Theorem 6.2. *Let (X, A) and (Y, B) be pairs such that $\{A \times Y, X \times B\}$ is an excisive couple in $X \times Y$. Then there exists a split exact sequence*

$$\begin{aligned} 0 \rightarrow \sum_{p+q=n} H_p(X, A) \otimes H_q(Y, B; G) &\xrightarrow{\alpha} H_n(X \times Y, A \times Y \cup X \times B; G) \\ &\xrightarrow{\beta} \sum_{p+q=n-1} \text{Tor}(H_p(X, A), H_q(Y, B; G)) \\ &\rightarrow 0 \end{aligned}$$

The homomorphisms α and β are natural, but the splitting is not.

Examples

6.1. Let $K = \{K^n\}$ and $L = \{L^n\}$ be finite CW-complexes on the spaces X and Y respectively. Then

$$\alpha: H_p(K^p, K^{p-1}) \otimes H_q(L^q, L^{q-1}) \rightarrow H_{p+q}(K^p \times L^q, K^p \times L^{q-1} \cup K^{p-1} \times L^q)$$

is an isomorphism by the above theorem. Let

$$M^n = \bigcup_{p+q=n} K^p \times L^q, \quad n = 0, 1, 2, \dots,$$

denote the CW-complex on $X \times Y$. Then composing the isomorphism α with the homomorphism induced by the inclusion map

$$(K^p \times L^q, K^{p-1} \times L^q \cup K^p \times L^{q-1}) \rightarrow (M^n, M^{n-1})$$

gives rise to a natural homomorphism

$$C_p(K) \otimes C_q(L) \rightarrow C_n(M).$$

It may be shown that this agrees with the identification

$$C_n(M) = \sum_{p+q=n} C_p(K) \otimes C_q(L)$$

we made in §2 for the case where K and L are *regular* CW-complexes.

EXERCISES

- 6.3. Let K and L be pseudomanifolds of dimensions m and n , respectively. (a) Prove that $K \times L$ is a pseudomanifold of dimension $m + n$. (b) Prove that $K \times L$ is orientable if and only if both K and L are orientable.
- 6.4. Let P^2 denote the real projective plane. Compute the integral and mod 2 homology groups of $P^2 \times P^2$.
- 6.5. Let R be a ring, and let $K = \{K_n, \partial_n\}$ and $L = \{L_n, d_n\}$ be chain complexes such that each K_n is a right R -module, each ∂_n is a homomorphism of right R -modules, each L_n is a left R -module, and each d_n is a homomorphism of left R -modules (we can express these conditions more briefly by saying that K is a chain complex of right R -modules and L is a chain complex of left R -modules.) The definition of $K \otimes_R L$ should be obvious; it is a chain complex of abelian groups. Define a natural homomorphism $\alpha: H_p(K) \otimes_R H_q(L) \rightarrow H_{p+q}(K \otimes_R L)$ by analogy with our earlier definition.
- 6.6. Let F be a commutative field, and let K and L be chain complexes of vector spaces over F . Prove that

$$\alpha: \sum_{p+q=n} H_p(K) \otimes_F H_q(L) \rightarrow H_n(K \otimes_F L)$$

is an isomorphism.

- 6.7. Let (X, A) and (Y, B) be pairs such that $\{A \times Y, X \times B\}$ is an excisive couple in $X \times Y$, and let F be a commutative field. Prove that there exists a natural isomorphism

$$\alpha: \sum_{p+q=n} H_p(X, A; F) \otimes_F H_q(Y, B; F) \rightarrow H_n(X \times Y, A \times Y \cup X \times B; F).$$

- 6.8. Let F be a commutative field and (X, A) a pair such that for all q , the vector space $H_q(X, A; F)$ has finite rank r_q over F . Define the *Poincaré series* of (X, A) (over F) to be the formal power series

$$P(X, A; t) = \sum_{q \geq 0} r_q t^q.$$

Give a formula for $P(X \times Y; X \times B \cup A \times Y; t)$ in terms of $P(X, A; t)$ and $P(Y, B; t)$, assuming that $\{A \times Y, X \times B\}$ is an excisive couple.

References

1. H. Cartan and S. Eilenberg, *Homological Algebra*, Princeton University Press, Princeton, N.J., 1956, pp. 113.
2. A. Dold, *Lectures on Algebraic Topology*, Springer-Verlag, New York, 1972, p. 164.
3. S. Eilenberg and S. Mac Lane, *Acyclic models*, *Am. J. Math.* 75 (1953), 189–199.

4. P. Hilton and U. Stammbach, *A Course in Homological Algebra*, Springer-Verlag, New York, 1971, pp. 172ff.
5. A. T. Lundell and S. Weingram, *The Topology of CW-complexes*, Van Nostrand Reinhold Co., Princeton, N.J., 1969, pp. 56–59.
6. S. Mac Lane, *Homology*, Springer-Verlag, New York, 1963, Chapter V, §10.
7. E. Spanier, *Algebraic Topology*, McGraw-Hill, New York, 1966.
8. N. E. Steenrod, A convenient category of topological spaces, *Mich. Math. J.* **14** (1967), 133–152.
9. J. Vick, *Homology Theory*, Academic Press, New York, 1973, Chapter 4.

CHAPTER XII

Cohomology Theory

§1. Introduction

Recall that one obtains homology groups with coefficient group G by the following process:

- (a) Start with the chain complex $C(X, A) = \{C_q(X, A), \partial_q\}$.
- (b) Apply the functor $\otimes G$ to obtain the new chain complex

$$C(X, A) \otimes G = C(X, A; G).$$

- (c) Take the homology groups of the resulting chain complex:

$$H_q(X, A; G) = H_q(C(X, A; G)).$$

We could go through the same procedure, only at step (b), apply the functor $\text{Hom}(_, G)$ instead of $\otimes G$, and obtain what are called the *cohomology groups of (X, A) with coefficient group G* . Much of the resulting theory parallels that of Chapter X. However, the geometric interpretation of cycles (or cocycles), etc. is somewhat different, and perhaps a bit more obscure. More importantly, it is possible to introduce additional operations into cohomology theory, most notably, what are called *cup products* and *Steenrod squares*. These new operations are additional invariants of homotopy type, and enable us to distinguish between spaces that we could not tell apart otherwise. Cup products are explained in the next chapter.

§2. Definition of Cohomology Groups—Proofs of the Basic Properties

For any pair (X, A) and any abelian group G , define

$$C^q(X, A; G) = \text{Hom}(C_q(X, A), G),$$

and

$$\delta_q : C^q(X, A; G) \rightarrow C^{q+1}(X, A; G)$$

by $\delta_q = \text{Hom}(\partial_{q+1}, 1_G)$. Then

$$C^*(X, A; G) = \{C^q(X, A; G), \delta_q\}$$

is a *cochain complex*, in accordance with the following definition:

Definition 2.1. A *cochain complex* K consists of a sequence of abelian groups $\{K^q\}$ and homomorphisms $\delta_q : K^q \rightarrow K^{q+1}$ defined for all q and subject to the condition that $\delta_{q+1}\delta_q = 0$ for all q . The homomorphism δ_q is called a *coboundary operator*.

An important example of a cochain complex is the following: Let $C = \{C_q, \partial_q\}$ be a chain complex; define $K^q = \text{Hom}(C_q, G)$ and $\delta_q : K^q \rightarrow K^{q+1}$ by $\delta_q = \text{Hom}(\partial_{q+1}, 1)$, where 1 denotes the identity homomorphism $G \rightarrow G$. Then $K = \{K^q, \delta_q\}$ is a cochain complex; we will denote this cochain complex by

$$K = \text{Hom}(C, G).$$

On the other hand, if K is a cochain complex, then an analogous definition leads to a chain complex $\text{Hom}(K, G)$.

Obviously, the theory of chain complexes and the theory of cochain complexes are isomorphic; to get from one to the other, change the sign of all the indices. The distinction between the two is made partly for tradition, and partly for convenience in the applications we have in mind. Corresponding to the notions of *chain map* and *chain homotopy* we have *cochain maps* and *cochain homotopies*: Let K and L be cochain complexes. A *cochain map* $f : K \rightarrow L$ is a sequence of homomorphisms

$$f^q : K^q \rightarrow L^q$$

which commute with the coboundary operators. If $f, g : K \rightarrow L$ are cochain maps, then a cochain homotopy D between f and g is a sequence of homomorphisms $D^q : K^q \rightarrow L^{q-1}$ such that

$$f^q - g^q = \delta^{q-1}D^q + D^{q+1}\delta^q.$$

We leave it to the reader to define the following two concepts:

(a) Suppose C and C' are chain complexes and $f : C \rightarrow C'$ is a chain map.

Then a cochain map

$$\text{Hom}(f, 1) : \text{Hom}(C', G) \rightarrow \text{Hom}(C, G)$$

is defined.

(b) Assume C and C' are chain complexes, $f, g : C \rightarrow C'$ are chain maps, and $D : C \rightarrow C'$ is a chain homotopy between f and g . Then a cochain homotopy $\text{Hom}(D, 1)$ is defined between the cochain maps $\text{Hom}(f, 1)$ and $\text{Hom}(g, 1)$.

If $K = \{K^q\}$ is a cochain complex with coboundary operator $\delta^q : K^q \rightarrow K^{q+1}$, then the following notation and terminology is standard:

$$Z^q(K) = \text{kernel } \delta^q, \text{ the } q\text{-dimensional cocycles,}$$

$$B^q(K) = \text{image } \delta^{q-1}, \text{ the } q\text{-dimensional coboundaries,}$$

$$H^q(K) = Z^q(K)/B^q(K), \text{ the } q\text{-dimensional cohomology group.}$$

Thus, for any pair (X, A) and abelian group G , we have the cochain complex

$$C^*(X, A; G) = \text{Hom}(C(X, A), G)$$

and the associated cohomology groups

$$H^q(X, A; G) = H^q(C^*(X, A; G)).$$

Let $f : (X, A) \rightarrow (Y, B)$ be a continuous map of pairs; then we have the induced chain map,

$$f_{\#} : C(X, A) \rightarrow C(Y, B),$$

which gives rise to a cochain map

$$f^{\#} = \text{Hom}(f_{\#}, 1) : C^*(Y, B; G) \rightarrow C^*(X, A; G)$$

and hence to an induced homomorphism on cohomology groups

$$f^* : H^q(Y, B; G) \rightarrow H^q(X, A; G)$$

for all q . Note that the induced homomorphism in cohomology goes the opposite way from that in homology; we are dealing with a *contravariant* functor.

If two maps $f_0, f_1 : (X, A) \rightarrow (Y, B)$ are homotopic, then any homotopy $f : (X \times I, A \times I) \rightarrow (Y, B)$ gives rise to a chain homotopy $D : C(X, A) \rightarrow C(Y, B)$ between the chain maps $f_{0\#}$ and $f_{1\#}$. Hence, $\text{Hom}(D, 1)$ is a cochain homotopy between $f_0^{\#} = \text{Hom}(f_{0\#}, 1)$ and $f_1^{\#} = \text{Hom}(f_{1\#}, 1)$; it follows that the induced homomorphisms

$$f_0^*, f_1^* : H^q(Y, B; G) \rightarrow H^q(X, A; G)$$

are the same.

Next, we will discuss exact sequences. Let

$$E : 0 \rightarrow C' \xrightarrow{i} C \xrightarrow{j} C'' \rightarrow 0$$

be a short exact sequence of chain complexes and chain maps. If we apply the functor $\text{Hom}(_, G)$, we do not obtain a short exact sequence of cochain complexes, in general. All we can be certain of is that the following sequence is exact:

$$\text{Hom}(C', G) \xleftarrow{\text{Hom}(i, 1)} \text{Hom}(C, G) \xleftarrow{\text{Hom}(j, 1)} \text{Hom}(C'', G) \longleftarrow 0.$$

In general, $\text{Hom}(i, 1)$ will *not* be an epimorphism. However, if the sequence E is *split exact*, then the sequence

$$0 \leftarrow \text{Hom}(C', G) \leftarrow \text{Hom}(C, G) \leftarrow \text{Hom}(C'', G) \leftarrow 0$$

will also be split exact, and we will get a corresponding long exact sequence of cohomology groups.

We can apply these considerations to the short exact sequence of chain complexes

$$0 \rightarrow C(A) \xrightarrow{i_*} C(X) \xrightarrow{j_*} C(X, A) \rightarrow 0$$

for any pair (X, A) . This is a split exact sequence of chain complexes; hence, we obtain a corresponding split exact sequence of cochain complexes

$$0 \leftarrow C^*(A; G) \xleftarrow{i^*} C^*(X; G) \xleftarrow{j^*} C^*(X, A; G) \leftarrow 0$$

for any abelian group G . It follows that there is a long exact sequence of cohomology groups:

$$\cdots \xleftarrow{\delta^*} H^q(A; G) \xleftarrow{i^*} H^q(X; G) \xleftarrow{j^*} H^q(X, A; G) \xleftarrow{\delta^*} H^{q-1}(A; G)$$

will all the usual properties.

For all the usual properties.

For some purposes it is convenient to define *reduced* cohomology groups $\tilde{H}^0(X; G)$ in dimension 0. For this purpose, one uses the augmented chain complex $\tilde{C}(X)$ that is defined in §X.3. We define the *augmented cochain complex*

$$\tilde{C}^*(X; G) = \text{Hom}(\tilde{C}(X), G)$$

and the *reduced* cohomology groups

$$\tilde{H}^q(X; G) = H^q(\tilde{C}^*(X; G)).$$

One readily proves that for any nonempty space X and abelian group G ,

$$\tilde{H}^q(X; G) = H^q(X; G) \quad \text{for } q \neq 0,$$

whereas for $q = 0$ we have a split short exact sequence,

$$0 \rightarrow G \xrightarrow{\epsilon_*} H^0(X; G) \rightarrow \tilde{H}^0(X; G) \rightarrow 0.$$

We leave it for the reader to check that if P is a space consisting of a single point, then

$$\tilde{H}^q(P; G) = 0 \quad \text{for all } q.$$

From this it follows that

$$\varepsilon^* : G \rightarrow H^0(P; G)$$

is an isomorphism.

We will discuss the excision property and the Mayer–Vietoris sequence in cohomology later in this chapter.

§3. Coefficient Homomorphisms and the Bockstein Operator in Cohomology

Let $h : G_1 \rightarrow G_2$ be a homomorphism of abelian groups. Then for any chain complex C , we get an obvious cochain map

$$\text{Hom}(1, h) : \text{Hom}(C, G_1) \rightarrow \text{Hom}(C, G_2)$$

and an induced map on cohomology groups. In particular, for any pair (X, A) , we have the cochain map

$$\text{Hom}(1, h) : C^*(X, A; G_1) \rightarrow C^*(X, A; G_2)$$

and the induced homomorphism

$$h_{\#} : H^q(X, A; G_1) \rightarrow H^q(X, A; G_2)$$

on cohomology groups. The reader should state and prove naturality properties of the coefficient homomorphism $h_{\#}$ analogous to properties (a) and (b) of §X.5. In addition, he should prove that if G is a left module over some ring R , then $H^q(X, A; G)$ inherits a natural left R -module structure; in that case, the homomorphisms f^* and δ_* are homomorphisms of left R -modules.

Next, let

$$0 \rightarrow G' \xrightarrow{h} G \xrightarrow{k} G'' \rightarrow 0$$

be a short exact sequence of abelian groups. From this, we get the following sequence of cochain complexes:

$$0 \rightarrow C^*(X, A; G') \xrightarrow{\text{Hom}(1, h)} C^*(X, A; G) \xrightarrow{\text{Hom}(1, k)} C^*(X, A; G'') \rightarrow 0.$$

Since $C(X, A)$ is a chain complex of free abelian groups, it follows easily that this sequence of cochain complexes is exact. By the usual procedure, we get the following long exact sequence of cohomology groups:

$$\cdots \xrightarrow{\beta} H^q(X, A; G) \xrightarrow{h_{\#}} H^q(X, A; G) \xrightarrow{k_{\#}} H^q(X, A; G'') \xrightarrow{\beta} H^{q+1}(X, A; G').$$

Here β is the Bockstein operator in cohomology. It has naturality properties similar to that of the Bockstein operator in homomology.

§4. The Universal Coefficient Theorem for Cohomology Groups

The object of this theorem is to express $H^q(X, A; G)$ in terms of integral homology groups of (X, A) ; it is analogous to Corollary X.6.3.

Let $K = \{K_n, \partial_n\}$ be an arbitrary chain complex, G an abelian group, $x \in H_n(K)$, and $u \in H^n(\text{Hom}(K, G))$. The *inner product* $\langle u, x \rangle$ of u and x is the element of G obtained according to the following simple prescription: Choose a representative cocycle $u' \in \text{Hom}(K_n, G)$ for u , and a representative cycle $x' \in K_n$ for x . Then

$$\langle u, x \rangle = u'(x') \in G.$$

It is easy to verify that this definition is independent of the choice of the representatives u' and x' , and that the inner product is additive in each variable separately, i.e.,

$$\begin{aligned} \langle u_1 + u_2, x \rangle &= \langle u_1, x \rangle + \langle u_2, x \rangle, \\ \langle u, x_1 + x_2 \rangle &= \langle u, x_1 \rangle + \langle u, x_2 \rangle. \end{aligned}$$

This inner product is one of the basic ideas of cohomology theory.

Using this inner product, we define a homomorphism

$$\alpha : H^n(\text{Hom}(K, G)) \rightarrow \text{Hom}(H_n(K), G)$$

by the following rule: for any $u \in H^n(\text{Hom}(K, G))$ and $x \in H_n(K)$,

$$(\alpha u)(x) = \langle u, x \rangle.$$

The homomorphism α has the following three naturality properties (cf. §X.6):

(a) If $f : K \rightarrow K'$ is a chain map, then the following diagram is commutative:

$$\begin{array}{ccc} H^q(\text{Hom}(K, G)) & \xrightarrow{\alpha} & \text{Hom}(H_q(K), G) \\ \uparrow \text{Hom}(f, 1)^* & & \uparrow \text{Hom}(f_*, 1) \\ H^q(\text{Hom}(K', G)) & \xrightarrow{\alpha'} & \text{Hom}(H_q(K'), G) \end{array}$$

(b) Let $E : 0 \rightarrow K' \rightarrow K \rightarrow K'' \rightarrow 0$ be a split exact sequence of chain complexes. Then the following sequence of cochain complexes is also exact,

$$0 \leftarrow \text{Hom}(K', G) \leftarrow \text{Hom}(K, G) \leftarrow \text{Hom}(K'', G) \leftarrow 0,$$

and the following diagram is commutative:

$$\begin{array}{ccc} H^q(\text{Hom}(K', G)) & \xrightarrow{\alpha'} & \text{Hom}(H_q(K'), G) \\ \downarrow \delta^* & & \downarrow \text{Hom}(\partial_E, 1) \\ H^{q+1}(\text{Hom}(K'', G)) & \xrightarrow{\alpha''} & \text{Hom}(H_{q+1}(K''), G) \end{array}$$

(c) If $h : G_1 \rightarrow G_2$ is a homomorphism of coefficient groups, then the following diagram is commutative:

$$\begin{array}{ccc}
 H^q(\text{Hom}(K, G_1)) & \xrightarrow{\alpha} & \text{Hom}(H_q(K), G_1) \\
 \downarrow h_{\#} & & \downarrow \text{Hom}(1, h) \\
 H^q(\text{Hom}(K, G_2)) & \xrightarrow{\alpha} & \text{Hom}(H_q(K'), G_2)
 \end{array}$$

Of course, we will mainly be interested in the homomorphism in case $K = C(X, A)$:

$$\alpha : H^q(X, A; G) \rightarrow \text{Hom}(H_q(X, A); G).$$

We leave it to the reader to reformulate the naturality properties (a), (b), and (c) in an appropriate way for the cohomology of spaces.

In order to further investigate the properties of the homomorphism α , it is best to use homological algebra; in particular, it is necessary to make use of the functor $\text{Ext}(A, B)$. To be concise, $\text{Ext}(A, B)$ bears the same relation to $\text{Hom}(A, B)$ that $\text{Tor}(A, B)$ does to $A \otimes B$ (these are both examples of *first derived* functors). Although $\text{Tor}(A, B)$ is symmetric in the two variables, there can be no question of $\text{Ext}(A, B)$ being symmetrical since it is contravariant in the first variable and covariant in the second variable.

In order to make use of the functor Ext , it is convenient to have available certain basic properties of divisible abelian groups.

Definition 4.1. An abelian group A is *divisible* if given any $a \in A$ and any nonzero integer n , there exists an element $x \in A$ such that $nx = a$.

Examples

4.1. The additive group of rational numbers is divisible. It is easily proved that any quotient group of a divisible group is divisible, and any direct sum of divisible groups is divisible. Thus, we could construct many more examples.

In a certain sense, divisible groups have properties which are *dual* to those of free abelian groups. For example, any subgroup of a free abelian group is also free abelian, whereas any quotient group of a divisible group is divisible. Any free group F is *projective* (in the category of abelian groups), in the sense that given any epimorphism $h : A \rightarrow B$ and any homomorphism $g : F \rightarrow B$, there exists a homomorphism $f : F \rightarrow A$ such that the following diagram is commutative:

$$\begin{array}{ccccc}
 & & F & & \\
 & & \downarrow g & & \\
 & f & & & \\
 & \swarrow & & & \\
 A & \xrightarrow{h} & B & \longrightarrow & 0
 \end{array}$$

(the proof is easy).

Dually, an abelian group G is called *injective* if given any monomorphism $h: B \rightarrow A$ and any homomorphism $g: B \rightarrow G$, there exists a homomorphism $f: A \rightarrow G$ such that the following diagram is commutative:

$$\begin{array}{ccccc}
 & & G & & \\
 & & \uparrow g & & \\
 & A & \xrightarrow{f} & B & \xrightarrow{\quad} 0 \\
 & \leftarrow h & & & \\
 & & & &
 \end{array}$$

Note that this diagram is obtained from the previous one by reversing all the arrows.

Theorem 4.2. *An abelian group is injective if and only if it is divisible.*

The proof that an injective group is divisible is easy and is left to the reader.

Assume that G is divisible; we will prove that it is injective. Let A, B, h , and g be as in the diagram above. We may as well assume that B is a subgroup of A , and h is the inclusion map. Consider all pairs (G_i, h_i) where G_i is a subgroup of A which contains B , and $h_i: G_i \rightarrow G$ is a homomorphism such that $h_i|_B = g$. This family of pairs is nonvacuous because (B, g) obviously satisfies the required conditions. Define $(G_i, h_i) < (G_j, h_j)$ if $G_i \subset G_j$ and $h_j|_{G_i} = h_i$. Apply Zorn's lemma to this family with this ordering to conclude there exists a maximal pair (G_m, h_m) . We assert $G_m = A$; for if $G_m \neq A$, let $a \in A - G_m$; using the fact that G is divisible, it is easily shown that h_m can be extended to the subgroup generated by G_m and a . But this contradicts maximality of G_m .

It is well known that every abelian group is isomorphic to a quotient of a free abelian group. The following is the dual property:

Proposition 4.3. *Any group is isomorphic to a subgroup of a divisible group.*

PROOF. There are various ways to prove this. One way is to express the given group G as the quotient group of a free group F :

$$G \approx F/R.$$

Obviously F can be considered as a subgroup of a divisible group D ; for if $\{b_i\}$ is a basis for F , then we take D as a rational vector space on the same basis. Then G is isomorphic to a subgroup of the divisible group D/R .

Q.E.D.

We will now list the basic properties of $\text{Ext}(A, B)$. For any abelian groups A and B , $\text{Ext}(A, B)$ is also an abelian group. If $f: A' \rightarrow A$ and $g: B \rightarrow B'$ are homomorphisms, then

$$\text{Ext}(f, g): \text{Ext}(A, B) \rightarrow \text{Ext}(A', B')$$

is a homomorphism with the usual functorial properties.

There are two ways to define or construct $\text{Ext}(A, B)$:

(a) By means of a *free or projective resolution* of A . Choose a short exact sequence $0 \rightarrow F_1 \xrightarrow{d} F_0 \xrightarrow{\varepsilon} A \rightarrow 0$ with F_0 (and hence F_1) free abelian. Then the following sequence is exact:

$$0 \leftarrow \text{Ext}(A, B) \leftarrow \text{Hom}(F_1, B) \xleftarrow{\text{Hom}(d, 1)} \text{Hom}(F_0, B) \xleftarrow{\text{Hom}(\varepsilon, 1)} \text{Hom}(A, B) \leftarrow 0.$$

In other words, $\text{Ext}(A, B)$ is the cokernel of the homomorphism $\text{Hom}(d, 1)$.

(b) By means of an *injective resolution* of B . Choose a short exact sequence $0 \rightarrow B \xrightarrow{\varepsilon} D_0 \xrightarrow{d} D_1 \rightarrow 0$ with D_0 (and hence D_1) divisible. (By Proposition 4.3, such a sequence always exists.) Then the following sequence is exact:

$$0 \rightarrow \text{Hom}(A, B) \xrightarrow{\text{Hom}(1, \varepsilon)} \text{Hom}(A, D_0) \xrightarrow{\text{Hom}(1, d)} \text{Hom}(A, D_1) \rightarrow \text{Ext}(A, B) \rightarrow 0.$$

Thus, $\text{Ext}(A, B)$ is the cokernel of the homomorphism $\text{Hom}(1, d)$.

Naturally, one must prove that the group $\text{Ext}(A, B)$ is independent of the projective resolution in (a) and of the injective resolution in (b). Also, it must be proved that the two definitions give rise to the same group. For information on these matters, the reader is referred to books on homological algebra (see the bibliography for Chapter X).

The definition of the induced homomorphism $\text{Ext}(f, g)$ is left to the reader.

From these definitions, the following two statements are obvious consequences:

- (1) If A is a free abelian group, then $\text{Ext}(A, B) = 0$ for any group B .
- (2) If B is a divisible group, then $\text{Ext}(A, B) = 0$ for any group A .

Using the definition (a) above, one readily shows that:

$$(3) \text{Ext}(\mathbb{Z}_n, B) \approx B/nB, \quad \text{Hom}(\mathbb{Z}_n, B) \approx \{x \in B \mid nx = 0\}.$$

By means of (1) and (3), the structure of $\text{Ext}(A, B)$ can be determined in case A is a finitely generated abelian group.

We conclude this summary of the principal properties of the functor Ext by mentioning the following two exact sequences. Let

$$0 \rightarrow A \xrightarrow{h} B \xrightarrow{k} C \rightarrow 0$$

be a short exact sequence of abelian groups, and let G be an arbitrary abelian group. Then the following two sequences are exact:

$$\begin{aligned} 0 &\longrightarrow \text{Hom}(C, G) \xrightarrow{\text{Hom}(k, 1)} \text{Hom}(B, G) \xrightarrow{\text{Hom}(h, 1)} \text{Hom}(A, G) \\ &\longrightarrow \text{Ext}(C, G) \xrightarrow{\text{Ext}(k, 1)} \text{Ext}(B, G) \xrightarrow{\text{Hom}(h, 1)} \text{Ext}(A, G) \longrightarrow 0, \end{aligned} \tag{12.4.1}$$

$$\begin{aligned} 0 &\longrightarrow \text{Hom}(G, A) \xrightarrow{\text{Hom}(1, h)} \text{Hom}(G, B) \xrightarrow{\text{Hom}(1, k)} \text{Hom}(G, C) \\ &\longrightarrow \text{Ext}(G, A) \xrightarrow{\text{Ext}(1, h)} \text{Ext}(G, B) \xrightarrow{\text{Hom}(1, k)} \text{Ext}(G, C) \longrightarrow 0. \end{aligned} \tag{12.4.2}$$

In these exact sequences, the *connecting homomorphisms* $\text{Hom}(A, G) \rightarrow$

$\text{Ext}(C, G)$ and $\text{Hom}(G, C) \rightarrow \text{Ext}(G, A)$ have all the naturality properties that one might expect.

With these preliminaries out of the way, we can now state the main result in this area:

Theorem 4.4. (*Universal coefficient theorem for cohomology*). *Let K be a chain complex of free abelian groups, and let G be an arbitrary abelian group. Then there exists a split exact sequence*

$$0 \rightarrow \text{Ext}(H_{n-1}(K), G) \xrightarrow{\beta} H^n(\text{Hom}(K, G)) \xrightarrow{\alpha} \text{Hom}(H_n(K), G) \rightarrow 0.$$

The homomorphism β is natural, with respect to coefficient homomorphisms and chain maps. The splitting is natural with respect to coefficient homomorphisms but not with respect to chain maps.

PROOF. The proof we present is dual to that given in §X.6. For the reader who has some feeling for this duality, it is a purely mechanical exercise to transpose the previous proof to the present one.

First, we need a lemma, which is the dual of Lemma X.6.1.

Lemma 4.5. *If G is a divisible group, then the homomorphism*

$$\alpha : H^n(\text{Hom}(K, G)) \rightarrow \text{Hom}(H_n(K), G)$$

is an isomorphism for any chain complex K .

The proof of this lemma is a nice exercise, involving the various definitions and the fact that divisible groups are injective.

Now we will prove the theorem. Let

$$0 \rightarrow G \xrightarrow{\varepsilon} D_0 \xrightarrow{d} D_1 \rightarrow 0$$

be a short exact sequence with D_0 and D_1 divisible [see Property (b)]. Consider the corresponding long exact sequence in cohomology, and the following commutative diagram:

$$\begin{array}{ccccccc} \cdots & \xrightarrow{\beta_0} & H^n(\text{Hom}(K, G)) & \xrightarrow{\varepsilon_{\#}} & H^n(\text{Hom}(K, D_0)) & \xrightarrow{d_{\#}} & H^n(\text{Hom}(K, D_1)) & \xrightarrow{\beta_0} & \cdots \\ & & \downarrow \alpha & & \downarrow \alpha_0 & & \downarrow \alpha_1 & & \\ 0 & \longrightarrow & \text{Hom}(H_n(K), G) & \xrightarrow{\text{Hom}(1, \varepsilon)} & \text{Hom}(H_n(K), D_0) & \xrightarrow{\text{Hom}(1, d)} & \text{Hom}(H_n(K), D_1) & \longrightarrow & 0 \end{array}$$

The bottom line is exact by the standard properties of the functor Hom , and the diagram is commutative by the naturality properties of α . Also, α_0 and α_1 are isomorphisms since D_0 and D_1 are divisible groups. From this diagram one deduces that α is an epimorphism, and $\text{kernel } \alpha = \text{kernel } \varepsilon_{\#}$.

Next, one considers the following similar diagram:

$$\begin{array}{ccccccc}
 \cdots & \xrightarrow{\varepsilon_{\#}} & H^{n-1}(\text{Hom}(K, D_0)) & \xrightarrow{d_{\#}} & H^{n-1}(\text{Hom}(K, D_1)) & \xrightarrow{\beta_0} & H^n(\text{Hom}(K, G)) \xrightarrow{\varepsilon_{\#}} \cdots \\
 & & \downarrow \alpha_0 & & \downarrow \alpha_1 & & \boxed{1} \\
 \cdots & \longrightarrow & \text{Hom}(H_{n-1}(K), D_0) & \xrightarrow{\text{Hom}(1, d)} & \text{Hom}(H_{n-1}(K), D_1) & \longrightarrow & \text{Ext}(H_{n-1}(K), G) \longrightarrow 0.
 \end{array}$$

Once again the bottom line is exact, and the diagram is commutative; as before, α_0 and α_1 are isomorphisms. One now proves that there is a unique homomorphism

$$\beta: \text{Ext}(H_{n-1}(K), G) \rightarrow H^n(\text{Hom}(K, G))$$

which makes the square labeled 1 commutative. Then one proves that β is a monomorphism, and $\text{image } \beta = \text{image } \beta_0$. Since $\text{image } \beta_0 = \text{kernel } \varepsilon_{\#}$, it follows that $\text{image } \beta = \text{kernel } \alpha$.

It remains to prove that the short exact sequence of the theorem splits. This can be done by the method used in the proof of Theorem X.6.2, modified to cover the case at hand. The details are left to the reader.

Corollary 4.6. *For any pair (X, A) and any abelian group G there exists a split short exact sequence:*

$$0 \rightarrow \text{Ext}(H_{n-1}(X, A), G) \xrightarrow{\beta} H^n(X, A; G) \xrightarrow{\alpha} \text{Hom}(H_n(X, A), G) \rightarrow 0.$$

The homomorphisms α and β are natural with respect to homomorphisms induced by continuous maps of pairs and coefficient homomorphisms. The splitting can be chosen to be natural with respect to coefficient homomorphisms, but not with respect to homomorphisms induced by continuous maps.

EXERCISES

- 4.1. Let (X, A) be a pair such that $H_n(X, A)$ is a finitely generated abelian group for all n . Prove that $H^n(X, A; \mathbf{Z})$ is also finitely generated for all n , and that

$$\text{rank}(H^n(X, A; \mathbf{Z})) = \text{rank}(H_n(X, A)),$$

$$\text{Torsion}(H^n(X, A; \mathbf{Z})) \approx \text{Torsion}(H_{n-1}(X, A)).$$

- 4.2. Prove that $\alpha: H^n(X, A; G) \rightarrow \text{Hom}(H_n(X, A), G)$ is an isomorphism for $n = 0, 1$ (for any pair (X, A) and any group G).

- 4.3. For any pair (X, A) , prove that $H^1(X, A; \mathbf{Z})$ is a torsion-free abelian group.

- 4.4. Let X be a finite regular graph. Express the structure of the cohomology groups $H^n(X, G)$ in terms of the Euler characteristic and number of components of \mathbf{X} .

- 4.5. Describe the structure of the cohomology groups $H^q(S^n; G)$ and $H^q(E^n, S^{n-1}; G)$ for all q, n , and G .

- 4.6. Let X be an n -dimensional pseudomanifold as defined in §IX.8. Determine the structure of $H^n(X; G)$.

- 4.7. Let X be a compact connected 2-dimensional manifold. Determine the structure of $H^n(X; G)$ for all n and G (use the classification theorem for such manifolds to express your final result).
- 4.8. Let $K = \{K^n\}$ be a finite dimensional CW-complex on the space X . Prove that there is an isomorphism $H^n(X; G) \approx H^n(\text{Hom}(C(K), G))$ for all n and G (here $C(K) = \{H_q(K^q, K^{q-1})\}$ is a chain complex described in §X.7. Prove also that this isomorphism has the following naturality property: Let L be a CW-complex on Y and $f: X \rightarrow Y$ a continuous map which is *cellular*, i.e., $f(K^n) \subset L^n$ for all n . Then there is an induced chain map $f_*: C(K) \rightarrow C(L)$, and the following diagram is commutative:

$$\begin{array}{ccc} H^n(X; G) \approx H^n(\text{Hom}(C(K), G)) & & \\ \uparrow f^* & & \uparrow \text{Hom}(f_*, 1)^* \\ H^n(Y; G) \approx H^n(\text{Hom}(C(L), G)) & & \end{array}$$

- 4.9. Consider continuous maps $f: P^2 \rightarrow S^2$, where P^2 denotes the real projective plane. By considering the induced homomorphism $f^*: H^2(S^2; \mathbf{Z}) \rightarrow H^2(P^2; \mathbf{Z})$, show that there are at least two homotopy classes of such maps (cf. the example in §X.7. Use the results of Exercise 4.8).
- 4.10. Show that the homomorphism $f^*: H^n(Y, B; G) \rightarrow H^n(X, A; G)$ induced by a continuous map $f: (X, A) \rightarrow (Y, B)$ is *not* determined by knowledge of the homomorphisms on homology

$$f_*: H_q(X, A) \rightarrow H_q(Y, B)$$

for all q .

- 4.11. Prove that the splitting of the short exact sequence of Corollary 4.6 *cannot* be chosen to be natural with respect to homomorphisms induced by continuous maps.

§5. Geometric Interpretation of Cochains, Cocycles, etc.

In homology theory it is not difficult to have some geometric intuition about chains, cycles, bounding cycles, etc. This geometric intuition is often of assistance in leading one to the correct solution of problems. Unfortunately, these things are more complicated for cohomology theory.

In order to understand the situation better, let us first reconsider homology theory. Let $K = \{K^n\}$ be a CW-complex on the space X , and let $u \in C_n(K, G)$; then u has a unique expression of the form

$$u = \sum_i g_i e_i^n,$$

where $g_i \in G$ and the e_i^n are oriented n -cells of K . It is natural to associate with

the chain u the subset

$$|u| = \bigcup_i \bar{e}_i^n,$$

where the union is over all cells e_i^n such that the corresponding coefficient $g_i \neq 0$. If $u = 0$, we define $|u| = \emptyset$. The set $|u|$ is called the *support of u* . It has the following properties:

- (a) $|u|$ is a compact subset of X .
- (b) $|u| = \emptyset$ if and only if $u = 0$.
- (c) $|u \pm v| \subset |u| \cup |v|$.
- (d) $|d_n u| \subset |u|$.

Of course, the chain u is not determined by the set $|u| \subset X$ (except in the case where $G = \mathbb{Z}_2$), but the structure of the set $|u|$ is a vital piece of information about u . One thinks of u as determined by $|u|$ and the coefficients g_i which are assigned to various oriented subsets of $|u|$.

There is also a natural way to define the support of a singular chain u in an arbitrary topological space X . Let $u \in C_n(X, G)$; if $u = 0$, we define $|u| = \emptyset$. If $u \neq 0$, then u has a unique expression as a finite linear combination of nondegenerate singular n -cubes with nonzero coefficients,

$$u = \sum_i g_i T_i, \quad g_i \in G,$$

and it is natural to define

$$|u| = \bigcup_i T_i(I^n).$$

It is clear that properties (a)–(d) continue to hold. However, it is also clear that in this situation $|u|$ does not give us much information about u as it did in the previous situation. The reason is that two quite different nondegenerate n -cubes may have the same image set, i.e., we may have n -cubes

$$T_1, T_2 : I^n \rightarrow X$$

such that $T_1(I^n) = T_2(I^n)$, yet $T_1 \neq T_2$.

We will now try to define the support of a cochain so that properties (a)–(d) will hold. First, it is convenient to formulate the definition of a cochain in a slightly different, but equivalent, way. This alternate definition is based on the following principle: *Let F be a free abelian group with basis $B \subset F$, and let G be an arbitrary abelian group. Then there is a natural 1–1 correspondence between homomorphisms $u : F \rightarrow G$ and arbitrary functions $f : B \rightarrow G$. This correspondence is established by assigning to each such homomorphism u the function $f = u|_B$, the restriction of u to B , and to each such function f its unique linear extension u .*

Let us apply this principle to the n -cochains of a CW-complex K on the space X . Let $u \in C^n(K, G) = \text{Hom}(C_n(K), G)$. The chain group $C_n(K)$ has as natural basis the set of n -cells $\{e_i^n\}$, where a definite orientation has been chosen for each such cell. Thus, we can think of u as a function which assigns

to each such oriented n -cell e_i^n an element $u(e_i^n) \in G$. In view of the previous definition for support of a chain, it seems natural to define $|u|$ to be the union of all closed n -cells \bar{e}_i^n , such that $u(\bar{e}_i^n) \neq 0$. However, experience has shown that this definition definitely does not work! The main trouble is that the analogue of condition (d) above does not hold.

We will indicate a way to correct this deficiency for the case of cochains in a *regular* CW-complex. Recall that given a regular CW-complex, for each cell e_i^n there exists a characteristic map

$$f_i: (E^n, S^{n-1}) \rightarrow (\bar{e}_i^n, \dot{e}_i^n)$$

which is a homeomorphism. Of course, if $n > 0$, there will exist for each cell e_i^n infinitely many such maps which are homeomorphisms, and there is no reason to prefer one over another. We will assume that for each e_i^n one such characteristic map has been chosen and call it the *preferred* characteristic map. By means of this preferred characteristic map, geometric concepts which are valid for E^n can be carried over to \bar{e}_i^n . In particular, we wish to carry over the following two concepts from E^n to \bar{e}_i^n :

(1) The center of the cell E^n is the origin, $(0, 0, \dots, 0)$. By definition, the *center* of e_i^n is the image of the center of E^n under the preferred characteristic map.

(2) If A is any subset of S^{n-1} , the *cone over* A , denoted by $\Gamma(A)$, is the following subset of E^n :

$$\Gamma(A) = \{t \cdot a \mid a \in A \text{ and } 0 \leq t \leq 1\},$$

i.e., $\Gamma(A)$ is the union of all straight line segments joining the origin to points $a \in A$. Analogously, if A is any subset of \dot{e}_i^n , then $\Gamma(A)$ is a subset of \bar{e}_i^n , defined using the preferred characteristic map for the cell e_i^n . Note that if A is a closed set, then so is $\Gamma(A)$. More generally, if A is a subset of the $(n-1)$ -skeleton K^{n-1} , then we define $\Gamma(A)$ to be the union of A and the sets $\Gamma(A \cap \dot{e}_i^n)$ for all n -cells e_i^n . $\Gamma(A)$ is a subset of K^n , and if A is closed, so is $\Gamma(A)$ because of the weak topology. We can iterate this procedure, defining

$$\Gamma^2(A) = \Gamma(\Gamma(A)),$$

$$\Gamma^n(A) = \Gamma(\Gamma^{n-1}(A)),$$

$$\Gamma^\infty(A) = \bigcup_{n=1}^{\infty} \Gamma^n(A).$$

We will mainly be interested in this operation for the case of a finite-dimensional CW-complex. Then $\Gamma^\infty(A)$ is attained after a finite number of iterations.

Now let $u \in C^n(K, G)$; consider u as a function defined on oriented n -cells e_i^n with values in G . Define A to be the set of all center points of all cells e_i^n such that $u(e_i^n) \neq 0$. Then A is a closed, discrete subset of X ; however, it is not compact, in general. We define

$$|u| = \Gamma^\infty(A).$$

If K is finite dimensional, it is clear that $|u|$ is a closed subset of X . One can also verify the analogue of conditions (b), (c), and (d):

$$\begin{aligned} |u| &= \emptyset \quad \text{if and only if } u = 0, \\ |u \pm v| &\subset |u| \cup |v|, \\ |\delta(u)| &\subset |u|. \end{aligned}$$

Although rather complicated, this seems to be the proper definition. The fact that $|u|$ is noncompact in general is not a defect in our definition, it is an inherent property of the cohomology theory we are using. It is possible to define a cohomology theory based on cochains with “compact supports,” but we will not do this for the present.

Note that if K is a CW-complex of dimension N , and $u \in C^k(K, G)$, then $|u|$ is a set of dimension $\leq N - k$. Thus, as k increases, the dimension of $|u|$ decreases. This is just the opposite of what happens with chains.

There is also a definition of support of singular cochains in a general space which we will now consider, although it is less satisfactory than that we have just given.

If $u \in C^n(X, G) = \text{Hom}(C_n(X), G)$, then u is a homomorphism of $C_n(X) = Q_n(X)/D_n(X)$ into G . Hence, we can regard u as a function which is defined on singular n -cubes with values in G and vanishes on all degenerate singular n -cubes. Rather than defining $|u|$, it will be more convenient to define the complementary set: A point x does *not* belong to $|u|$ if and only if there is an open neighborhood U of x such that $u(T) = 0$ for all singular n -cubes $T: I^n \rightarrow U$. From this definition it is clear that the complementary set is open; hence, $|u|$ is closed. We also have the following properties:

$$\begin{aligned} u = 0 \quad &\text{implies } |u| = \emptyset, \\ |u \pm v| &\subset |u| \cup |v|, \\ |\delta u| &\subset |u|. \end{aligned}$$

Unfortunately, we can have nonzero cochains u such that $|u| = \emptyset$. This defect can be remedied by factoring out all such cochains (i.e., passing to a quotient group). By using Theorem VII.6.4 it can be proved that this process does not change the resulting cohomology theory. However, we will have no need to pursue this matter further, (cf. Massey, [1, Lemma 8.16, p. 260]).

§6. Proof of the Excision Property; the Mayer–Vietoris Sequence

Let (X, A) be a pair and let W be a subset of A . We then have the following split exact sequence of chain complexes (cf. §X.6):

$$0 \rightarrow C(X - W, A - W) \xrightarrow{i_*} C(X, A) \rightarrow \frac{C(X, A)}{C(X - W, A - W)} \rightarrow 0.$$

Note that these are all chain complexes of free abelian groups. By passing to the long exact homology sequence, we see that $i_* : H_q(X - W, A - W) \rightarrow H_q(X, A)$ is an isomorphism for all q if and only if $H_q(C(X, A)/C(X - W, A - W)) = 0$ for all q .

We may also apply the functor $\text{Hom}(_, G)$ to the above split exact sequence of chain complexes, obtaining the following exact sequence:

$$0 \leftarrow C^*(X - W, A - W; G) \xleftarrow{i_*} C^*(X, A; G) \\ \leftarrow \text{Hom}\left(\frac{C(X, A)}{C(X - W, A - W)}, G\right) \leftarrow 0.$$

Passing to cohomology, we see that $i^* : H^q(X, A; G) \rightarrow H^q(X - W, A - W; G)$ is an isomorphism for all q if and only if $H^q(\text{Hom}(C(X, A)/C(X - W, A - W), G)) = 0$ for all q . Making use of Theorem 4.4, one concludes that the excision property for integral homology implies a corresponding property for cohomology: *If W is a subset of A such that $\overline{W} \subset \text{interior } A$, then $i^* : H^q(X, A; G) \rightarrow H^q(X - W, A - W; G)$ is an isomorphism for all q .*

Let \mathcal{U} be an open covering of X , or more generally, a family of sets whose interiors cover X . It is known that the inclusion

$$\sigma : C(X, A, \mathcal{U}) \rightarrow C(X, A)$$

induces an isomorphism on homology (Theorem VII.6.4). By the same type of argument as that just given, it can be shown that the induced homomorphism on cochain complexes

$$\text{Hom}(\sigma, 1) : C^*(X, A; G) \rightarrow C^*(X, A, \mathcal{U}; G)$$

also induces an isomorphism on passage to cohomology. This fact can be used to prove the existence of the Mayer–Vietoris sequence for cohomology as follows. Let A and B be subsets of X such that

$$X = (\text{interior } A) \cup (\text{interior } B).$$

Then we may take $\mathcal{U} = \{A, B\}$, and $\sigma : C(X, \mathcal{U}) \rightarrow C(X)$ will have the properties described above. In §VII.5 we introduced the commutative diagram of chain complexes

$$\begin{array}{ccccc} & & C(A) & & \\ & i_* \nearrow & & \searrow k_* & \\ C(A \cap B) & & & & C(X, \mathcal{U}) \\ & j_* \searrow & & \nearrow l_* & \\ & & C(B) & & \end{array}$$

and the following short exact sequence

$$0 \rightarrow C(A \cap B) \xrightarrow{\Phi} C(A) \oplus C(B) \rightarrow C(X, \mathcal{U}) \rightarrow 0$$

in order to prove the Mayer–Vietoris sequence for homology theory. Recall that Φ and Ψ are defined by

$$\Phi(x) = (i_{\#}x, j_{\#}x), \quad \Psi(u, v) = k_{\#}(u) - l_{\#}(v).$$

Also, $C(X, \mathcal{U})$ is a chain complex of free abelian groups, hence the short exact sequence splits. Therefore, we may apply the functor $\text{Hom}(\ , G)$ to obtain the following short exact sequence of cochain complexes:

$$0 \leftarrow C^*(A \cap B; G) \leftarrow C^*(A; G) \oplus C^*(B; G) \leftarrow C^*(X, \mathcal{U}; G) \leftarrow 0.$$

It is readily verified that homomorphisms $\text{Hom}(\Phi, 1)$ and $\text{Hom}(\Psi, 1)$ have the following expression in terms of $i^{\#}, j^{\#}, k^{\#}$, and $l^{\#}$:

$$\text{Hom}(\Psi, 1)(x) = (k^{\#}(x), -l^{\#}(x)),$$

$$\text{Hom}(\Phi, 1)(u, v) = i^{\#}u + j^{\#}v.$$

Therefore, we may pass to the corresponding long exact sequence of cohomology groups and make use of the isomorphism $H^q(X, \mathcal{U}; G) \approx H^q(X; G)$ to obtain the *Mayer–Vietoris sequence in cohomology*:

$$\cdots \xleftarrow{\psi} H^{q+1}(X; G) \xleftarrow{\Delta} H^q(A \cap B; G) \xleftarrow{\varphi} H^q(A; G) \oplus H^q(B; G) \xleftarrow{\psi} H^q(X; G) \xleftarrow{\Delta} \cdots.$$

Here

$$\psi(x) = (k^*(x), -l^*(x)),$$

$$\varphi(u, v) = i^*(u) + j^*(v).$$

It should be remarked that there are other ways of deriving the Mayer–Vietoris sequence for cohomology.

EXERCISES

6.1. Let $K = \{K_q, \partial_q\}$ be a chain complex such that each K_q is a vector over a commutative field F , and each ∂_q is linear over F . Define the cochain complex $\text{Hom}_F(K, V)$, where V is a vector space over F , and the natural homomorphism

$$\alpha : H^q(\text{Hom}_F(K, V)) \rightarrow \text{Hom}_F(H^q(K), V).$$

Prove that α is an isomorphism.

6.2. Let $\{X_1, X_2\}$ be an excisive couple in the space X , as defined in §IX.6. Prove that the inclusion map $i : \{X_1, X_1 \cap X_2\} \rightarrow \{X_1 \cup X_2, X_2\}$ induces an isomorphism

$$i^* : H^q(X_1 \cup X_2, X_2; G) \rightarrow H^q(X_1, X_1 \cap X_2; G)$$

for all q and all groups G .

We will conclude this chapter by pointing out one basic property of homology theory which does not have an obvious analog for cohomology. The property we have in mind was stated earlier as Proposition VIII.6.1. This proposition says, in essence, that for any pair (X, A) , the homology group $H_n(X, A)$ is the direct limit of the groups $H_n(C, D)$, where (C, D) ranges over all compact pairs contained in (X, A) . It is tempting to conjecture that the cohomology group $H^n(X, A; G)$ is the *inverse* limit of the groups $H^n(C, D; G)$.

However, counterexamples can be given to show that this is false. A special case of this question comes up in §3 of Appendix A.

NOTES

Surprisingly, cohomology theory was not developed until the middle 1930s about 40 years after the origin of homology theory by Poincaré. Although there were hints of cohomology theory earlier, the subject suddenly appeared on the scene in the years 1935–38. It is usual to ascribe its origin to four topologists: the Americans James W. Alexander and Hassler Whitney, the Czech Eduard Čech, and the Russian Andrei N. Kolmogoroff. References to the original papers of these four may be found in the extensive bibliography at the end of the American *Mathematical Society Colloquium*, Vol. XXVII (1942) by S. Lefschetz entitled *Algebraic Topology*.

Soon after the introduction of cohomology theory it became apparent that in many situations it was more useful than homology theory. In spite of this, many topologists resisted using it, preferring more complicated ad hoc arguments with homology theory. Part of this resistance may perhaps be ascribed to the normal resistance to any new theory. But a more fundamental reason was the greater difficulty in developing a satisfactory geometric intuition for cohomology theory, as discussed in §5 of this chapter.

References

1. W. S. Massey, *Homology and Cohomology Theory: An Approach Based on Alexander–Spanier Cochains*, Marcel Dekker, Inc., New York, 1978, Chapter 8, §8.

CHAPTER XIII

Products in Homology and Cohomology

§1. Introduction

The most important product is undoubtedly the so-called *cup product*: It assigns to any elements $u \in H^p(X; G_1)$ and $v \in H^q(X; G_2)$ an element $u \cup v \in H^{p+q}(X; G_1 \otimes G_2)$. This product is bilinear (or distributive) and is natural with respect to homomorphisms induced by continuous maps. It is an additional element of structure on the cohomology groups that often allows one to distinguish between spaces of different homotopy types, even though they have isomorphic homology and cohomology groups. This additional structure also imposes restrictions on the possible homomorphisms which can be induced by continuous maps.

Another product we shall consider is called the *cap product*. It assigns to elements $u \in H^p(X; G_1)$ and $v \in H_q(X; G_2)$ an element $u \cap v \in H_{q-p}(X; G_1 \otimes G_2)$. It is also bilinear and natural. Although the cap product is not as important as the cup product, it is needed for the statement and proof of the Poincaré duality theorem in the next chapter.

We will also consider two other products: A *cross product* which is closely related to the cup product, and a *slant product*, which has strong connections with the cap product. The main reasons for considering these two additional products is for the light they throw on the cup and cap product.

In order to make effective use of cup products, it is necessary to have ways to computing them for various spaces. Unfortunately, this is a rather difficult topic; any systematic discussion of it would be rather lengthy. In Chapter XV we will use the Poincaré duality theorem to determine cup products in projective spaces; then we can use these products to prove some interesting theorems (Borsuk–Ulam theorem, nontriviality of the Hopf maps, etc.). In the

present chapter we will mainly be concerned with a systematic discussion of the basic properties of these various products.

Because this chapter is rather long and does not have many examples, it may be best to skim through it on a first reading. Then the reader can return to it later to study more carefully the various details as they are needed.

§2. The Inner Product

In §XII.4 we defined the so-called inner product, and used it to define a natural homomorphism $\alpha: H^n(\text{Hom}(K, G)) \rightarrow \text{Hom}(H_n(K), G)$. The various naturality properties of the homomorphism α could also be interpreted as naturality properties of the inner product.

It will be convenient to generalize the definition of the inner product slightly for later use in this chapter. Let G_1 and G_2 be arbitrary abelian groups, and let K be a chain complex. Then for any elements $u \in H^q(\text{Hom}(K, G_1))$ and $v \in H_q(K \otimes G_2)$, the inner product $\langle u, x \rangle \in G_1 \otimes G_2$ is defined as follows. Choose a representative cocycle $u' \in \text{Hom}(K_q, G_1)$ for u , and a representative cycle

$$x' = \sum_{i=1}^k x_i \otimes g_i, \quad x_i \in K_q, g_i \in G_2,$$

for x . Then

$$\langle u, x \rangle = \sum_{i=1}^k u'(x_i) \otimes g_i \in G_1 \otimes G_2.$$

This more general version of the inner product has essentially the same properties as the original version.

§3. An Overall View of the Various Products

To define products, one needs to make use of the natural chain homotopy equivalences of Chapter XI,

$$\zeta: C(X) \otimes C(Y) \rightarrow C(X \times Y),$$

$$\xi: C(X \times Y) \rightarrow C(X) \otimes C(Y),$$

especially the later. We will continue to use the above notation for these chain maps, as in Chapter XI.

First, we introduce the cross product. Recall that if $f: G \rightarrow G'$ and $g: H \rightarrow H'$ are homomorphisms of abelian groups, then $f \otimes g: G \otimes H \rightarrow G' \otimes H'$ denotes the tensor product of the two homomorphisms. Using this notation, if $u \in C^p(X, G_1) = \text{Hom}(C_p(X), G_1)$ and $v \in C^q(Y, G_2) = \text{Hom}(C_q(Y), G_2)$,

then $u \otimes v \in \text{Hom}(C_p(X) \otimes C_q(Y), G_1 \otimes G_2)$. We may consider $u \otimes v$ as an element of $\text{Hom}((C(X) \otimes C(Y))_{p+q}, G_1 \otimes G_2)$ if we understand that $u \otimes v$ is the zero homomorphism on $C_i(X) \otimes C_j(Y)$, except when $i = p$ and $j = q$. Let

$$\begin{aligned} \xi^\# &= \text{Hom}(\xi, 1): \text{Hom}(C(X) \otimes C(Y), G_1 \otimes G_2) \\ &\rightarrow \text{Hom}(C(X \times Y), G_1 \otimes G_2) \\ &= C^*(X \times Y; G_1 \otimes G_2). \end{aligned}$$

Then we define $u \times v \in C^{p+q}(X \times Y; G_1 \otimes G_2)$ by

$$u \times v = \xi^\#(u \otimes v).$$

It is readily verified that

$$\delta(u \times v) = (\delta u) \times v + (-1)^p u \times \delta v.$$

From this coboundary formula, the following facts follow:

- (1) If u and v are cocycles, then so is $u \times v$.
- (2) If u_1 and u_2 are cocycles which are cohomologous, then $u_1 \times v$ and $u_2 \times v$ are cohomologous for any cocycle v .
- (3) Similarly, if v_1 and v_2 are cohomologous cocycles, then $u \times v_1$ and $u \times v_2$ are cohomologous for any cocycle u .

From these three statements it is clear that we can pass to cohomology classes, and thus define a *cross product* which assigns to any cohomology class $x \in H^p(X; G_1)$ and $y \in H^q(Y; G_2)$ a cohomology class $x \times y \in H^{p+q}(X \times Y; G_1 \otimes G_2)$. The two most important properties of this cross product are the following:

- (1) *Bilinearity.* $(x_1 + x_2) \times y = x_1 \times y + x_2 \times y$ and $x \times (y_1 + y_2) = x \times y_1 + x \times y_2$.
- (2) *Naturality.* If $f: X' \rightarrow X$ and $g: Y' \rightarrow Y$ are continuous maps, $x \in H^p(X; G_1)$ and $y \in H^q(Y; G_2)$, then

$$(f^*x) \times (g^*y) = (f \times g)^*(x \times y).$$

Later we will generalize the definition of the cross product to relative cohomology groups, and prove various additional properties.

Next, we will define the *cup product* in terms of the cross product. For any space X , let d_X or d for short, denote the diagonal map $X \rightarrow X \times X$ defined by $d(x) = (x, x)$. If $u \in H^p(X, G_1)$ and $v \in H^q(X, G_2)$, define $u \cup v \in H^{p+q}(X, G_1 \otimes G_2)$ by

$$u \cup v = d^*(u \times v).$$

We see immediately that the cup product has the following two basic properties:

- (1) *Bilinearity.* $(u_1 + u_2) \cup v = u_1 \cup v + u_2 \cup v$ and $u \cup (v_1 + v_2) = u \cup v_1 + u \cup v_2$.

(2) *Naturality.* If $f: X' \rightarrow X$ is a continuous map, $u \in H^p(X, G_1)$ and $v \in H^q(X, G_2)$, then

$$f^*(u \cup v) = (f^*u) \cup (f^*v).$$

We have just defined the cup product in terms of the cross product, using the diagonal map d . Conversely, it is possible to derive the cross product from the cup product. To clarify this point, let us assume that the cup product is given, which is bilinear and natural as just described. Define a new cross product, $u \# v$ by the formula

$$u \# v = (p_1^*u) \cup (p_2^*v)$$

for any $u \in H^p(X, G_1)$ and $v \in H^q(Y, G_2)$. Here $p_1: X \times Y \rightarrow X$ and $p_2: X \times Y \rightarrow Y$ are the projections. Then it follows easily that this new cross product is also bilinear and natural, in the same sense as the original cross product. If we use this new cross product to define a new cup product by the formula

$$u \cup' v = d^*(u \# v)$$

for any $u \in H^p(X, G_1)$ and $v \in H^q(X, G_2)$, then we find that $u \cup' v = u \cup v$, i.e., the new cup product is the same as the old. This may be proved by the following computation:

$$\begin{aligned} u \cup' v &= d^*(u \# v) = d^*((p_1^*u) \cup (p_2^*v)) \\ &= (d^*p_1^*u) \cup (d^*p_2^*v) \\ &= (p_1d)^*u \cup (p_2d)^*v = u \cup v. \end{aligned}$$

Similarly, we find that

$$\begin{aligned} u \# v &= (p_1^*u) \cup (p_2^*v) \\ &= d_{X \times Y}^*((p_1^*u) \times (p_2^*v)) \\ &= d_{X \times Y}^*(p_1 \times p_2)^*(u \times v) \\ &= [(p_1 \times p_2)d_{X \times Y}]^*(u \times v) = u \times v \end{aligned}$$

for any $u \in H^p(X, G_1)$ and $v \in H^q(Y, G_2)$.

We can reformulate what we have just proved as follows: the formulas

$$\begin{aligned} u \cup v &= d^*(u \times v), \\ u \times v &= (p_1^*u) \cup (p_2^*v) \end{aligned}$$

establish a 1–1 correspondence between cross products and cup products (which are required to be bilinear and natural).

From this point of view, the theory of cup products and the theory of cross products are logically equivalent. However, cup products are more useful, whereas cross products have a more direct and simpler definition. Later we

will consider other properties of cross and cup products, such as associativity, commutativity, and existence of a unit. We will also extend the definitions to relative cohomology groups, and consider their behavior under the coboundary operator of the exact cohomology sequence of a pair (X, A) . Naturally, the exposition of the properties of cup products will parallel that of cross products.

Remark on Terminology. Cross products are sometimes called *exterior cohomology products* and cup products are then called *interior cohomology products*.

Next, we will discuss slant products, and cap products, which are derived from slant products by means of the diagonal map.

First we define a homomorphism

$$\text{Hom}(C_p(Y), G_1) \otimes [C(X) \otimes C(Y)]_q \otimes G_2 \rightarrow C_{q-p}(X) \otimes G_1 \otimes G_2$$

denoted by $\varphi \otimes u \rightarrow \varphi \setminus u$, as follows:

$$\varphi \setminus a \otimes b \otimes g = (-1)^{|\varphi||a|} a \otimes \varphi(b) \otimes g$$

for any $\varphi \in \text{Hom}(C_p(Y), G_1)$, $a \in C(X)$, $b \in C(Y)$ and $g \in G_2$. Here the notation $|\varphi|$ means the degree of φ , $|a|$ means the degree of a , etc., and we make the convention that $\varphi(b) = 0$ unless $b \in C_p(Y)$. We can verify the formula

$$\partial(\varphi \setminus a \otimes b \otimes g) = (\delta\varphi) \setminus a \otimes b \otimes g + (-1)^{|\varphi|} \varphi \setminus \partial(a \otimes b \otimes g)$$

provided we follow the convention that

$$(\delta\varphi)(b) = (-1)^{|\varphi|} \varphi(\partial b).$$

We next define a homomorphism

$$\text{Hom}(C_p(Y), G_1) \otimes C_q(X \times Y, G_2) \rightarrow C_{q-p}(X, G_1 \otimes G_2),$$

denoted by $u \otimes v \rightarrow u \setminus v$, by using the Eilenberg–Zilber chain map ξ .

$$u \setminus v = u \setminus \xi(v).$$

Once again we have the formula

$$\partial(u \setminus v) = (\delta u) \setminus v + (-1)^{|u|} u \setminus \partial(v).$$

Hence we can pass to homology classes and get a homomorphism

$$H^p(Y, G_1) \otimes H_q(X \times Y, G_2) \rightarrow H_{q-p}(X, G_1 \otimes G_2),$$

denoted by $u \otimes v \rightarrow u \setminus v$, which is called the *slant product*. In addition to the obvious bilinearity of the slant product, it satisfies the following naturality condition: Let $f: X \rightarrow X'$ and $g: Y \rightarrow Y'$ be continuous maps. Then for any $u \in H^p(Y', G_1)$ and $v \in H_q(X \times Y, G_2)$ we have

$$f_*((g^*u) \setminus v) = u \setminus (f \times g)_* v.$$

This naturality relation can be indicated by the following diagram:

$$\begin{array}{ccccc}
 H^p(Y) \otimes H_q(X \times Y) & \longrightarrow & H_{q-p}(X) \\
 \uparrow g^* & & \downarrow f_* \\
 H^p(Y') \otimes H_q(X' \times Y') & \longrightarrow & H_{q-p}(X')
 \end{array}$$

although this is not a commutative diagram in the conventional sense.

Remark: One can reformulate the slant product so as to obtain commutative diagrams in the usual sense. Recall that there is a natural adjoint associativity isomorphism

$$\text{Hom}(B \otimes A, C) \approx \text{Hom}(A, \text{Hom}(B, C))$$

for any abelian groups $A, B,$ and $C.$ Thus, we can consider the slant product as a homomorphism

$$H_q(X \times Y) \rightarrow \text{Hom}(H^p(Y), H_{q-p}(X)).$$

Then the naturality condition gives rise to the following diagram, which is commutative in the usual sense:

$$\begin{array}{ccc}
 H_q(X \times Y) & \longrightarrow & \text{Hom}(H^p(Y), H_{q-p}(X)) \\
 \downarrow (f \times g)_* & & \downarrow \text{Hom}(f^*, g_*) \\
 H_q(X' \times Y') & \longrightarrow & \text{Hom}(H^p(Y'), H_{q-p}(X'))
 \end{array}$$

However, most people find this formulation of the slant product rather awkward to work with.

We can now define the cap product. It is a homomorphism

$$H^p(X, G_1) \otimes H_q(X, G_2) \rightarrow H_{q-p}(X, G_1 \otimes G_2),$$

denoted by $u \otimes v \rightarrow u \cap v,$ and defined by

$$u \cap v = u \searrow d_*(v)$$

where $d : X \rightarrow X \times X$ is the diagonal map. It is bilinear and natural in the following sense. Let $f : X \rightarrow X'$ be a continuous map. Then for any $u \in H^p(X'),$ $v \in H_q(X)$ we have

$$f_*((f^*u) \cap v) = u \cap f_*v.$$

The corresponding diagram is the following:

$$\begin{array}{ccc}
 H^p(X) \otimes H_q(X) & \xrightarrow{\cap} & H_{q-p}(X) \\
 \uparrow f^* & & \downarrow f_* \\
 H^p(X') \otimes H_q(X') & \xrightarrow{\cap} & H_{q-p}(X')
 \end{array}$$

Once again, this could be made into a conventional commutative diagram by using the Hom functor rather than \otimes .

We have just shown how to derive the cap product from the slant product. Conversely, the slant product can be derived from the cap product, as follows. For any $u \in H^p(Y, G_1)$ and $v \in H_q(X \times Y, G_2)$, define

$$u \setminus v = p_{1*}((p_2^*u) \cap v),$$

where p_1 and p_2 are the projections of $X \times Y$ on the first and second factors, respectively. By the same methods used in the discussion of cross and cup products, one can prove that our formulas establish a 1–1 correspondence between slant and cap products (which are required to be natural and to be bilinear). Thus, the theories of these two different kinds of products should be logically equivalent. Actually, cap products will be needed in our discussion of the Poincaré duality theorem for manifolds; however, the definition of slant products is a bit simpler.

Remark. We have based our discussion of the cup and can product on the use of the Eilenberg–Zilber natural chain homotopy equivalence

$$\xi : C(X \times Y) \rightarrow C(X) \otimes C(Y)$$

together with the diagonal map $d : X \rightarrow X \otimes X$. An alternative procedure would be to use natural diagonal maps $\Delta^X : C(X) \rightarrow C(X) \otimes C(X)$ as described in Exercise XI.5.2. For the connection between ξ and Δ , see Exercise XI.5.3. The choice of which method to use is largely a matter of taste. However, there is some advantage to having both cross and cup products, and the relationship between them.

§4. Extension of the Definition of the Various Products to Relative Homology and Cohomology Groups

The main difficulty in extending cross and slant products to relative cohomology and homology groups is the problem of extending the Eilenberg–Zilber chain homotopy equivalence ξ to relative groups; this problem was already encountered in the discussion in §XI.6 of the homology groups of product spaces. The main result of that discussion may be summarized as follows: Let (X, A) and (Y, B) be pairs. Then the chain map ξ induces a chain homotopy equivalence

$$\frac{C(X)}{C(A)} \otimes \frac{C(Y)}{C(B)} \xleftarrow{\xi} \frac{C(X \times Y)}{C(X \times B) + C(A \times Y)}.$$

If we assume that $\{X \times B, A \times Y\}$ is an excisive couple in $X \times Y$, then the homomorphism

$$k: \frac{C(X \times Y)}{C(X \times B) + C(A \times Y)} \rightarrow \frac{C(X \times Y)}{C(X \times B \cup A \times Y)}$$

induces isomorphisms on homology and cohomology with any coefficients.

In view of this, when we want to define cross or slant products in the homology and/or cohomology of pairs (X, A) and (Y, B) , we will always assume that $\{X \times B, A \times Y\}$ is an excisive couple in $X \times Y$. With this added assumption, our previous definitions generalize very easily. The details are as follows.

Cross Product. If $u \in C^p(X, A; G_1) = \text{Hom}(C_p(X)/C_p(A), G_1)$ and $v \in C^q(Y, B; G_2) = \text{Hom}(C_q(Y)/C_q(B), G_2)$, then

$$\begin{aligned} u \otimes v &\in \text{Hom} \left(\left(\frac{C(X)}{C(A)} \otimes \frac{C(Y)}{C(B)} \right)_{p+q}, G_1 \otimes G_2 \right) \\ &= \text{Hom} \left(\left(\frac{C(X) \otimes C(Y)}{C(X) \otimes C(B) + C(A) \otimes C(Y)} \right)_{p+q}, G_1 \otimes G_2 \right) \end{aligned}$$

and

$$\xi^\#(u \otimes v) \in \text{Hom} \left(\left(\frac{C(X \times Y)}{C(X \times B) + C(A \times Y)} \right)_{p+q}, G_1 \otimes G_2 \right).$$

Passing to cohomology groups, and applying the isomorphism $(k^*)^{-1}$, we obtain the cross product in cohomology, which is a homomorphism

$$H^p(X, A; G_1) \otimes H^q(Y, B; G_2) \xrightarrow{\times} H^{p+q}(X \times Y; A \times Y \cup X \times B; G_1 \otimes G_2).$$

The *naturality condition* now reads as follows: Let $f: (X, A) \rightarrow (X', A')$ and $g: (Y, B) \rightarrow (Y', B')$ be continuous maps of pairs. Then the following diagram is commutative:

$$\begin{array}{ccc} H^p(X', A') \otimes H^q(Y', B') & \xrightarrow{\times} & H^{p+q}(X' \times Y', A' \times Y' \cup X' \times B') \\ \downarrow f^* \otimes g^* & & \downarrow (f \times g)^* \\ H^p(X, A) \otimes H^q(Y, B) & \xrightarrow{\times} & H^{p+q}(X \times Y, A \times Y \cup X \times B) \end{array}$$

In symbols,

$$(f^*u) \times (g^*v) = (f \times g)^*(u \times v)$$

for any $u \in H^p(X', A'; G_1)$ and $v \in H^q(Y', B'; G_2)$. It is assumed, of course, that $\{A \times Y, X \times B\}$ and $\{A' \times Y', X' \times B'\}$ are excisive couples.

Slant Product. First, one defines the homomorphism

$$\text{Hom} \left(\frac{C_p(Y)}{C^p(B)}, G_1 \right) \otimes \left[\frac{C(X)}{C(A)} \otimes \frac{C(Y)}{C(B)} \right]_q \otimes G_2 \rightarrow \frac{C_{q-p}(X)}{C_{q-p}(A)} \otimes G_1 \otimes G_2,$$

denoted by $\varphi \otimes u \rightarrow \varphi \backslash u$, by the formula

$$\varphi \setminus \setminus a \otimes b \otimes g = (-1)^{|\varphi||a|} a \otimes \varphi(b) \otimes g$$

exactly as in §3. Then one defines a homomorphism

$$\text{Hom}\left(\frac{C_p(Y)}{C_p(B)}, G_1\right) \otimes \frac{C_q(X \times Y)}{C_q(A \times Y) + C_q(X \times B)} \otimes G_2 \rightarrow C_{q-p}(X, A; G_1 \otimes G_2),$$

denoted by $\varphi \otimes u \rightarrow \varphi \setminus u$, by the formula

$$\varphi \setminus u = \varphi \setminus \setminus \xi(u).$$

Passing to homology and cohomology, and using the isomorphism $(k_*)^{-1}$, we obtain the *slant product*, a homomorphism

$$H^p(Y, B; G_1) \otimes H_q(X \times Y; A \times Y \cup X \times B; G_2) \rightarrow H_{q-p}(X, A; G_1 \otimes G_2)$$

which is denoted by $u \otimes v \rightarrow u \setminus v$. The *naturality* condition is expressed by the following diagram:

$$\begin{array}{ccc} H^p(Y', B') \otimes H_q(X' \times Y', A' \times Y' \cup X' \times B') & \longrightarrow & H_{q-p}(X', A') \\ \downarrow g^* & \uparrow (f \times g)_* & \uparrow f_* \\ H^p(Y, B) \otimes H_q(X \times Y, A \times Y \cup X \times B) & \longrightarrow & H_{q-p}(X, A) \end{array}$$

Here $f: (X, A) \rightarrow (X', A')$ and $g: (Y, B) \rightarrow (Y', B')$ are continuous maps of pairs, and it is assumed that $\{A \times Y, X \times B\}$ and $\{A' \times Y', X' \times B'\}$ are excisive couples.

We will now take up the problem of defining the cup and cap product for relative cohomology and homology groups. Here the situation is slightly different. For the cup product, the object is to define a homomorphism

$$H^p(X, A; G_1) \otimes H^q(X, B; G_2) \xrightarrow{\cup} H^{p+q}(X, A \cup B; G_1 \otimes G_2)$$

under a reasonable set of assumptions; and for the cap product, one wishes to define a homomorphism

$$H^p(X, A; G_1) \otimes H_q(X, A \cup B; G_2) \rightarrow H_{q-p}(X, B; G_1 \otimes G_2)$$

under minimal hypotheses. The cup product will be defined from the cross product, and the cap product will be defined from the slant product by use of the diagonal map $d: X \rightarrow X \times X$.

Cup Products. Let us consider a triad $(X; A, B)$ consisting of a topological space X and arbitrary subspaces A and B . We have the following two chain maps, induced by obvious inclusions:

$$k: \frac{C(X \times X)}{C(A \times X) + C(X \times B)} \rightarrow \frac{C(X \times X)}{C(A \times X \cup X \times B)},$$

$$l: \frac{C(X)}{C(A) + C(B)} \rightarrow \frac{C(X)}{C(A \cup B)}.$$

If we attempt to define the cup product using the cross product and the diagonal map, we are led to the following commutative diagram:

$$\begin{array}{ccc}
 H^p(X, A) \otimes H^q(X, B) & & \\
 \downarrow \times & & \\
 H^{p+q} \left(\text{Hom} \left(\frac{C(X \times X)}{C(A \times X) + C(X \times B)}, G_1 \otimes G_2 \right) \right) & \xrightarrow{d_1^*} & H^{p+q} \left(\text{Hom} \left(\frac{C(X)}{C(A) + C(B)}, G_1 \otimes G_2 \right) \right) \\
 \uparrow k^* & & \uparrow l^* \\
 H^{p+q}(X \times X, X \times B \cup A \times X; G_1 \otimes G_2) & \xrightarrow{d_2^*} & H^{p+q}(X, A \cup B; G_1 \otimes G_2).
 \end{array}$$

Here d_1^* and d_2^* are induced by the diagonal map $d: X \rightarrow X \times X$. From this diagram it is clear that to define cup products, we may either assume that $\{A \times X, X \times B\}$ is an excisive couple, in which case k^* will be an isomorphism, or we may assume that $\{A, B\}$ is an excisive couple in X , in which case l^* will be an isomorphism. It is preferable and customary to make the latter assumption for a couple of reasons. First of all in the important special case $A = B$, $\{A, B\}$ is always an excisive couple, whereas $\{A \times X, X \times B\}$ need not be excisive (as far as is known). Second, for some of our later results about cup products, we will need to assume that $\{A, B\}$ is an excisive couple in X for other reasons. Thus, we may as well assume it is excisive at the beginning. Therefore, *in order to define cup products*

$$H^p(X, A) \otimes H^q(X, B) \xrightarrow{\cup} H^{p+q}(X, A \cup B)$$

we will always assume that $\{A, B\}$ is an excisive couple in X . This has the following slight disadvantage: In order to have the relation

$$u \cup v = d^*(u \times v)$$

hold true, it is necessary to assume that *both* $\{A, B\}$ and $\{X \times B, A \times X\}$ are excisive couples.

Cap Product. The discussion is analogous to that just given for the cup product. Let A and B be arbitrary subsets of X ; then we have the following commutative diagram:

$$\begin{array}{ccc}
 H^p(X, A; G_1) \otimes H_q \left(\frac{C(X \times X)}{C(X \times B \cup A \times X)} \otimes G_2 \right) & \xleftarrow{1 \otimes d_{2*}} & H^p(X, A; G_1) \otimes H_q \left(\frac{C(X)}{C(A \cup B)} \otimes G_2 \right) \\
 \uparrow 1 \otimes k_* & & \uparrow 1 \otimes l_* \\
 H^p(X, A; G_1) \otimes H_q \left(\frac{C(X \times X)}{C(X \times B) + C(A \times X)} \otimes G_2 \right) & \xleftarrow{1 \otimes d_{1*}} & H^p(X, A; G_1) \otimes H_q \left(\frac{C(X)}{C(A) + C(B)} \otimes G_2 \right) \\
 \searrow \text{slant product} & & \swarrow \text{cap product} \\
 & & H_{q-p}(X, B; G_1 \otimes G_2)
 \end{array}$$

This diagram is entirely analogous to the preceding one, and the symbols for the various maps have the same meaning. In order to *define the cap product*, we will assume that $\{A, B\}$ is an excisive couple in X . Then the cap product is a homomorphism

$$H^p(X, A; G_1) \otimes H_q(X, A \cup B; G_2) \xrightarrow{\cap} H_{q-p}(X, B; G_1 \otimes G_2)$$

which is the composition of $(1 \otimes l_*)^{-1}$, $1 \otimes d_{1*}$, and the slant product in the above diagram. If in addition we assume that $\{X \times B, A \times X\}$ is an excisive couple in $X \times X$, then the following relation holds between the slant and cap products:

$$u \cap v = u \setminus (d_{2*} v).$$

§5. Associativity, Commutativity, and Existence of a Unit for the Various Products

In order to discuss these questions, it is necessary to discuss the associativity, commutativity, and existence of a unit for the Eilenberg–Zilber chain homotopy equivalence $\xi : C(X \times Y) \rightarrow C(X) \otimes C(Y)$. In order to discuss the associativity of ξ , consider the following diagram:

$$\begin{array}{ccc} C(X \times Y \times Z) & \xrightarrow{\xi^{X \times Y, Z}} & C(X \times Y) \otimes C(Z) \\ \downarrow \xi^{X, Y \times Z} & & \downarrow \xi^{X, Y} \otimes 1 \\ C(X) \otimes C(Y \times Z) & \xrightarrow{1 \otimes \xi^{Y, Z}} & C(X) \otimes C(Y) \otimes C(Z) \end{array}$$

Recall that the proof of the existence of the chain map ξ required the choice of a certain chain $e_n \in [C(I^n) \otimes C(I^n)]_n$ for each positive integer n . It is too much to expect that the above diagram would be commutative for an arbitrarily constructed chain map ξ . However, using the method of acyclic models, it is easy to prove that the two different chain maps in this diagram from $C(X \times Y \times Z)$ to $C(X) \otimes C(Y) \otimes C(Z)$ are chain homotopic (in fact, by a *natural* chain homotopy). Hence on passage to homology we *do* obtain a commutative diagram.

EXERCISES

- 5.1. Prove that the natural chain map $\eta : C(X \times Y) \rightarrow C(X) \otimes C(Y)$ (explicitly defined in §XI.5) is associative, i.e., if it is substituted for ξ in the diagram above, one obtains a commutative diagram.
- 5.2. Prove that the natural chain map $\zeta : C(X) \otimes C(Y) \rightarrow C(X \times Y)$ defined in §XI.3 is associative (in the sense discussed above).

In order to discuss the commutativity of ξ , consider the following diagram:

$$\begin{array}{ccc} C(X \times Y) & \xrightarrow{\xi^{X, Y}} & C(X) \otimes C(Y) \\ \downarrow t_* & & \downarrow T \\ C(Y \times X) & \xrightarrow{\xi^{Y, X}} & C(Y) \otimes C(X) \end{array}$$

In this diagram, $t: X \times Y \rightarrow Y \times X$ is defined by $t(x, y) = (y, x)$, and T is defined by

$$T(a \otimes b) = (-1)^{p_a} b \otimes a$$

for any $a \in C_p(X)$ and $b \in C_q(Y)$. It is readily checked that T is a chain map. Therefore, $T\xi^{X,Y}$ and $\xi^{Y,X}t_{\#}$ are both natural chain maps $C(X \times Y) \rightarrow C(Y) \otimes C(X)$, and by the method of acyclic models they can be proven chain homotopic (by a natural chain homotopy). It is interesting to note that there is one rather important difference between the question of the associativity and the question of the commutativity of ξ : As we saw in Exercise 5.1, it is possible to choose ξ so that it will be associative. However, it is known that it is *not* possible to choose a natural chain map ξ which is commutative. This follows from the fact that the Steenrod squaring operations exist and are nonzero (see Exercise XI.5.4 and the reference to Spanier's book given there). This is one of the mysterious "facts of life" in algebraic topology.

Next we will discuss the property of the Eilenberg–Zilber map ξ that guarantees the existence of units for cross and cup products. For this purpose, let us regard the additive group of integers \mathbf{Z} as a chain complex which is "concentrated in degree 0," i.e., as a chain complex C such that $C_0 = \mathbf{Z}$, and $C_q = 0$ for $q \neq 0$. Then the augmentation $\varepsilon: C_0(X) \rightarrow \mathbf{Z}$ can be looked on as a chain map $\varepsilon: C(X) \rightarrow \mathbf{Z}$. With these conventions, consider the following two diagrams:

$$\begin{array}{ccc} C(X \times Y) & \xrightarrow{P_{1\#}} & C(X) \\ \downarrow \xi^{X,Y} & & \parallel \\ C(X) \otimes C(Y) & \xrightarrow{1 \otimes \varepsilon} & C(X) \otimes \mathbf{Z} \end{array} \qquad \begin{array}{ccc} C(X \times Y) & \xrightarrow{P_{2\#}} & C(Y) \\ \downarrow \xi^{X,Y} & & \parallel \\ C(X) \otimes C(Y) & \xrightarrow{\varepsilon \otimes 1} & \mathbf{Z} \otimes C(Y) \end{array}$$

Once again, by the use of acyclic models it can be proved that these two diagrams are homotopy commutative, (In these diagrams $p_1: X \times Y \rightarrow X$ and $p_2: X \times Y \rightarrow Y$ denote projections on the first and second factors respectively.)

EXERCISES

- 5.3. Verify that if we substitute the explicit map η defined in §XI.5 for ξ in the above diagrams, they become commutative.

With these preliminaries out of the way, we can state our various associative laws, commutative laws, etc. The verifications of these properties will be left to the reader for the most part. First we will list the various associative laws.

Associative Law for Cross Products. Let $u \in H^p(X, A; G_1)$, $v \in H^q(Y, B; G_2)$, and $w \in H^r(Z, C; G_3)$. Then

$$u \times (v \times w) = (u \times v) \times w$$

provided enough couples are assumed excisive to insure that all \times -products are defined.

Associative Law for Cup Products. Let $u \in H^p(X, A; G_1)$, $v \in H^q(X, B; G_2)$ and $w \in H^r(X, C; G_3)$. Then

$$u \cup (v \cup w) = (u \cup v) \cup w$$

provided enough couples in X are assumed excisive for everything to be well defined.

Associative Law for Slant Products. Let $u \in H^p(Y, B; G_1)$, $v \in H^q(Z, C; G_2)$ and $w \in H_r((X, A) \times (Y, B) \times (Z, C); G_3)$, where we set

$$(X, A) \times (Y, B) = (X \times Y, X \times B \cup A \times Y)$$

etc., for the sake of brevity. Then

$$(u \times v) \setminus w = u \setminus (v \setminus w),$$

provided enough couples in the various product spaces are assumed excisive so that everything is well defined.

Associative Law for Cap Products. Assume that $u \in H^p(X, A; G_1)$, $v \in H^q(X, B; G_2)$, and $w \in H_r(X, A \cup B \cup C; G_3)$. Then

$$(u \cap v) \cap w = u \cap (v \cap w)$$

in $H_{r-p-q}(X, C; G_1 \otimes G_2 \otimes G_3)$, provided $\{A, B\}$, $\{B, A \cup C\}$, $\{A \cup B, C\}$, and $\{A, C\}$ are excisive couples in X .

The fact that one has to make so many awkward assumptions about excisive couples in order to state an associative law must be considered a defect of singular homology and cohomology theory. Fortunately, in practice one does not usually have trouble about this because it will be clear from the context in many cases, that all the couples involved are automatically excisive. This will be true if all the subspaces are open sets, or if all are subcomplexes of CW-complexes, for example.

Next, we will take up the commutative laws.

Commutative Law for Cross Products. Let $u \in H^p(X, A; G_1)$ and $v \in H^q(Y, B; G_2)$. Then

$$t^*(u \times v) = (-1)^{pq} v \times u,$$

where $t: (Y, B) \times (X, A) \rightarrow (X, A) \times (Y, B)$ is defined by $t(y, x) = (x, y)$. Of course, one must assume that $\{X \times B, A \times Y\}$ is an excisive couple.

Commutative Law for Cup Products. Let $u \in H^p(X, A; G_1)$ and $v \in H^q(X, B; G_2)$. Then

$$u \cup v = (-1)^{pq} v \cup u$$

provided $\{A, B\}$ is an excisive couple.

There is no commutative law for slant or cap products; they do not lend themselves to any such law. This is *not* to say that the homotopy commutativity of the Eilenberg–Zilber chain homotopy equivalence ξ does not affect these products, however.

Existence of Units. For any space X , the augmentation $\varepsilon : C_0(X) \rightarrow \mathbf{Z}$ may be considered to be a 0-cochain, which is a cocycle. We will denote its cohomology class by $1 \in H^0(X; \mathbf{Z})$, or 1_X to be more explicit. For cross products, we have the following equations:

$$u \times 1_Y = p_1^*(u), \quad u \in H^p(X, A; G),$$

$$1_X \times v = p_2^*(v), \quad v \in H^q(Y, B; G).$$

In these equations, p_1 and p_2 denote the projections on the first and second factors of the product space, as usual.

For cup products, the equations are even simpler: for any $u \in H^p(X, A; G)$,

$$1_X \cup u = u \cup 1_X = u.$$

For slant products, we have

$$1_Y \setminus v = p_{1*}(v)$$

for any $v \in H_q(X \times Y; A \times Y; G)$ whereas for cap products,

$$1_X \cap v = v$$

for any $v \in H_q(X, B; G)$.

Note that 1_X acts as both a left and right unit for cross and cup products, whereas for slant and cap products, we have only a left unit. Also note that there is *no* unit in $H^0(X, A)$ if A is nonempty.

§6. Digression: The Exact Sequence of a Triple or a Triad

In order to describe in a most concise way the behavior of the various products with respect to the boundary operator $\partial_* : H_q(X, A) \rightarrow H_{q-1}(A)$ or the co-boundary operator $\delta^* : H^p(A) \rightarrow H^{p+1}(X, A)$, it is convenient to make use of the exact homology (or cohomology) sequence of a triad.

First, let (X, A, B) be a *triple*, i.e., X is a topological space, and $X \supset A \supset B$. Then we have the following split exact sequence of chain complexes:

$$0 \rightarrow C(A, B) \xrightarrow{i^*} C(X, B) \xrightarrow{j^*} C(X, A) \rightarrow 0.$$

Since this sequence is split exact, if we apply the functor $\otimes G$ or $\text{Hom}(\ , G)$, we again obtain a short exact sequence of chain or cochain complexes. We may then pass to the corresponding long exact homology and cohomology

sequences:

$$\begin{aligned} \cdots \xrightarrow{\partial_*} H_q(A, B; G) \xrightarrow{i_*} H_q(X, B; G) \xrightarrow{j_*} H_q(X, A; G) \xrightarrow{\partial_*} H_{q-1}(A, B; G) \rightarrow \cdots, \\ \cdots \xleftarrow{\delta^*} H^q(A, B; G) \xleftarrow{i^*} H^q(X, B; G) \xleftarrow{j^*} H^q(X, A; G) \xleftarrow{\delta^*} H^{q-1}(A, B; G) \leftarrow \cdots. \end{aligned}$$

Note: The exact homology or cohomology sequence of a triple can also be derived directly from the basic concepts of singular homology theory, without going back to chain complexes; cf. Eilenberg and Steenrod, [2, Chapter I, §10].

Next, let $(X; A, B)$ be a *triad*, i.e., A and B are arbitrary subsets of X (no inclusion relations are assumed between A and B). Assume that $\{A, B\}$ is an excisive couple in X ; it follows that the inclusion maps

$$\begin{aligned} k_1 : (A, A \cap B) &\rightarrow (A \cup B, B), \\ k_2 : (B, A \cap B) &\rightarrow (A \cup B, A) \end{aligned}$$

induce isomorphisms on homology and cohomology groups with any coefficients. If we substitute the (co-) homology groups of $(A, A \cap B)$ for those of $(A \cup B, B)$ in the exact (co-) homology sequence of the triple $(X, A \cup B, B)$, (using the isomorphism induced by k_1), we obtain one of the (co-) homology sequences of the triad $(X; A, B)$. To obtain the other (co-) homology sequence of this triad, use the isomorphism induced by k_2 to substitute the (co-) homology groups of $(B, A \cap B)$ for those of $(A \cup B, A)$ in the exact (co-) homology sequence of the triple $(X, A \cup B, A)$. The resulting homology sequences are as follows:

$$\begin{aligned} \cdots \xrightarrow{\Delta_*} H_n(A, A \cap B) \rightarrow H_n(X, B) \rightarrow H_n(X, A \cup B) \xrightarrow{\Delta_*} H_{n-1}(A, A \cap B) \cdots, \\ \cdots \xrightarrow{\Delta_*} H_n(B, A \cap B) \rightarrow H_n(X, A) \rightarrow H_n(X, A \cup B) \xrightarrow{\Delta_*} H_{n-1}(B, A \cap B) \cdots. \end{aligned}$$

The coefficient group has been omitted from the notation. The homomorphisms Δ_* will be referred to as *the boundary operators of the triad* $(X; A, B)$; they are defined so as to make the following two diagrams commutative:

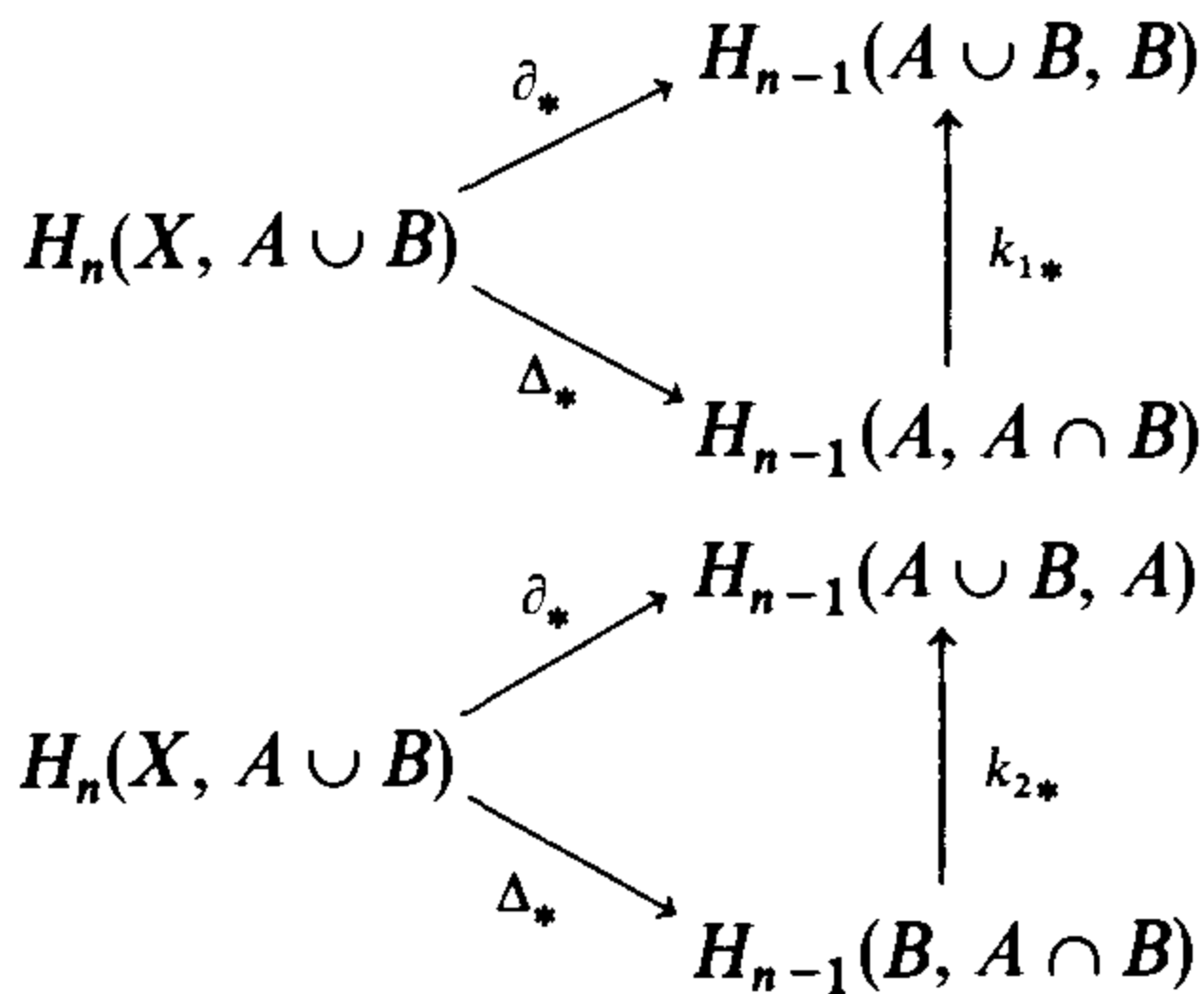

Analogously, we will denote the coboundary operators of the exact cohomology sequences of this triad as follows:

$$\Delta^* : H^{n-1}(A, A \cap B) \rightarrow H^n(X, A \cup B),$$

$$\Delta^* : H^{n-1}(B, A \cap B) \rightarrow H^n(X, A \cup B).$$

We have introduced the exact homology and cohomology sequences of a triad for a very specific purpose in connection with the various products. However, these exact sequences, and the exact sequence of a triple, are of interest in their own right.

There is one other exact sequence which it is convenient to introduce now, known as the *relative Mayer–Vietoris sequence*. It will be needed in Chapter XIV. Let $(X; A, B)$ be a triad, and assume that $\{A, B\}$ is an excisive couple in X . We will use the following notation for inclusion maps:

$$i : (X, A \cap B) \rightarrow (X, A),$$

$$j : (X, A \cap B) \rightarrow (X, B),$$

$$k : (X, A) \rightarrow (X, A \cup B),$$

$$l : (X, B) \rightarrow (X, A \cup B).$$

Consider the following sequence of chain complexes and chain maps:

$$0 \rightarrow C(X, A \cap B) \xrightarrow{\Phi} C(X, A) \oplus C(X, B) \xrightarrow{\Psi} \frac{C(X)}{C(A) + C(B)} \rightarrow 0.$$

Here the chain maps Φ and ψ are defined as follows:

$$\Phi(x) = (i_{\#} x, j_{\#} x),$$

$$\Psi(u, v) = k_{\#}(u) - l_{\#}(v).$$

It is not difficult to prove that this sequence is exact; in fact, it is even split exact because all the chain complexes consist of free abelian groups. If we pass to the corresponding long exact homology sequence and substitute $C(X, A \cup B)$ for $C(X)/[C(A) + C(B)]$, we obtain the relative Mayer–Vietoris sequence of the triad $(X; A, B)$:

$$\begin{aligned} \cdots \rightarrow H_n(X, A \cap B) \xrightarrow{\varphi} H_n(X, A) \oplus H_n(X, B) \xrightarrow{\psi} H_n(X, A \cup B) \\ \xrightarrow{\Delta} H_{n-1}(X, A \cap B) \xrightarrow{\varphi} \cdots \end{aligned}$$

Of course, there is a dual exact sequence of cohomology groups.

§7. Behavior of Products with Respect to the Boundary and Coboundary Operator of a Pair

We will content ourselves with stating the main properties involved, leaving the proofs to the reader.

(a) *Cross Products*. Assume that (X, A) and (Y, B) are pairs such that

$\{A \times Y, X \times B\}$ is an excisive couple. Then the following two diagrams are commutative:

$$\begin{array}{ccc}
 H^p(A) \otimes H^q(Y, B) & \xrightarrow{\times} & H^{p+q}(A \times Y, A \times B) \\
 \downarrow \delta^* \otimes 1 & & \downarrow \Delta_* \\
 H^{p+1}(X, A) \otimes H^q(Y, B) & \xrightarrow{\times} & H^{p+q+1}(X \times Y, X \times B \cup A \times Y) \\
 \\
 H^p(X, A) \otimes H^q(B) & \xrightarrow{\times} & H^{p+q}(X \times B, A \times B) \\
 \downarrow (-1)^p \otimes \delta^* & & \downarrow \Delta^* \\
 H^p(X, A) \otimes H^{q+1}(Y, B) & \xrightarrow{\times} & H^{p+q+1}(X \times Y, X \times B \cup A \times Y)
 \end{array}$$

These two relations may also be expressed by equations as follows: For any $u \in H^p(A)$ and $v \in H^q(Y, B)$,

$$(\delta^*u) \times v = \Delta^*(u \times v).$$

For any $u \in H^p(X, A)$ and $v \in H^q(B)$,

$$(-1)^p(u \times \delta^*v) = \Delta^*(u \times v).$$

Obviously, the second relation can be derived from the first by use of the commutative law.

(b) *Cup Products.* Assume that $\{A, B\}$ is an excisive couple in X . Then we have the following two diagrams to describe the relations involved (they are not commutative diagrams in the usual sense; cf. the discussion of naturality of the slant and cap products).

$$\begin{array}{ccc}
 H^p(A) \otimes H^q(A, A \cap B) & \xrightarrow{\cup} & H^{p+q}(A, A \cap B) \\
 \delta^* \downarrow & & \uparrow k^* \\
 H^{p+1}(X, A) \otimes H^q(X, B) & \xrightarrow{\cup} & H^{p+q+1}(X, A \cup B) \\
 \\
 H^p(B, A \cap B) \otimes H^q(B) & \xrightarrow{\cup} & H^{p+q}(B, A \cap B) \\
 \uparrow l^* & & \downarrow \delta^* \\
 H^p(X, A) \otimes H^{q+1}(X, B) & \xrightarrow{\cup} & H^{p+q+1}(X, A \cup B)
 \end{array}$$

These relations may also be stated in equations as follows. If $u \in H^p(A)$ and $v \in H^q(X, B)$, then

$$(\delta^*u) \cup v = \Delta^*(u \cup k^*v).$$

For the second relation, if $u \in H^p(X, A)$ and $v \in H^q(B)$, then

$$(-1)^p u \cup \delta^*v = \Delta^*((l^*u) \cup v).$$

EXERCISES

7.1. Under the above assumptions, prove that we have the following commutative diagram:

$$\begin{array}{ccccccc}
 H^p(X, A) & \xrightarrow{j^*} & H^p(X) & \xrightarrow{i^*} & H^p(A) & \xrightarrow{\partial^*} & H^{p+1}(X, A) \\
 \downarrow \cup v & & \downarrow \cup v & & \downarrow \cup k^*v & & \downarrow \\
 H^{p+q}(X, A \cup B) & \longrightarrow & H^{p+q}(X, B) & \longrightarrow & H^{p+q}(A, A \cap B) & \xrightarrow{\Delta^*} & H^{p+q+1}(X, A \cup B).
 \end{array}$$

Here $v \in H^q(X, B)$.

(c) *Slant Products*. Assume, as in (a), that (X, A) and (Y, B) are pairs such that $\{X \times B, A \times Y\}$ is an excisive couple. Then the relations are expressed by the following two diagrams of which the first is a commutative diagram in the usual sense:

$$\begin{array}{ccc}
 H^p(Y, B) \otimes H_q(X \times Y, A \times Y \cup X \times B) & \xrightarrow{\text{slant}} & H_{q-p}(X, A) \\
 \downarrow (-1)^p \otimes \Delta_* & & \downarrow \partial_* \\
 H^p(Y, B) \otimes H_{q-1}(A \times Y, A \times B) & \xrightarrow{\text{slant}} & H_{q-p-1}(A) \\
 \\
 H^p(Y, B) \otimes H_q(X \times Y, A \times Y \cup X \times B) & \xrightarrow{\text{slant}} & H_{q-p}(X, A) \\
 \uparrow \delta^* & \searrow & \uparrow (-1)^p \\
 H^{p-1}(B) \otimes H_{q-1}(X \times B, A \times B) & \xrightarrow{\text{slant}} & H_{q-p}(X, A) \\
 & \swarrow & \downarrow \Delta_*
 \end{array}$$

The second diagram expresses the fact that the homomorphisms δ^* and Δ_* are adjoint in a certain sense. These relations may be expressed in equations as follows: Let $u \in H^p(Y, B)$ and $v \in H_q(X \times Y, A \times Y \cup X \times B)$. Then

$$\partial_*(u \setminus v) = (-1)^p u \setminus \Delta_* v.$$

For the second relation, let $u \in H^{p-1}(B)$ and $v \in H_q(X \times Y, A \times Y \cup X \times B)$. Then

$$(\delta^* u) \setminus v + (-1)^{p-1} u \setminus \Delta_* v = 0.$$

(d) *Cap Products*. Assume that $\{A, B\}$ is an excisive couple in X . Then the following diagram is commutative, up to the sign $(-1)^p$:

$$\begin{array}{ccc}
 H^p(X, A) \otimes H_q(X, A \cup B) & \xrightarrow{\cap} & H_{q-p}(X, B) \\
 \downarrow k^* \otimes \Delta_* & & \downarrow \partial_* \\
 H^p(B, A \cap B) \otimes H_{q-1}(B, A \cap B) & \xrightarrow{\cap} & H_{q-p-1}(B)
 \end{array}$$

This relation may be expressed by the following equation:

$$(-1)^p(k^*u) \cap (\Delta_*v) = \partial_*(u \cap v)$$

for any $u \in H^p(X, A)$ and $v \in H_q(X, A \cup B)$. A second relation is indicated by the following diagram:

$$\begin{array}{ccc} H^p(X, A) \otimes H_q(X, A \cup B) & \longrightarrow & H_{q-p}(X, B) \\ \uparrow \delta^* & & \uparrow k_* \\ H^{p-1}(A) \otimes H_{q-1}(A, A \cap B) & \longrightarrow & H_{q-p}(A, A \cap B) \end{array} \quad (-1)^p \Delta_*$$

Equivalently,

$$(\delta^*u) \cap v + (-1)^{p-1}k_*(u \cap \Delta_*v) = 0$$

for any $u \in H^{p-1}(A)$ and any $v \in H_q(X, A \cup B)$.

EXERCISES

7.2. Prove that the following diagram is commutative:

$$\begin{array}{ccccccc} H_q(B, A \cap B) & \longrightarrow & H_q(X, A) & \longrightarrow & H_q(X, A \cup B) & \xrightarrow{\Delta_*} & H_{q-1}(B, A \cap B) \\ \downarrow (k^*u) \cap & & \downarrow u \cap & & \downarrow u \cap & (-1)^p & \downarrow (k^*u) \cap \\ H_{q-p}(B) & \longrightarrow & H_{q-p}(X) & \longrightarrow & H_{q-p}(X, B) & \xrightarrow{\partial_*} & H_{q-p-1}(B) \end{array}$$

Here $u \in H^p(X, A)$.

7.3. Prove that corresponding homomorphisms in the following two exact sequences are “adjoints” of each other, with respect to the indicated cap product:

$$\begin{array}{ccccccc} H^p(A) & \longleftarrow & H^p(X) & \longleftarrow & H^p(X, A) & \xleftarrow{\delta^*} & H^{p-1}(A) \\ \otimes & & \otimes & & \otimes & & \otimes \\ H_q(A, A \cap B) & \longrightarrow & H_q(X, B) & \longrightarrow & H_q(X, A \cup B) & \longrightarrow & H_{q-1}(A, A \cap B) \\ \downarrow \cap & & \downarrow \cap & & \downarrow \cap & & \downarrow \cap \\ H_{q-p}(A, A \cap B) & \longrightarrow & H_{q-p}(X, B) & = & H_{q-p}(X, B) & \longleftarrow & H_{q-p}(A, A \cap B). \end{array}$$

§8. Relations Involving the Inner Product

These relations involve the inner product, which was defined in §2, and the cross, slant, cup, and cap products.

(a) Assume that (X, A) and (Y, B) are pairs such that $\{A \times Y, X \times B\}$ is an excisive couple in $X \times Y$. In Chapter XI we defined the homomorphism

$$\alpha : H_p(X, A) \otimes H_q(Y, B) \rightarrow H_{p+q}((X, A) \times (Y, B)).$$

Let $a \in H_p(X, A)$, $b \in H_q(Y, B)$, $u \in H^p(X, A; G_1)$, and $v \in H^q(Y, B; G_2)$. Then

$$(-1)^{pq} \langle u \times v, \alpha(a \otimes b) \rangle = \langle u, a \rangle \otimes \langle v, b \rangle.$$

The proof of this relation is easy.

(b) Assume, as in (a) that $\{A \times Y, X \times B\}$ is an excisive couple in $X \times Y$. Let $u \in H^p(X, A; G_1)$, $v \in H^q(Y, B; G_2)$, and $w \in H_{p+q}(X \times Y, A \times Y \cup X \times B; G_3)$. Then

$$\langle u \times v, w \rangle = \langle u, v \setminus w \rangle.$$

(c) Assume that $\{A, B\}$ is an excisive couple in X . Let $u \in H^p(X, A; G_1)$, $v \in H^q(X, B; G_2)$, and $w \in H_{p+q}(X, A \cup B; G_3)$. Then

$$\langle u \cup v, w \rangle = \langle u, v \cap w \rangle.$$

A noteworthy special case of this relation occurs when $A = \emptyset$, $p = 0$, $G_1 = \mathbf{Z}$, and $u = 1 \in H^0(X; \mathbf{Z})$. Then $1 \cup v = v$, and it is easily verified that $\langle 1, v \cap w \rangle = \varepsilon_*(v \cap w)$. Thus, under these hypotheses, we obtain the relation

$$\langle v, w \rangle = \varepsilon_*(v \cap w)$$

which expresses the inner product in terms of the cap product and the augmentation.

The proof of relations (b) and (c) are easy. In the case where $G_1 = G_2 = G_3 = F$, where F is a field, and all the homology and cohomology groups involved are finite-dimensional vector spaces over F , relation (b) shows that cross products are determined by slant products, and vice versa. Similarly, relation (c) shows that under these hypotheses, cup products are determined by cap products, and vice versa (cf. Exercise XII.6.1).

§9. Cup and Cap Products in a Product Space

Let $u \in H^p(X, A)$, $v \in H^q(X, B)$, $w \in H^r(Y, C)$, and $x \in H^s(Y, D)$ (the coefficient groups are omitted from the notation). Then

$$(u \times w) \cup (v \times x) = (-1)^{qr} (u \cup v) \times (w \cup x) \quad (13.9.1)$$

provided we assume enough couples are excisive so that everything is well defined. In particular, this would be the case if A, B, C , and D were all empty.

Probably the easiest way to prove Equation (13.9.1) is to make use of the relation between cup and cross products explained in §3. If everything is expressed in terms of cup products, this relation becomes almost obvious. Therefore, the details are left to the reader.

To state an analogous relation for cap products, we must use the homomorphism

$$\alpha : H_p(X, A) \otimes H_q(Y, B) \rightarrow H_{p+q}(X \times Y, A \times Y \cup X \times B)$$

defined in §§XI.4 and XI.6. This can be extended in an obvious way to a homomorphism

$$\alpha: H_p(X, A; G_1) \otimes H_q(Y, B; G_2) \rightarrow H_{p+q}(X \times Y, A \times Y \cup X \times B, G_1 \otimes G_2)$$

with arbitrary coefficients G_1 and G_2 . Assume that $u \in H^p(X, A_1)$, $v \in H^q(Y, B_1)$, $a \in H^r(X, A_1 \cup A_2)$ and $b \in H^s(Y, B_1 \cup B_2)$. Then

$$(u \times v) \cap \alpha(a \otimes b) = (-1)^{qr} \alpha((u \cap a) \otimes (v \cap b)), \quad (13.9.2)$$

provided enough couples are assumed excisive. A detailed proof of this relation is written out in Dold [1, pp. 240–241].

This completes our survey of the main properties of the four products.

§10. Remarks on the Coefficients for the Various Products—The Cohomology Ring

In all four products, we started out with homology or cohomology classes u and v with coefficient groups G_1 and G_2 , respectively, and the product always had coefficient group $G_1 \otimes G_2$. Sometimes it is convenient to assume given a homomorphism $h: G_1 \otimes G_2 \rightarrow G$ and to systematically apply the coefficient homomorphism $h_\#$ to the resulting product. For example, if R is a ring and $h: R \otimes R \rightarrow R$ is the homomorphism induced by the multiplication, then we get a cup product which assigns to elements $u \in H^p(X; R)$ and $v \in H^q(X; R)$ an element $u \cup v \in H^{p+q}(X; R)$. With this multiplication, the direct sum

$$H^*(X; R) = \sum_n H^n(X; R)$$

becomes a kind of ring which is called a *graded ring*, because the underlying additive group is the direct sum of a sequence of subgroups, indexed by the integers. In fact, $H^*(X; R)$ is the prototype of a graded ring. If R has a unit $1 \in R$, then $H^*(X; R)$ has a unit $1_X \in H^0(X; R)$; it is represented by the cocycle

$$C_0(X) \xrightarrow{\varepsilon} \mathbf{Z} \xrightarrow{e} R,$$

where ε is the augmentation and e is the unique ring homomorphism defined by $e(1) = 1$. If the ring R is commutative, then $H^*(X; R)$ is commutative in the graded sense (sometimes called skew-commutative or anticommutative):

$$u \cup v = (-1)^{pq} v \cup u$$

for any $u \in H^p(X; R)$ and $v \in H^q(X; R)$. In this case, $H^*(X; R)$ is a *graded algebra* over the commutative ring R .

We mention two more examples like this, leaving the reader to fill in the details of the definitions, etc. For both examples, let R be a ring with unit, M a left R -module, and $h: R \otimes M \rightarrow M$ the homomorphism defining the module structure.

Examples

10.1. The cap product assigns to any elements $u \in H^p(X; R)$ and $v \in H_q(X; M)$ an element $u \cap v \in H_{q-p}(X; M)$. Using this cap product, the direct sum

$$H_*(X; M) = \sum_n H_n(X; M)$$

becomes a *graded left module* over the graded ring $H^*(X; R)$.

10.2. Let (X, A) be an arbitrary pair. The cup product assigns to elements $u \in H^p(X; R)$ and $v \in H^q(X, A; M)$ an element $u \cup v \in H^{p+q}(X, A; M)$. This makes

$$H^*(X, A; M) = \sum_n H^n(X, A; M)$$

into a *graded left module* over $H^*(X; R)$. Moreover, each of the homomorphisms of the exact sequence of the pair (X, A) ,

$$j^* : H^*(X, A; M) \rightarrow H^*(X; M),$$

$$i^* : H^*(X; M) \rightarrow H^*(A; M),$$

and

$$\delta^* : H^*(A; M) \rightarrow H^*(X, A; M)$$

are homomorphisms of graded left $H^*(X; R)$ -modules [the definition of the module structure on $H^*(X; M)$ and $H^*(A; M)$ is left to the reader]. In this example, the homomorphisms j^* and i^* have degree 0, whereas δ^* has degree +1.

§11. The Cohomology of Product Spaces (The Künneth Theorem for Cohomology)

By combining the Künneth theorem of §XI.6 with the universal coefficient theorem for cohomology of §XII.4, one can express the cohomology groups of a product space, $H^n(X \times Y; G)$ in terms of the homology groups of the factors, $H_p(X)$ and $H_q(Y)$ (in principle, at least). What we are now interested in is the expression of $H^n(X \times Y; G)$ in terms of the *cohomology* groups of the factors, $H^p(X)$ and $H^q(Y)$. The point is that we can use such an expression together with the relations given in §9 to obtain information about cup and cap products in $X \times Y$ terms of these products in the factors, X and Y .

The cross product defines a homomorphism

$$H^p(X; \mathbf{Z}) \otimes H^q(Y; \mathbf{Z}) \rightarrow H^{p+q}(X \times Y; \mathbf{Z}).$$

This definition can be extended in an obvious way to a homomorphism

$$\sum_{p+q=n} H^p(X; \mathbf{Z}) \otimes H^q(Y; \mathbf{Z}) \rightarrow H^n(X \times Y; \mathbf{Z}).$$

One would then hope to prove that this homomorphism is a monomorphism, and that the cokernel is isomorphic to something of the form

$$\sum_{p,q} \text{Tor}(H^p(X; \mathbf{Z}), H^q(Y; \mathbf{Z}))$$

just as in the case of homology. Unfortunately, simple examples show that this is too much to hope for: If X and Y are discrete spaces having infinitely many points, no such theorem holds. However, if X or Y is a *finite* discrete space, then there is no problem.

This is the key to the situation: one must impose some sort of finiteness condition on at least one of the factors.

Before we can state and prove such a theorem, we need some algebraic preliminaries. First of all, recall that if F is a free abelian group of *finite* rank then $\text{Hom}(F, \mathbf{Z})$ is also a free abelian group (of the same rank). It may be proved that if F is a free abelian of infinite rank, then $\text{Hom}(F, \mathbf{Z})$ is *not* free. However, we will have no need for this result. It follows that if $K = \{K_q, \partial_q\}$ is a chain complex such that K_q is free abelian of finite rank for each q , then $\text{Hom}(K, \mathbf{Z})$ is a cochain complex of free abelian groups.

Second, recall that we introduced earlier the natural homomorphism $\text{Hom}(A, A') \otimes \text{Hom}(B, B') \rightarrow \text{Hom}(A \otimes B, A' \otimes B')$ which assigns to homomorphisms $f: A \rightarrow A'$ and $g: B \rightarrow B'$ the tensor product of the two homomorphisms, $f \otimes g: A \otimes B \rightarrow A' \otimes B'$. In general, the abelian groups $\text{Hom}(A, A') \otimes \text{Hom}(B, B')$ and $\text{Hom}(A \otimes B, A' \otimes B')$ are *not* isomorphic. However, in the special case where A is free abelian of finite rank and $A' = \mathbf{Z}$, it is readily verified that the natural homomorphism is an isomorphism of $\text{Hom}(A, \mathbf{Z}) \otimes \text{Hom}(B, B')$ onto $\text{Hom}(A \otimes B, B')$. We can now extend this result to chain complexes. Suppose that $K = \{K_q, \partial_q\}$ is a positive chain complex such that each K_q is free abelian of finite rank, that $C = \{C_q, \partial_q\}$ is another positive chain complex, and G is an abelian group. Then the natural chain map

$$\text{Hom}(K, \mathbf{Z}) \otimes \text{Hom}(C, G) \rightarrow \text{Hom}(K \otimes C, G)$$

is an isomorphism of chain complexes.

Finally, we need the following lemma of a rather technical nature:

Lemma 11.1. *Let (X, A) be a pair such that $H_q(X, A)$ is finitely generated for all q . Then there exists a chain complex $K = \{K_q, \partial_q\}$ such that each K_q is a free abelian group of finite rank, and a chain homotopy equivalence $f: K \rightarrow C(X, A)$.*

PROOF. For each q , choose an epimorphism e_q of a finitely generated free abelian group F_q onto $H_q(X, A)$; denote the kernel by R_{q+1} , and let $d_{q+1}: R_{q+1} \rightarrow F_q$ denote the inclusion homomorphism. Then

$$0 \longleftarrow H_q(X, A) \xleftarrow{e_q} F_q \xleftarrow{d_{q+1}} R_{q+1} \longleftarrow 0$$

is a short exact sequence, and both F_q and R_{q+1} are free abelian of finite rank.

Define $K_q = F_q \oplus R_q$ for all q , and $\partial_q : K_q \rightarrow K_{q-1}$ by

$$\partial_q|_{F_q} = 0,$$

$$\partial_q|_{R_q} = d_q.$$

Then $K = \{K_q, \partial_q\}$ is a chain complex such that each K_q is free abelian of finite rank. It is an easy exercise to prove that there exist homomorphisms

$$\varphi_q : F_q \rightarrow Z_q(X, A),$$

$$\psi_{q+1} : R_{q+1} \rightarrow B_q(X, A)$$

for all q such that the following diagram is commutative:

$$\begin{array}{ccccccccc} 0 & \longleftarrow & H_q(X, A) & \xleftarrow{e_q} & F_q & \xleftarrow{d_{q+1}} & R_{q+1} & \longleftarrow & 0 \\ & & \parallel & & \downarrow \varphi_q & & \downarrow \psi_{q+1} & & \\ 0 & \longleftarrow & H_q(X, A) & \longleftarrow & Z_q(X, A) & \longleftarrow & B_q(X, A) & \longleftarrow & 0 \end{array}$$

Next, we may choose a homomorphism $\theta_{q+1} : R_{q+1} \rightarrow C_{q+1}(X, A)$ such that the following diagram is commutative:

$$\begin{array}{ccc} & & C_{q+1}(X, A) \\ & \nearrow \theta_{q+1} & \downarrow \partial_q \\ R_{q+1} & & B_q(X, A) \\ & \searrow \psi_{q+1} & \downarrow \\ & & 0 \end{array}$$

Now define $f_q : K_q \rightarrow C_q(X, A)$ by

$$f_q|_{F_q} = \varphi_q,$$

$$f_q|_{R_q} = \theta_q.$$

It is readily checked that $f = \{f_q\}$ is a chain map, and that the induced homomorphism

$$f_* : H_q(K) \rightarrow H_q(X, A)$$

is an isomorphism for all q . Therefore, f is a chain homotopy equivalence, by Theorem X.2.8. Q.E.D.

Now that we have these technical details behind us, we can state the desired theorem:

Theorem 11.2. *Let (X, A) and (Y, B) be pairs such that the following two conditions hold: $H_q(X, A)$ is finitely generated for all q , and $\{X \times B, A \times Y\}$ is an excisive couple in $X \times Y$. Then the cross product defines a homomorphism*

$\alpha: \sum_{p+q=n} H^p(X, A; \mathbf{Z}) \otimes H^q(Y, B; G) \rightarrow H^n(X \times Y; A \times Y \cup X \times B; G)$ which is a monomorphism onto a direct summand and the cokernel is naturally isomorphic to $\sum_{p+q=n+1} \text{Tor}(H^p(X, A; \mathbf{Z}), H^q(Y, B; G))$.

We will indicate the main steps in the proof, leaving the verification of details to the reader.

By Lemma 11.1, there exists a chain complex K of finitely generated free abelian groups and a chain homotopy equivalence $f: K \rightarrow C(X, A)$. It follows that $\text{Hom}(K, \mathbf{Z})$ is a cochain complex of free abelian groups, and $\text{Hom}(f, 1): \text{Hom}(C(X, A), \mathbf{Z}) \rightarrow \text{Hom}(K, \mathbf{Z})$ is also a chain homotopy equivalence. Now consider the following commutative diagram of cochain complexes and cochain maps:

$$\begin{array}{ccc}
 \text{Hom}(K \otimes C(Y, B), G) & \xleftarrow{\text{Hom}(f \otimes 1, 1)} & \text{Hom}(C(X, A) \otimes C(Y, B), G) \\
 \uparrow a & & \uparrow \\
 \text{Hom}(K, \mathbf{Z}) \otimes \text{Hom}(C(Y, B), G) & \xleftarrow{\text{Hom}(f, 1) \otimes 1} & \text{Hom}(C(X, A), \mathbf{Z}) \otimes \text{Hom}(C(Y, B), G)
 \end{array}$$

In this diagram, the symbol 1 refers to an appropriate identity map. By the discussion preceding Lemma 11.1, the arrow labeled a denotes an isomorphism. Since f is a chain homotopy equivalence, it follows that the horizontal arrows denote cochain homotopy equivalences. Hence on passage to cohomology, all four arrows in this diagram would induce isomorphisms. To complete the proof, one applies the Künneth theorem to the tensor product $\text{Hom}(K, \mathbf{Z}) \otimes \text{Hom}(C(Y, B), G)$. This is legitimate, since $\text{Hom}(K, \mathbf{Z})$ is a cochain complex of free abelian groups. The remaining details may be left to the reader. Q.E.D.

Corollary 11.3. *Let X and Y be topological spaces such that $H_q(X)$ is finitely generated for all q and such that at least one of the two spaces has all cohomology groups torsion-free. Then*

$$\alpha: \sum_{p+q=n} H^p(X; \mathbf{Z}) \otimes H^q(Y; \mathbf{Z}) \rightarrow H^n(X \times Y; \mathbf{Z})$$

is an isomorphism for all n . In this case the cohomology ring $H^(X \times Y; \mathbf{Z})$ is completely determined by $H^*(X; \mathbf{Z})$ and $H^*(Y; \mathbf{Z})$.*

The last sentence of this corollary follows from the relations for cup products in a product space given in §9. It also inspires the following definition.

Definition 11.4. Let $A^* = \sum_i A^i$ and $B^* = \sum_j B^j$ be graded rings. The *tensor product* $A^* \otimes B^*$ is the graded ring defined as follows:

$$(A^* \otimes B^*)^n = \sum_{i+j=n} A^i \otimes B^j \quad (\text{direct sum}).$$

The multiplication is defined as follows:

$$(u_1 \otimes v_1) \cdot (u_2 \otimes v_2) = (-1)^{p_2 q_1} (u_1 u_2) \otimes (v_1 v_2),$$

where $u_i \in A^{p_i}$ and $v_j \in B^{q_j}$ for $i, j = 1, 2$. With this structure $A^* \otimes B^*$ is also a graded ring.

Using this definition, the corollary above can be restated as follows: *Let X and Y be topological spaces such that $H_q(X)$ is finitely generated for all q , and at least one of the two spaces has all cohomology groups torsion-free. Then the cohomology ring $H^*(X \times Y; \mathbf{Z})$ is naturally isomorphic to the tensor product of the cohomology rings of the factors:*

$$\alpha: H^*(X; \mathbf{Z}) \otimes H^*(Y; \mathbf{Z}) \approx H^*(X \times Y; \mathbf{Z})$$

Examples

11.1. The cohomology ring of an n -sphere, $H^*(S^n; \mathbf{Z})$ is easily determined. We know that $H^0(S^n; \mathbf{Z})$ is an infinite cyclic group generated by the unit, $1 \in H^0(S^n; \mathbf{Z})$, and $H^n(S^n; \mathbf{Z})$ is also infinite cyclic with generator u ; all other cohomology groups are 0. The cup products are completely determined by the equations

$$u \cup 1 = 1 \cup u = u.$$

We can now use the above rules to determine the cohomology ring $H^*(S^m \times S^n; \mathbf{Z})$. Let $u \in H^m(S^m; \mathbf{Z})$ and $v \in H^n(S^n; \mathbf{Z})$ denote generators of these infinite cyclic groups. Then $H^*(S^m \times S^n; \mathbf{Z})$ is the direct sum of four infinite cyclic groups, with generators 1×1 (the unit), $u \times 1$, $1 \times v$, and $u \times v$. There is one nontrivial product:

$$(u \times 1) \cup (1 \times v) = u \times v.$$

EXERCISES

11.1. Let A be a retract of X with retraction $r: X \rightarrow A$ and inclusion map $i: A \rightarrow X$. Consider the induced homomorphisms

$$r^*: H^*(A; \mathbf{Z}) \rightarrow H^*(X; \mathbf{Z}),$$

$$i^*: H^*(X; \mathbf{Z}) \rightarrow H^*(A; \mathbf{Z}).$$

Prove that kernel i^* is an ideal in the graded ring $H^*(X; \mathbf{Z})$, and image r^* is a subring.

11.2. Let X and Y be spaces with chosen base points, $x_0 \in X$ and $y_0 \in Y$. Define

$$X \vee Y = (X \times \{y_0\}) \cup (\{x_0\} \times Y).$$

It is sometimes called the 1-point union of X and Y . Assuming that X and Y are arcwise connected, express the structure of the cohomology ring $H^*(X \vee Y; \mathbf{Z})$ in terms of $H^*(X; \mathbf{Z})$ and $H^*(Y; \mathbf{Z})$. (Assume also that x_0 and y_0 have "nice" neighborhoods in X and Y respectively, as described in Problem VIII.5.2.)

11.3. Let m and n be positive integers, $X = S^m \times S^n$, and $Y = S^m \vee S^n \vee S^{m+n}$. Prove that $H_q(X; G) \approx H_q(Y; G)$ and $H^q(X; G) \approx H^q(Y; G)$ for any abelian group G and integer q ; then prove that X and Y are *not* of the same homotopy type.

We conclude this lengthy chapter with an analogue of Corollary 11.3 for the case where we use cohomology with *coefficients in a commutative field* F . The result is easy to state, and of rather wide generality.

Theorem 11.5. *Let (X, A) and (Y, B) be pairs such that $\{X \times B, A \times Y\}$ is an excisive couple, and $H_q(X, A; F)$ is a finite-dimensional vector space over F for all q . Then the \times -product defines a natural isomorphism*

$$\alpha: \sum_{p+q=n} H^p(X, A; F) \otimes_F H^q(Y, B; F) \rightarrow H^n(X \times Y, A \times Y \cup X \times B; F).$$

Corollary 11.6. *Let X be a space such that $H_q(X; F)$ has finite rank over F for all q . Then for any space Y , the cohomology algebra $H^*(X \times Y; F)$ is naturally isomorphic to the tensor product:*

$$\alpha: H^*(X; F) \otimes_F H^*(Y; F) \approx H^*(X \times Y; F).$$

The proof of this theorem and corollary is actually somewhat simpler than the proof of Theorem 11.2 and Corollary 11.3 because one has to deal with vector spaces over F rather than abelian groups. It is also necessary to use relations such as the following:

$$C(X) \otimes C(Y) \otimes F \approx C(X, F) \otimes_F C(Y, F),$$

$$\text{Hom}(C(X), F) \approx \text{Hom}_F(C(X, F), F).$$

Once again, the details are left to the reader.

NOTES

The cup and cap products were introduced by Alexander, Čech, Kolmogoroff, and Whitney when they introduced cohomology groups in the years 1935–38 (see the Notes at the end of Chapter XII). The close relation between the cup products and the cross products was first described and exploited by Lefschetz in his 1942 A. M. S. Colloquium Volume (also referred to in the Notes to Chapter XII).

There was one predecessor of cup products, which existed before the development of cohomology theory. In the middle 1920s, J. W. Alexander and S. Lefschetz developed an “intersection theory” of homology classes in a compact oriented manifold. For more information on this, see the notes at the end of Chapter XIV.

References

1. A. Dold, *Lectures on Algebraic Topology*, Springer-Verlag, New York, 1972.
2. S. Eilenberg and N. Steenrod, *Foundations of Algebraic Topology*, Princeton University Press, Princeton, N.J., 1952.

CHAPTER XIV

Duality Theorems for the Homology of Manifolds

§1. Introduction

An n -dimensional manifold is a Hausdorff space such that every point has an open neighborhood which is homeomorphic to Euclidean n -space, \mathbf{R}^n (see Chapter I). One of the main goals of this chapter will be to prove one of the oldest results of algebraic topology, the famous Poincaré duality theorem for compact, orientable manifolds. It is easy to state the Poincaré duality theorem but the proof is lengthy.

If a compact connected n -dimensional manifold M can be subdivided into cells so as to be a regular cell complex, then it is a pseudomanifold, and the results of §IX.8 are applicable. Thus, if it is orientable, $H_n(M, \mathbf{Z})$ will be an infinite cyclic group. One of our first goals will be to prove that this result is still true even if the manifold is not a regular cell complex. To “orient” such a manifold means to choose a generator μ of the group $H_n(M, \mathbf{Z})$. The Poincaré duality theorem then asserts that *the homomorphism of $H^q(M^n, G)$ into $H_{n-q}(M^n, G)$, defined by $x \rightarrow x \cap \mu$ for any $x \in H^q(M^n, G)$, is an isomorphism for all integers q and all coefficient groups G !* This is a rather severe restriction on the homology and cohomology groups of a compact, orientable manifold. By using the relation $(x \cup y) \cap \mu = x \cap (y \cap \mu)$, we will be able to show that the Poincaré duality theorem has strong implications for cup products in a manifold.

We will also prove a duality theorem relating the homology and cohomology groups of a manifold with boundary. Finally, we will discuss the famous Alexander duality theorem. This relates the cohomology groups of a closed subset X of Euclidean n -space, \mathbf{R}^n , and the homology groups of the complementary set $\mathbf{R}^n - X$. It is a far-reaching generalization of the results proved in VIII.6 (i.e., the Jordan–Brouwer separation theorem, etc).

The method of proof we use for the Poincaré duality theorem is that described by J. Milnor in some mimeographed lecture notes in 1964; see also the appendix to [8]. The basic idea of Milnor's proof is very natural and may be explained as follows. It follows from the definition that any n -manifold is a union of certain open subsets, each of which is homeomorphic to \mathbf{R}^n . Thus, it seems natural to try to prove the theorem first for \mathbf{R}^n , and then to use Mayer–Vietoris sequences to extend to the case of a finite union of open subsets, each of which is homeomorphic to \mathbf{R}^n . Finally we can extend to the case of an infinite union of such open sets by a direct limit argument. The only trouble with this idea is that the Poincaré duality theorem as formulated above applies *only* to compact manifolds. Thus, it will be necessary to state and prove a more general version of the Poincaré duality theorem which is also applicable to noncompact manifolds. The reader must not let the technical complications involved in stating and proving this more general version obscure the basic ideas involved.

§2. Orientability and the Existence of Orientations for Manifolds

Let M be an arbitrary n -dimensional manifold; we emphasize that M need not be compact or connected; in fact we do not even need to assume that M is paracompact! For any point $x \in M$, consider the local homology groups $H_i(M, M - \{x\})$ (cf. §VIII.2). Using the fact that x has a neighborhood homeomorphic to \mathbf{R}^n and the excision property, we see that

$$H_i(M, M - \{x\}) \approx H_i(\mathbf{R}^n, \mathbf{R}^n - \{x\}).$$

Hence, if we use integer coefficients, $H_i(M, M - \{x\})$ is infinite cyclic for $i = n$, and zero for $i \neq n$. A choice of a generator for the infinite cyclic group $H_n(M, M - \{x\}; \mathbf{Z})$ will be referred to as a *local orientation* of M at x .

Definition 2.1. An *orientation* of an n -dimensional manifold M is a function μ which assigns to each point $x \in M$ a local orientation $\mu_x \in H_n(M, M - \{x\}; \mathbf{Z})$ subject to the following continuity condition: Given any point $x \in M$, there exists a neighborhood N of x and an element $\mu_N \in H_n(M, M - N)$ such that $i_*(\mu_N) = \mu_y$ for any $y \in N$, where $i_* : H_n(M, M - N) \rightarrow H_n(M, M - \{y\})$ denotes the homomorphism induced by inclusion.

In order to better understand this continuity condition, recall that any point $x \in M$ has an open neighborhood U which is homeomorphic to \mathbf{R}^n . By the excision property, for any $y \in U$,

$$H_n(U, U - \{y\}) \approx H_n(M, M - \{y\}).$$

However, if x and y are any two points of \mathbf{R}^n , there is a canonical isomorphism

$H_n(\mathbf{R}^n, \mathbf{R}^n - \{x\}) \approx H_n(\mathbf{R}^n, \mathbf{R}^n - \{y\})$ defined by choosing a closed ball $E^n \subset \mathbf{R}^n$ large enough so that x and y are both in the interior of E^n , and noting that in the following diagram,

$$\begin{array}{ccc} H_n(\mathbf{R}^n, \mathbf{R}^n - \{x\}) & \xleftarrow{i_*} & H_n(\mathbf{R}^n, \mathbf{R}^n - E^n) \\ & & \downarrow j_* \\ & & H_n(\mathbf{R}^n, \mathbf{R}^n - \{y\}) \end{array}$$

both i_* and j_* are isomorphisms. Moreover, the isomorphism between $H_n(\mathbf{R}^n, \mathbf{R}^n - \{x\})$ and $H_n(\mathbf{R}^n, \mathbf{R}^n - \{y\})$ that we thus obtain is independent of the choice of the ball E^n .

Terminology. The manifold M is said to be *orientable* if it admits at least one orientation; otherwise, it is called *nonorientable*. A pair consisting of a manifold M and an orientation is called an *oriented manifold*.

The reader should convince himself that for 2-dimensional manifolds, these definitions agree with those of Chapter I.

Examples

2.1. (a) Euclidean n -space, \mathbf{R}^n , is orientable (use the fact mentioned above that there exists a canonical isomorphism $H_n(\mathbf{R}^n, \mathbf{R}^n - \{x\}) \approx H_n(\mathbf{R}^n, \mathbf{R}^n - \{y\})$ for any two points $x, y \in \mathbf{R}^n$). (b) Similarly, the n -sphere, S^n , is orientable according to our definition. (c) If M is an n -manifold, μ is an orientation for M , and N is an open subset of M , then μ restricted to N is an orientation of the n -manifold N . In particular, if M is oriented and disconnected, then each component is oriented. If any component is nonorientable, then so is M . (d) Let M be an m -dimensional manifold with orientation μ and N an n -dimensional manifold with orientation ν . Let $\mu \times \nu$ denote the function which assigns to each point $(x, y) \in M \times N$ the homology class

$$\alpha(\mu_x \otimes \nu_y) \in H_{m+n}(M \times N, M \times N - \{(x, y)\}),$$

where α is the homomorphism which occurs in Theorem XI.6.1. It is readily seen that $\alpha(\mu_x \otimes \nu_y)$ is a generator of the homology group in question. It is also easy to verify that the required continuity condition holds, and thus $\mu \times \nu$ is an orientation for $M \times N$. Thus, the product of two orientable manifolds is orientable.

In dealing with questions such as these, we will need to frequently consider for any subset A of the manifold M , the homology groups $H_i(M, M - A)$. If $B \subset A$, it will be convenient to denote the corresponding homomorphism $H_i(M, M - A) \rightarrow H_i(M, M - B)$ by the symbol ρ_B ; for any homology class $u \in H_i(M, M - A)$, $\rho_B(u)$ can be thought of as the "restriction" of u to a homology group associated with B .

Let M be an n -dimensional manifold with orientation μ ; it would be advantageous if there were a global homology class $\mu_M \in H_n(M, \mathbf{Z})$ such that for any $x \in M$,

$$\mu_x = \rho_x(\mu_M).$$

Unfortunately, this cannot be true if M is noncompact, as the reader can easily verify by using Proposition VIII.6.1. The closest possible approximation to such a result is the following theorem. It will play a crucial role in the statement and proof of the Poincaré duality theorem:

Theorem 2.2. *Let M be an n -manifold with orientation μ . Then for each compact set $K \subset M$ there exists a unique homology class $\mu_K \in H_n(M, M - K)$ such that*

$$\rho_x(\mu_K) = \mu_x$$

for each $x \in K$.

Note that if M is a compact manifold, this theorem assures us of the existence of a unique global homology class $\mu_M \in H_n(M, \mathbf{Z})$ such that for any point $x \in M$,

$$\mu_x = \rho_x(\mu_M).$$

PROOF. The uniqueness of μ_K is a direct consequence of a more general lemma below (Lemma 2.3). Therefore, we will concentrate on the existence proof. Obviously, if the compact set K is contained in a sufficiently small neighborhood of some point, the continuity condition in the definition of μ assures us of the existence of μ_K . Next, suppose that $K = K_1 \cup K_2$, where K_1 and K_2 are compact subsets of M , and both μ_{K_1} and μ_{K_2} are assumed to exist. Then $\{M - K_1, M - K_2\}$ is an excisive couple, and hence we have a relative Mayer–Vietoris sequence (cf. §XIII.6):

$$\begin{aligned} H_{n+1}(M, M - K_1 \cap K_2) &\xrightarrow{\Delta} H_n(M, M - K) \\ &\xrightarrow{\varphi} H_n(M, M - K_1) \oplus H_n(M, M - K_2) \\ &\xrightarrow{\psi} H_n(M, M - K_1 \cap K_2). \end{aligned}$$

Recall that the homomorphisms φ and ψ are defined by

$$\varphi(u) = (\rho_{K_1}(u), \rho_{K_2}(u)),$$

$$\psi(v_1, v_2) = \rho_{K_1 \cap K_2}(v_1) - \rho_{K_1 \cap K_2}(v_2)$$

for any $u \in H_n(M, M - K)$, $v_1 \in H_n(M, M - K_1)$, and $v_2 \in H_n(M, M - K_2)$. By the uniqueness of $\mu_{K_1 \cap K_2}$, we see that

$$\begin{aligned} \rho_{K_1 \cap K_2}(\mu_{K_1}) &= \rho_{K_1 \cap K_2}(\mu_{K_2}) \\ &= \mu_{K_1 \cap K_2}, \end{aligned}$$

and hence

$$\psi(\mu_{K_1}, \mu_{K_2}) = 0.$$

It follows from Lemma 2.3 below that $H_{n+1}(M, M - (K_1 \cap K_2)) = 0$; hence by exactness there is a unique homology class $\mu_K \in H_n(M, M - K)$ such that

$$\varphi(\mu_K) = (\mu_{K_1}, \mu_{K_2}).$$

It is readily verified that this homology class μ_K satisfies the desired condition $\rho_x(\mu_K) = \mu_x$ for any $x \in K$.

Next, assume that $K = K_1 \cup K_2 \cup \cdots \cup K_r$, where each K_i is a compact subset of M , and μ_{K_i} exists. By an obvious induction on r , using what we have just proved, we can conclude that μ_K exists. But any compact subset K of M can obviously be expressed as a finite union of subsets K_i , each of which is sufficiently small so that the corresponding homology class μ_{K_i} exists. Hence μ_K exists, as was to be proved. Q.E.D.

It remains to state and prove Lemma 2.3.

Lemma 2.3. *Let M be an n -dimensional manifold and G an abelian group.*

(a) *For any compact set $K \subset M$ and all $i > n$,*

$$H_i(M, M - K; G) = 0$$

(b) *If $u \in H_n(M, M - K; G)$ and $\rho_x(u) = 0$ for all $x \in K$, then $u = 0$.*

PROOF. The method of proof is to start with the case $M = \mathbf{R}^n$ and then to progress to successively more complicated cases, ending with the general case.

Case 1: $M = \mathbf{R}^n$ and K is a compact, convex subset of \mathbf{R}^n . To prove this case, choose a large ball $E^n \subset \mathbf{R}^n$ such that K is contained in the interior of E^n . For any $x \in K$, consider the following commutative diagram:

$$\begin{array}{ccc} H_i(M, M - K) & \xrightarrow{\rho_x} & H_i(M, M - \{x\}) \\ & \swarrow 1 & \searrow 2 \\ & H_i(E^n, S^{n-1}) & \end{array}$$

Then it is readily proved that arrows 1 and 2 are isomorphisms. Hence, ρ_x is an isomorphism for all i which suffices to prove that lemma in this case.

Case 2: $K = K_1 \cup K_2$, where K , K_1 , and K_2 are compact subsets of M and it is assumed that the lemma is true for K_1 , K_2 , and $K_1 \cap K_2$. In order to prove this case, we will again use the relative Mayer–Vietoris sequence of the triad $(M; M - K_1, M - K_2)$. The proof of this case is based on the following portion of this Mayer–Vietoris sequence:

$$\begin{aligned} H_{i+1}(M, M - K_1 \cap K_2) &\xrightarrow{\Delta} H_i(M, M - K) \\ &\xrightarrow{\varphi} H_i(M, M - K_1) \oplus H_i(M, M - K_2). \end{aligned}$$

The proof of parts (a) and (b) of the lemma for this case is quite easy and may be left to the reader.

Case 3: $M = \mathbf{R}^n$ and $K = K_1 \cup K_2 \cup \cdots \cup K_r$, where each K_i is compact and convex. This case is proved by induction on r , using cases 1 and 2 (the fact that the intersection of convex sets is convex is used).

Case 4: $M = \mathbf{R}^n$, and K is an arbitrary compact subset. We assert that for any $u \in H_i(\mathbf{R}^n, \mathbf{R}^n - K)$, there exists an open set N containing K and an elements $u' \in H_i(\mathbf{R}^n, \mathbf{R}^n - N)$ such that $k_*(u') = u$, where

$$k : (\mathbf{R}^n, \mathbf{R}^n - N) \rightarrow (\mathbf{R}^n, \mathbf{R}^n - K)$$

is the inclusion map. To prove this assertion, recall that there exists a compact pair $(X, A) \subset (\mathbf{R}^n, \mathbf{R}^n - K)$, and a homology class $v \in H_i(X, A)$ such that the inclusion homomorphism $H_i(X, A) \rightarrow H_i(\mathbf{R}^n, \mathbf{R}^n - K)$ maps v onto u (see Proposition VIII.6.1). Now we may choose N to be any open neighborhood of K which is disjoint from A , and the assertion will certainly be true.

Given the open neighborhood N of K , we may find a finite collection $\{B_1, B_2, \dots, B_r\}$ of closed balls such that $B_j \subset N$ for $1 \leq j \leq r$, and the union of the B_j 's covers K . We may also assume that $K \cap B_j \neq \emptyset$ for $1 \leq j \leq r$. Now consider the following commutative diagram:

$$\begin{array}{ccc} H_i(\mathbf{R}^n, \mathbf{R}^n - N) & \xrightarrow{l_*} & H_i\left(\mathbf{R}^n, \mathbf{R}^n - \bigcup_j B_j\right) \\ & \searrow k_* & \downarrow m_* \\ & & H_i(\mathbf{R}^n, \mathbf{R}^n - K) \end{array}$$

We will use this diagram to prove the lemma for this case. The proof of part (a) for this case is very easy: If $i > n$, then $H_i(\mathbf{R}^n, \mathbf{R}^n - \bigcup_j B_j) = 0$ by case 3, and hence the given element $k_*(u') = u \in H_i(\mathbf{R}^n, \mathbf{R}^n - K)$ must be zero also. The proof of part (b) is only slightly more difficult. Assume $u \in H_n(\mathbf{R}^n, \mathbf{R}^n - K)$, $\rho_x(u) = 0$ for all $x \in K$, and that N and $u' \in H_n(\mathbf{R}^n, \mathbf{R}^n - N)$ have been chosen so that $u = k_*(u')$. Let $u'' = l_*(u') \in H_n(\mathbf{R}^n, \mathbf{R}^n - \bigcup_j B_j)$ in the above diagram. We assert that $\rho_y(u'') = 0$ for each $y \in B_1 \cup B_2 \cup \cdots \cup B_r$. To see this, assume that $y \in B_i$; choose a point $x \in B_i \cap K$. Consider the following commutative diagram:

$$\begin{array}{ccc} H_n\left(\mathbf{R}^n, \mathbf{R}^n - \bigcup_j B_j\right) & \longrightarrow & H_n(\mathbf{R}^n, \mathbf{R}^n - B_i) \\ \downarrow m_* & \swarrow \rho_y & \downarrow 1 \\ & H_n(\mathbf{R}^n, \mathbf{R}^n - \{y\}) & \\ & \downarrow 2 & \\ & & H_n(\mathbf{R}^n, \mathbf{R}^n - \{x\}) \\ & \nearrow p_x & \\ & H_n(\mathbf{R}^n, \mathbf{R}^n - K) & \end{array}$$

All homomorphisms in this diagram are induced by inclusion maps, and the homomorphisms denoted by arrows 1 and 2 are isomorphisms, (by case 1).

Since $m_*(u'') = u$, and $\rho_x(u) = 0$, it readily follows that $\rho_y(u'') = 0$ as desired. Therefore, we can conclude by case 3 that $u'' = 0$, and hence $u = m_*(u'')$ is also zero.

Case 5: M is arbitrary, but the compact set K is assumed to be “small” enough so that there exists an open set U which is homeomorphic to \mathbf{R}^n and $U \subset K$. In this case $H_i(M, M - K) \approx H_i(U, U - K)$ by the excision property; hence, we can apply case 4 to reach the desired conclusion.

Case 6: The general case. In this case, K is a finite union of compact subsets,

$$K = K_1 \cup K_2 \cup \cdots \cup K_r,$$

where each K_i is small enough so that case 5 applies. Hence, we can make an induction on r , using case 2, to compute the proof of the lemma. Q.E.D.

In order to study the homology of arbitrary manifolds (i.e., orientable or nonorientable) it is desirable to go through similar considerations with \mathbf{Z}_2 coefficients. Let M be an arbitrary n -dimensional manifold, and $x \in M$. The local homology group $H_n(M, M - \{x\}; \mathbf{Z}_2)$ is cyclic of order 2; hence, it has a unique generator $\mu_x \in H_n(M, M - \{x\}; \mathbf{Z}_2)$ (no choice is involved). It is readily seen that the function μ which assigns to each $x \in M$ the element μ_x satisfies the continuity condition occurring in the definition of an orientation: Each point $x \in M$ has a neighborhood N for which there exists an element $\mu_N \in H_n(M, M - N; \mathbf{Z}_2)$ such that $\rho_y(\mu_N) = \mu_y$ for all $y \in N$. It is convenient to refer to μ as the “mod 2 orientation of M .”

Theorem 2.4. *Let M be an arbitrary n -dimensional manifold (i.e., M need not be orientable). Then for each compact set $K \subset M$ there exists a unique homology class $\mu_K \in H_n(M, M - K; \mathbf{Z}_2)$ such that*

$$\rho_x(\mu_K) = \mu_x$$

for any $x \in K$, where μ_x denotes the unique nonzero element of the local homology group $H_n(M, M - \{x\}; \mathbf{Z}_2)$.

The proof may be patterned on that of Theorem 2.2; the details are left to the reader.

EXERCISES

In the first three exercises, it is assumed that the reader is familiar with the theory of covering spaces; see Chapter V.

- 2.1. Let (\tilde{X}, p) be a covering space of X , where X and \tilde{X} are both locally arcwise connected Hausdorff spaces. Prove that X is an n -dimensional manifold if and only if \tilde{X} is an n -dimensional manifold.
- 2.2. Let (\tilde{M}, p) be a covering space of M , where \tilde{M} and M are both connected n -manifolds. Assume that M is orientable. Prove that \tilde{M} is orientable, and that

every covering transformation (i.e., automorphism) of (\tilde{M}, p) is orientation preserving (the definition of *orientation preserving* is the obvious one).

2.3. Let (\tilde{M}, p) be a regular covering space of M . Assume \tilde{M} is a connected, orientable n -manifold, and that every covering transformation of (\tilde{M}, p) is orientation preserving. Prove that M is orientable.

2.4. (A continuity lemma). Let K be a compact subset of the n -dimensional manifold M , $u \in H_n(M, M - K; G)$, and $x \in K$. Prove that there exists an open neighborhood N of x and a unique element $u_N \in H_n(M, M - N; G)$ such that the following two properties are true:

- (a) For any $y \in N$, $\rho_y : H_n(M, M - N; G) \rightarrow H_n(M, M - \{y\}; G)$ is an isomorphism.
- (b) For any $y \in N \cap K$, $\rho_y(u) = \rho_y(u_N)$.

[HINT: To ensure that (a) will be true, choose N to be an open n -dimensional ball such that $M - N$ is a deformation retract of $M - \{y\}$. To prove the existence of u_N , use Proposition VIII.6.1.)

2.5. Prove the following corollaries of the preceding exercise:

- (a) Let K be a compact subset of M and $u \in H_n(M; M - K; G)$. Then the following two sets

$$\{x \in K \mid \rho_x(u) = 0\},$$

$$\{x \in K \mid \rho_x(u) \neq 0\}$$

are both open subsets of K . Hence, if K is connected, one of them must be empty.

- (b) Let K be a compact, *connected* subset of M . Then $H_n(M, M - K; \mathbf{Z})$ is either infinite cyclic or zero.

[HINT: Use part (a) and Lemma 2.3). If $H_n(M, M - K; \mathbf{Z})$ is infinite cyclic, then $\rho_y : H_n(M, M - K) \rightarrow H_n(M, M - \{y\})$ is a monomorphism for any $y \in K$.

- (c) Let K be a compact, *connected* subset of M , $u \in H_n(M, M - K; \mathbf{Z})$ and let $x \in K$ be such that $\rho_x(u)$ is k times a generator of $H_n(M, M - \{x\})$. Prove that for any $y \in K$, $\rho_y(u)$ is also k times a generator of $H_n(M, M - \{y\})$.

2.6. Assume that M is connected, and that for each compact $K \subset M$, $H_n(M, M - K; \mathbf{Z}) \neq \{0\}$. Prove that M is orientable. [HINT: use the fact that any two points of M are contained in a compact connected subset of M , e.g., a path joining the two points.)

2.7. Let M be a compact, *connected*, nonorientable manifold. Prove that $H_n(M; \mathbf{Z}) = 0$.

2.8. For any abelian group G , let ${}_2G = \{g \in G \mid 2g = 0\}$. Recall that there is a natural isomorphism $\alpha : H_n(M, M - \{x\}; \mathbf{Z}) \otimes G \rightarrow H_n(M, M - \{x\}; G)$ for any point x of the n -manifold M (see §X.6). Show that if $g \in {}_2G$, the element $g_x = \alpha(\mu_x \otimes g) \in H_n(M, M - \{x\}; G)$ is independent of the choice of the local orientation $\mu_x \in H_n(M, M - \{x\}; \mathbf{Z})$. Then prove that for each compact set $K \subset M$ and $g \in {}_2G$, there exists a unique homology class $g_K \in H_n(M, M - K; G)$ such that $\rho_x(g_K) = g_x$ for any $x \in K$.

- 2.9.** Let M be a connected n -dimensional manifold. Assume that for each compact set $K \subset M$ there is chosen an element $h_K \in H_n(M, M - K; G)$ such that $\rho_x(h_K) = h_x$ for any $x \in K$, and that $2h_x \neq 0$ for all $x \in M$. Prove that the manifold M is orientable. [HINT: Show that there exists a fixed element $h \in G$ and unique local orientations μ_x for all $x \in M$ such that $h_x = \alpha(\mu_x \otimes h)$. Note that h cannot be an element of ${}_2G$.]
- 2.10.** Let M be a compact, connected, nonorientable, n -dimensional manifold and G an abelian group. Prove that $H_n(M; G)$ is isomorphic to ${}_2G$. (Use the results of the preceding exercises).
- 2.11.** Let M be a compact, connected, nonorientable n -dimensional manifold. Prove that the torsion subgroup of $H_{n-1}(M; \mathbf{Z})$ is cyclic of order 2. (Use the results of Exercises 2.7 and 2.10 and the universal coefficient theorem. You may make use of the fact that all the integral homology groups of M are finitely generated; see Lemma 5.2 of this chapter. The reader should compare the statements of this exercise and Exercise 2.7 with the theorems about pseudomanifolds in §IX.8.)

§3. Cohomology with Compact Supports

In order to state and prove the Poincaré duality theorem for noncompact manifolds, it is necessary to use a new kind of cohomology theory, called *cohomology with compact supports*. On compact spaces, this new cohomology theory reduces to the usual kind of cohomology.

Recall that $C^*(X, A; G)$ is a subcomplex of $C^*(X; G)$; it is (by definition) the kernel of the cochain map

$$i^\# : C^*(X; G) \rightarrow C^*(A; G).$$

Definition 3.1. A cochain $u \in C^q(X, G)$ has compact support if and only if there exists a compact set $K \subset X$ such that $u \in C^q(X, X - K; G)$.

Note that the set of cochains $u \in C^q(X; G)$ which have compact support is a subgroup of $C^q(X; G)$, which we will denote by $C_c^q(X; G)$. Also, if u has compact support, so does its coboundary, $\delta(u)$; hence, we obtain the cochain complex

$$C_c^*(X; G) = \{C_c^q(X, G), \delta\}.$$

We denote the q -dimensional cohomology group of this complex by $H_c^q(X; G)$; it is called the *q -dimensional cohomology group of X with compact supports*.

Obviously, if X is compact, $C_c^*(X) = C^*(X)$, and $H_c^q(X) = H^q(X)$. If X is noncompact, $H_c^q(X, G)$ is obviously a topological invariant of the space X ; however, it is definitely *not* a homotopy type invariant of X . We will have examples to illustrate this point later. It is only an invariant of what is called the *proper* homotopy type of X ; see Massey [7], p. 38.

One could now systematically develop the various properties of cohomology with compact supports. The reader who is interested in seeing this done is referred to the 1948/49 Cartan seminar notes [2, Exposé V, §6, Exposé VIII, §4 and 5, and Exposé IX, §4]; see also various books on sheaf theory. We will not do this because the singular cohomology theory with compact supports does not have such nice properties; the Čech–Alexander–Spanier cohomology with compact supports is a much more elegant theory; cf. Massey [7]. We will confine ourselves to elaborating those properties of cohomology with compact supports that are actually needed in this chapter.

There is an alternative definition of cohomology with compact supports, based on the notion of *direct limit*; the reader who is not already familiar with direct limits can quickly learn all that is needed from the appendix to [7]. We will now proceed to explain this alternative definition.

First of all, note that the compact subsets of any topological space X are partially ordered by inclusion; even more, they are *directed* by the inclusion relation because the union of any two compact subsets is compact.

Next, observe that the cochain group $C_c^q(X)$ may be looked on as the union of the subgroups $C^q(X, X - K)$, where K ranges over all compact subsets of X . In other words,

$$C_c^q(X; G) = \text{dir lim } C^q(X, X - K; G),$$

where the direct limit is taken over the above mentioned directed set, consisting of all compact subsets $K \subset X$. Now the operation of taking homology groups of a cochain complex commutes with the passage to the direct limit; therefore,

$$H_c^q(X; G) = \text{dir lim } H^q(X, X - K; G),$$

where again the direct limit is taken over all compact subsets $K \subset X$. This is the definition that we will actually use for $H_c^q(X, G)$.

EXERCISES

- 3.1. Determine the structure of the groups $H_c^i(\mathbf{R}^n; G)$ for all i . [CAUTION: Even though \mathbf{R}^n is contractible, these cohomology groups are not all trivial. Note also the structure of $H_c^0(\mathbf{R}^n)$.]
- 3.2. Let X be an arcwise connected Hausdorff space which is noncompact. What is the structure of $H_c^0(X; G)$ for any coefficient group G ?
- 3.3. A continuous map $f: X \rightarrow Y$ is said to be *proper* if the inverse image under f of any compact subset of Y is compact. Let $f: X \rightarrow Y$ be a proper continuous map, and let $f^*: C^p(Y, G) \rightarrow C^p(X, G)$ denote the induced homomorphism on cochains. Prove that $f^*(C_c^p(Y)) \subset C_c^p(X)$, and hence f induces a homomorphism of $H_c^p(Y)$ into $H_c^p(X)$.

§4. Statement and Proof of the Poincaré Duality Theorem

Let M be an n -dimensional manifold with orientation μ ; we stress that we do not need to assume that M is compact, connected, or even paracompact. Moreover, we do not need to make any hypotheses of triangulability or differentiability.

Because of the choice of orientation μ , there is singled out a unique homology class $\mu_K \in H_n(M, M - K; \mathbf{Z})$ for each compact subset K (see Theorem 2.2). Hence the cap product with μ_K defines a homomorphism

$$H^q(M, M - K; G) \rightarrow H_{n-q}(M; G)$$

by the formula

$$x \rightarrow x \cap \mu_K$$

for any $x \in H^q(M, M - K; G)$. Here the coefficient group G is arbitrary, and the cap product is defined using the natural isomorphism $G \otimes \mathbf{Z} \approx G$. Because of the naturality of the cap product, the homomorphisms thus defined for different compact sets are compatible in the following sense: if K and L are compact, and $K \subset L$, then the following diagram is commutative:

$$\begin{array}{ccc} H^q(M, M - K) & \xrightarrow{\cap \mu_K} & H_{n-q}(M) \\ \downarrow & & \uparrow \\ H^q(M, M - L) & \xrightarrow{\cap \mu_L} & H_{n-q}(M) \end{array}$$

(here the homomorphism denoted by the vertical arrow is induced by inclusion). Now it is a basic property of direct limits that any such compatible family of homomorphisms induces a homomorphism of the direct limit; thus, we have a well-defined homomorphism

$$P : H_c^q(M; G) \rightarrow H_{n-q}(M; G)$$

(the letter P stands for Poincaré).

Theorem 4.1 (Poincaré duality). *Let M be an oriented n -dimensional manifold and G an arbitrary abelian group. Then the homomorphism*

$$P : H_c^q(M; G) \rightarrow H_{n-q}(M; G)$$

is an isomorphism for all q .

We will give the proof of this theorem now, postponing the discussion of examples, special cases, and applications to later. As in the proof of Lemma 2.3, there are several cases, starting with $M = \mathbf{R}^n$, and ending with the general case.

Case 1: $M = \mathbf{R}^n$. Let B_k denote the closed ball in \mathbf{R}^n with center at the origin and radius k . Clearly, the sequence of closed balls

$$B_1, B_2, B_3, \dots$$

is cofinal in the directed set of all compact subsets of \mathbf{R}^n . It follows that

$$H_c^q(\mathbf{R}^n; G) = \text{dir lim } H^q(\mathbf{R}^n, \mathbf{R}^n - B_k; G).$$

Note also that the homomorphism

$$H^q(\mathbf{R}^n, \mathbf{R}^n - B_k) \rightarrow H^q(\mathbf{R}^n, \mathbf{R}^n - B_{k+1})$$

is an isomorphism for all k and q ; hence, it follows that

$$H_c^q(\mathbf{R}^n; G) = \begin{cases} G & \text{for } q = n \\ 0 & \text{for } q \neq n. \end{cases}$$

In view of the known structure of $H_{n-q}(\mathbf{R}^n; G)$, we see that it is indeed true that the groups $H_{n-q}(\mathbf{R}^n; G)$ and $H_c^q(\mathbf{R}^n; G)$ are isomorphic for all G and q . It only remains to prove that

$$P : H_c^n(\mathbf{R}^n; G) \rightarrow H_0(\mathbf{R}^n; G)$$

is an isomorphism; in view of the definition of P , it suffices to prove that for any closed n -dimensional ball $B \subset \mathbf{R}^n$, the homomorphism

$$H^n(\mathbf{R}^n, \mathbf{R}^n - B; G) \rightarrow H_0(\mathbf{R}^n; G)$$

defined by $x \rightarrow x \cap \mu_B$ is an isomorphism. Now μ_B is a generator of the infinite cyclic group $H_n(\mathbf{R}^n, \mathbf{R}^n - B; \mathbf{Z})$. We will complete the proof by using the following relation:

$$\varepsilon_*(x \cap \mu_B) = \langle x, \mu_B \rangle$$

(see §XIII.8). Since \mathbf{R}^n is arcwise connected, the homomorphism

$$\varepsilon_* : H_0(\mathbf{R}^n; G) \rightarrow G$$

is an isomorphism. Moreover, by the universal coefficient theorem for cohomology (see §XII.4), the homomorphism

$$\alpha : H^n(\mathbf{R}^n, \mathbf{R}^n - B; G) \rightarrow \text{Hom}(H_n(\mathbf{R}^n, \mathbf{R}^n - B); G)$$

is also an isomorphism. Using the definition of α in terms of the scalar product, the desired conclusion follows.

Case 2: Assume $M = U \cup V$, where U and V are open subsets, of M , and that Poincaré duality holds for U , V , and $U \cap V$ (it is assumed, of course, that the orientation for U is the restriction of μ to U , and similarly for V and $U \cap V$). In this situation, we can construct a Mayer–Vietoris exact sequence for cohomology with compact supports:

$$\cdots \rightarrow H_c^{q-1}(M) \rightarrow H_c^q(U \cap V) \rightarrow H_c^q(U) \oplus H_c^q(V) \rightarrow H_c^q(M) \rightarrow \cdots.$$

To construct this sequence, let $K \subset U$ and $L \subset V$ be compact sets; we then

have the following relative Mayer–Vietoris sequence, which is exact:

$$\begin{array}{c} \xrightarrow{\Delta} H^q(M, M - K \cap L) \xrightarrow{\varphi} H^q(M, M - K) \oplus H^q(M, M - L) \\ \xrightarrow{\psi} H^q(M, M - K \cup L) \end{array}$$

(we have used this Mayer–Vietoris sequence a couple of times previously in this chapter). Now by the excision property, we have the following isomorphisms:

$$\begin{aligned} H^q(M, M - K \cap L) &\approx H^q(U \cap V, U \cap V - K \cap L), \\ H^q(M, M - K) &\approx H^q(U, U - K), \end{aligned}$$

and

$$H^q(M, M - L) \approx H^q(V, V - L).$$

Next, note that as K ranges over all compact subsets of U and L ranges over all compact subsets of V , $K \cap L$ ranges over all compact subsets of $U \cap V$ and $K \cup L$ ranges over all compact subsets of M . Hence, as we pass to the direct limit over all such ordered pairs (K, L) , the direct limit of the relative Mayer–Vietoris sequences gives the desired result.

We now have the following diagram:

$$\begin{array}{ccccccc} \cdots & \longrightarrow & H_c^q(U \cap V) & \longrightarrow & H_c^q(U) \oplus H_c^q(V) & \longrightarrow & H_c^q(M) \longrightarrow \cdots \\ & & \downarrow & & \downarrow & & \downarrow \\ \cdots & \longrightarrow & H_{n-q}(U \cap V) & \longrightarrow & H_{n-q}(U) \oplus H_{n-q}(V) & \longrightarrow & H_{n-q}(M) \longrightarrow \cdots \end{array}$$

The top line of this diagram is the Mayer–Vietoris sequence we have just constructed, and the bottom line is the usual Mayer–Vietoris sequence in homology. The vertical arrows are the Poincaré duality homomorphisms for $U \cap V$, U , V , and M , respectively. We assert that *every square of this diagram is commutative*. As a general rule, it is fairly easy to check whether or not a diagram such as this is commutative. But this seems to be an exception to the general rule! The proof of commutativity is lengthy, to say the least. The complete details are given in the appendix to this chapter (see Lemma 8.2).

In any event, once we have proved commutativity for this diagram, the proof that M satisfies Poincaré duality in this case is an obvious consequence of the five-lemma.

Case 3: M is the union of a nested family of open subsets $\{U_\lambda\}$ and it is assumed that the Poincaré duality theorem holds for each of the U_λ . In order to prove this case, it is necessary to make use of a natural homomorphism

$$\tau : H_c^q(U; G) \rightarrow H_c^q(X; G)$$

which is defined as follows for any open subset U of the Hausdorff space X . If K is any compact subset of U , then the excision property guarantees us an

isomorphism

$$H^q(U, U - K) \approx H^q(X, X - K).$$

Passing to the direct limit over all compact sets $K \subset U$, we obtain the desired homomorphism (it is not an isomorphism in general because not every compact subset of X is contained in U). Two of the most important properties of τ are the following:

- (a) If $U = X$, then τ is the identity homomorphism.
- (b) If $U \subset V \subset X$, and U and V are open subsets of X , then the following diagram is commutative:

$$\begin{array}{ccc} H_c^q(U) & \longrightarrow & H_c^q(V) \\ & \searrow & \downarrow \\ & & H_c^q(X) \end{array}$$

In addition, if U is an open subset of the oriented n -manifold M , then the following diagram is commutative:

$$\begin{array}{ccc} H_c^q(U) & \xrightarrow{\tau} & H_c^q(M) \\ \downarrow P & & \downarrow P \\ H_{n-q}(U) & \xrightarrow{i_*} & H_{n-q}(M) \end{array}$$

Here $i: U \rightarrow M$ denotes the inclusion homomorphism, and as usual, the orientation of U is assumed to be the restriction of the orientation of M . The proof of the commutativity of this diagram is an easy consequence of the definition of P and the naturality of the cap product.

With these preliminaries taken care of, we can now easily prove case 3. Because the open subsets U_λ are nested, we can form the direct limits

$$\text{dir lim } H_c^q(U_\lambda)$$

and

$$\text{dir lim } H_{n-q}(U_\lambda).$$

In the first case, it is understood that the homomorphisms in the direct system of groups $\{H_c^q(U_\lambda)\}$ are the τ 's corresponding to any inclusion, whereas in the second case, they are the i_* 's corresponding to any inclusion. Next, observe that the homomorphisms

$$\begin{aligned} \tau_\lambda &: H_c^q(U_\lambda) \rightarrow H_c^q(M), \\ i_{\lambda*} &: H_{n-q}(U_\lambda) \rightarrow H_{n-q}(M) \end{aligned}$$

(which are defined for all λ) constitute a compatible collection of homomorphisms, and hence define homomorphisms of the direct limit groups:

$$\text{dir lim } H_c^q(U_\lambda) \rightarrow H_c^q(M),$$

$$\text{dir lim } H_{n-q}(U_\lambda) \rightarrow H_{n-q}(M).$$

We assert that these homomorphisms are both isomorphisms; this is a consequence of the fact that any compact subset of M is contained in some U_λ . Finally, the Poincaré duality homomorphism $P: H_c^q(U_\lambda) \rightarrow H_{n-q}(U_\lambda)$ is assumed to be an isomorphism for each λ ; it follows by passage to the direct limit that $P: H_c^q(M) \rightarrow H_{n-q}(M)$ is also an isomorphism.

Case 4: M is an open subset of \mathbf{R}^n . If M is convex, then it is homeomorphic to \mathbf{R}^n , and case 1 applies. If M is not convex, then we make use of the fact that the topology of \mathbf{R}^n has a countable basis consisting of open n -dimensional balls. Hence, M is a countable union of open balls:

$$M = \bigcup_{i=1}^{\infty} B_i.$$

Let

$$M_k = \bigcup_{i=1}^k B_i.$$

The theorem must be true for each M_k , by an obvious induction on K (use case 2). Then we can apply case 3 to conclude that the theorem is true for

$$M = \bigcup_{k=1}^{\infty} M_k.$$

Case 5: The general case. Let M be an arbitrary oriented n -manifold. Consider the family of all open subsets U of M such that Poincaré duality holds for U . This family is obviously nonempty. In view of case 3, we can apply Zorn's lemma to this family to conclude that there exists a maximal open set V belonging to it. If $V \neq M$, then there is an open subset $B \subset M$ such that B is homeomorphic to \mathbf{R}^n , and B is not contained to V . We could then apply cases 2 and 4 to conclude that Poincaré duality also holds for $V \cup B$, contradicting the maximality of V . Thus, $V = M$, and we are through. Q.E.D.

Next, we will take up the mod 2 version of the Poincaré duality theorem. While this version is weaker in that it only applies to homology and cohomology groups with \mathbf{Z}_2 coefficients, it has the advantage that it applies to all manifolds, whether orientable or not.

We will use the hypotheses and notation of Theorem 2.4: M is an arbitrary n -dimensional manifold; for each point $x \in M$, μ_x denotes the unique nonzero element of the local homology group $H_n(M, M - \{x\}; \mathbf{Z}_2)$, and for each compact subset K , μ_K denotes the unique element of $H_n(M, M - K; \mathbf{Z}_2)$ such that $\rho_x(\mu_K) = \mu_x$ for all $x \in K$. Let G be a vector space over \mathbf{Z}_2 . Define a homomorphism

$$H^q(M, M - K; G) \rightarrow H_{n-q}(M, G)$$

by the formula

$$x \rightarrow x \cap \mu_K$$

for any $x \in H^q(M, M - K; G)$ (use the natural isomorphism $G \otimes \mathbf{Z}_2 = G$ to define this cap product). The homomorphisms thus defined for all compact sets $K \subset M$ are compatible, and hence define a homomorphism of the direct limit group,

$$P_2 : H_c^q(M; G) \rightarrow H_{n-q}(M; G)$$

which we will refer to as the mod 2 Poincaré duality homomorphism.

Theorem 4.2. *For any n -dimensional manifold M and any \mathbf{Z}_2 -vector space G , the mod 2 Poincaré duality homomorphism P_2 is an isomorphism of $H_c^q(M; G)$ onto $H_{n-q}(M; G)$.*

The proof is almost word for word the same as that of Theorem 4.1; the necessary modifications are rather obvious.

EXERCISES

- 4.1. Use the Poincaré duality theorem to prove that if M is a connected, noncompact orientable n -dimensional manifold, then $H_q(M, G) = 0$ for all $q \geq n$ and all coefficient groups G .

§5. Applications of the Poincaré Duality Theorem to Compact Manifolds

Let M be a compact manifold with orientation μ ; in this case, by Theorem 2.2, there exists a unique homology class $\mu_M \in H_n(M; \mathbf{Z})$ such that $\rho_x(\mu_M) = \mu_x$ for all $x \in M$; μ_M is often referred to as *the fundamental homology class of the oriented manifold M* . The Poincaré duality isomorphism

$$P : H^q(M; G) \rightarrow H_{n-q}(M; G)$$

is defined by

$$P(x) = x \cap \mu_M$$

for any $x \in H^q(M; G)$.

We can draw some immediate conclusions from this. For example, if M is assumed to be connected, then $H_n(M; G)$ is isomorphic to G . Similarly, $H_{n-1}(M; \mathbf{Z}) \approx H^1(M; \mathbf{Z}) \approx \text{Hom}(H_1(M; \mathbf{Z}), \mathbf{Z})$ is a torsion-free group.

In case M is compact but not necessarily orientable, we can obtain similar results with \mathbf{Z}_2 coefficients. There is a unique mod 2 *fundamental class*, $\mu_M \in H_n(M; \mathbf{Z}_2)$ and the mod 2 Poincaré duality isomorphism

$$P_2 : H^q(M; \mathbf{Z}_2) \rightarrow H_{n-q}(M; \mathbf{Z}_2)$$

is defined by

$$P_2(x) = x \cap \mu_M.$$

From this isomorphism, we deduce that the rank of the vector space $H_n(M; \mathbf{Z}_2)$ (over \mathbf{Z}_2) is equal to the number of components of M .

We will now use Poincaré duality theorem to deduce some restrictions on cup products in the cohomology of a manifold.

Theorem 5.1. *Let M be a compact oriented n -manifold and F a field. Then the bilinear form*

$$H^q(M; F) \otimes H^{n-q}(M; F) \rightarrow F$$

defined by

$$u \otimes v \rightarrow \langle u \cup v, \mu_M \rangle$$

for any $u \in H^q(M; F)$ and $v \in H^{n-q}(M; F)$ is nonsingular.

PROOF. The relation

$$\langle u \cup v, \mu_M \rangle = \langle u, v \cap \mu_M \rangle$$

can be interpreted as a commutativity relation, as indicated by the following diagram:

$$\begin{array}{ccc} H^q(M; F) \otimes H^{n-q}(M, F) & & F \\ \downarrow I \otimes P & \searrow 1 & \\ H^q(M; F) \otimes H_q(M, F) & \nearrow 2 & \end{array}$$

In this diagram, arrow 1 denotes the bilinear form of the theorem, arrow 2 denotes the bilinear form defined by $x \otimes y \rightarrow \langle x, y \rangle$ for any $x \in H^q(M; F)$ and $y \in H_q(M, F)$, I denotes the identity map, and P the Poincaré duality isomorphism. The bilinear form denoted by arrow 2 is nonsingular because of the isomorphism

$$H^q(M; F) \approx \text{Hom}_F(H_q(M, F), F).$$

Since P is an isomorphism, it follows that the bilinear form denoted by arrow 1 is also nonsingular. Q.E.D.

If the manifold M is nonorientable, this theorem will still be true provided we assume that F is a field of characteristic two, e.g., $F = \mathbf{Z}_2$.

It would be nice to have an analogue of Theorem 5.1 for the case of cohomology with integer coefficients, rather than coefficients in a field. Since the groups $H^q(M; \mathbf{Z})$ and $\text{Hom}(H_q(M, \mathbf{Z}), \mathbf{Z})$ are *not* isomorphic in general, some modifications are necessary in order to obtain a valid theorem. One way

to proceed is the following: For any space X , define $B_q(X)$, the q -dimensional Betti group of X , to be the quotient group of $H_q(X; \mathbf{Z})$ modulo its torsion subgroup. Similarly, define $B^q(X)$ to be the quotient group of $H^q(X; \mathbf{Z})$ modulo its torsion subgroup. If $H_{q-1}(X; \mathbf{Z})$ is a finitely generated abelian group, then

$$B^q(X) \approx \text{Hom}(B_q(X), \mathbf{Z});$$

this is a direct consequence of the short exact sequence

$$0 \rightarrow \text{Ext}(H_{q-1}(X), \mathbf{Z}) \rightarrow H^q(X; \mathbf{Z}) \xrightarrow{\alpha} \text{Hom}(H_q(X), \mathbf{Z}) \rightarrow 0.$$

Lemma 5.2. *Let M be a compact manifold; then the integral homology group $H_q(M)$ is finitely generated for all q .*

If M could be given the structure of a CW-complex, then compactness would imply that this CW-complex was finite, and the theorem would follow. However it is not known at present whether or not all compact manifolds are CW-complexes. Fortunately, there is a way to avoid this difficulty. By results in Chapter IV, §8 of Dold, [4], a compact manifold is what is called an ENR (short for Euclidean neighborhood retract). Then Proposition V.4.11 on p. 103 of Dold [4] asserts that the homology groups of an ENR are finitely generated. Q.E.D.

Note: This follows from Poincaré duality in case M is orientable; cf. Spanier, [9, Corollary 11 at bottom of p. 298].

As a consequence of this lemma, we see that for any compact manifold M , we have a natural isomorphism

$$B^q(M) \approx \text{Hom}(B_q(M), \mathbf{Z}).$$

This isomorphism is defined as follows. Let $H^q(M; \mathbf{Z}) \otimes H_q(M, \mathbf{Z}) \rightarrow \mathbf{Z}$ be a bilinear form defined by $x \otimes y \rightarrow \langle x, y \rangle$ for $x \in H^q(M; \mathbf{Z})$ and $y \in H_q(M; \mathbf{Z})$. It is obvious that if either x or y has finite order, then $\langle x, y \rangle = 0$. Hence, there is an induced bilinear form on quotient groups:

$$B^q(M) \otimes B_q(M) \rightarrow \mathbf{Z}.$$

This bilinear form defines the desired isomorphism.

Now let us consider the bilinear form

$$H^q(M; \mathbf{Z}) \otimes H^{n-q}(M; \mathbf{Z}) \rightarrow \mathbf{Z}$$

defined by

$$u \otimes v \rightarrow \langle u \cup v, \mu_M \rangle$$

(this is similar to the bilinear form defined in Theorem 5.1). Once again, if u or v has finite order, then $\langle u \cup v, \mu_M \rangle = 0$. Hence, there is an induced bilinear form

$$B^q(M) \otimes B^{n-q}(M) \rightarrow \mathbf{Z}.$$

Theorem 5.3. *Let M be a compact, connected, oriented n -manifold. Then the bilinear form*

$$B^q(M) \otimes B^{n-q}(M) \rightarrow \mathbf{Z}$$

defined above is nonsingular and induces an isomorphism of $B^q(M)$ onto $\text{Hom}(B^{n-q}(M), \mathbf{Z})$ for all q .

The proof is very similar to that of Theorem 5.1 and may be left to the reader.

For the present, we will give one application of these theorems. Further applications will be found in the next chapter.

Proposition 5.4. *Let M be a compact, orientable manifold of dimension $n = 4k + 2$, and let F be a field of characteristic $\neq 2$. Then $H^{2k+1}(M; F)$ is a vector space over F whose dimension is even.*

PROOF. By Theorem 5.1, the bilinear form

$$H^{2k+1}(M; F) \otimes H^{2k+1}(M; F) \rightarrow F$$

defined by

$$u \otimes v \rightarrow \langle u \cup v, \mu_M \rangle$$

is nonsingular. Moreover, by the commutative law for cup products,

$$u \cup v = -v \cup u$$

for any $u, v \in H^{2k+1}(M; F)$. It follows that the bilinear form is skew-symmetric; but it is a standard theorem of algebra that nonsingular skew-symmetric bilinear forms can only exist on vector spaces of even dimension (over a field of characteristic $\neq 2$). For a proof of this theorem, see Jacobson, [5, Section 6.2].

As an example of this proposition, consider compact orientable 2-manifolds.

EXERCISES

- 5.1.** Let M be a compact, orientable n -manifold. Prove that the homology groups $H_q(M; \mathbf{Z})$ and $H_{n-q}(M; \mathbf{Z})$ have the same ranks. Also, show that the torsion subgroup of $H_q(M; \mathbf{Z})$ is isomorphic to the torsion subgroup of $H_{n-q-1}(M; \mathbf{Z})$. (NOTE: This is the way the Poincaré duality theorem was often stated before the introduction of cohomology groups about 1935. Compare Exercise XII.4.1.)
- 5.2.** Prove that the Euler characteristic of a compact n -manifold is 0 for n odd.
- 5.3.** Prove that the Euler characteristic of a compact orientable manifold of dimension $4k + 2$ is even.
- 5.4.** Let M_1 and M_2 be compact, orientable n -manifolds, and let $f: M_1 \rightarrow M_2$ be a continuous map such that the induced homomorphism

$$f_* : H_n(M_1; \mathbf{Z}) \rightarrow H_n(M_2; \mathbf{Z})$$

is an isomorphism. Prove that for any coefficient group G the induced homomorphism

$$f_* : H_q(M_1; G) \rightarrow H_q(M_2; G)$$

is an epimorphism and the kernel of f_* is a direct summand of $H_q(M_1; G)$. Similarly, prove that

$$f^* : H^q(M_2; G) \rightarrow H^q(M_1; G)$$

is a monomorphism, and the image is a direct summand of $H^q(M_1; G)$.

5.5. Let M be a compact, connected, orientable n -manifold and $f : M \rightarrow M$ a continuous map such that $f_* : H_n(M; \mathbf{Z}) \rightarrow H_n(M; \mathbf{Z})$ is an isomorphism. Prove that the induced homomorphisms $f_* : H_q(M; G) \rightarrow H_q(M; G)$ and $f^* : H^q(M; G) \rightarrow H^q(M; G)$ are isomorphisms for all q and any group G . (HINT: Do the case $G = \mathbf{Z}$ first.)

5.6. Given any even integer n , show how to construct a compact connected, orientable manifold M of dimension $4k + 2$ such that the rank of the vector space $H^{2k+1}(M; F)$ is n . (HINT: Consider first the case of 2-manifolds, i.e., $k = 0$. For larger values of k , proceed by analogy with the case $k = 0$, recalling the classification theorem for 2-manifolds.)

5.7. Let X be a Hausdorff space, and let K be a compact subset of X . Consider the cup product:

$$H^p(X; G_1) \otimes H^q(X, X - K; G_2) \xrightarrow{\cup} H^{p+q}(X, X - K; G_1 \otimes G_2).$$

Prove that passing to the direct limit over all compact subsets K of X defines a homomorphism

$$H^p(X; G_1) \otimes H_c^q(X; G_2) \rightarrow H_c^{p+q}(X; G_1 \otimes G_2).$$

(This is called the *cup product homomorphism*.)

5.8. (a) Let M be an oriented n -manifold. For any compact set $K \subset M$, let $\mu_K \in H_n(M, M - K)$ denote the unique homology class such that $\rho_x(\mu_K) = \mu_x$ for any $x \in K$. Given $u \in H_c^n(M; G)$, choose a compact set $K \subset M$ such that there exists a representative $u' \in H^n(M, M - K; G)$ for u . Show that the element

$$\langle u', \mu_K \rangle \in G$$

is independent of the choice of the representative u' for u , and that this process defines a homomorphism $H_c^n(M; G) \rightarrow G$, sometimes called *integration over M* .

(b) Show that the following diagram is commutative

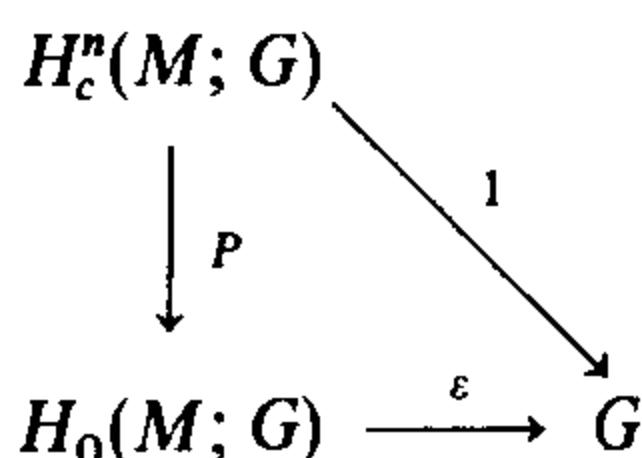

Here arrow 1 denotes integration over M .

- (c) Prove that for any elements $u \in H^p(M; G_1)$ and $v \in H_c^q(M; G_2)$, the following equation holds:

$$u \cap P(v) = P(u \cup v).$$

Here the cup product is that defined in Exercise 5.7, and P denotes the Poincaré duality isomorphism.

- (d) Let F be a field. Define a bilinear form

$$\varphi : H^{n-p}(M; F) \otimes H_c^p(M; F) \rightarrow F$$

by setting $\varphi(u \otimes v) =$ the integral of $u \cup v$ over M . Prove that this bilinear form is nonsingular and that it defines an isomorphism

$$H^{n-p}(M; F) \approx \text{Hom}_F(H_c^p(M; F), F).$$

- 5.9.** Let M^n be a compact connected orientable n -manifold and let $T : M^n \rightarrow M^n$ be a homeomorphism. How can one determine whether or not T is orientation preserving, in terms of knowledge about the induced homomorphism $T_* : H_n(M^n) \rightarrow H_n(M^n)$? (Compare Exercise 2.2)
- 5.10.** For which integers n is real projective n -space, RP^n , orientable, and for which n is it nonorientable? (For the definition of RP^n , see §IX.3; see also statement (h) in §VIII.2.)

§6. The Alexander Duality Theorem

Let A be a subset of a topological space X ; by a *neighborhood* N of A in X , we mean a subset N of X which contains A in its interior. The neighborhoods of A (ordered by inclusion) constitute a directed set since the intersection of any two neighborhoods of A is again a neighborhood of A . Consider the direct system of groups $\{H^q(N)\}$, where N ranges over all neighborhoods of A in X (the homomorphisms are those induced by the inclusion relations, of course). For each such N , the inclusion $A \subset N$ induces a homomorphism $H^q(N) \rightarrow H^q(A)$, and the collection of all such homomorphisms is obviously compatible. Hence, there is induced a homomorphism

$$\text{dir lim } H^q(N) \rightarrow H^q(A).$$

The subspace A is said to be *tautly imbedded* in X (or simply *taut* in X) with respect to singular cohomology if this homomorphism is an isomorphism for all q and all coefficient groups. This concept was introduced by Spanier [9, p. 189]. We need it for our discussion of the Alexander duality theorem.

Examples

6.1. Let A denote the subset of the plane \mathbf{R}^2 consisting of the union of the graph of the function $y = \sin(1/x)$ (for $x \neq 0$) and the y axis. We assert that A is not taut in \mathbf{R}^2 . In order to prove this, note that the open neighborhoods of A are confinal in the family of all neighborhoods of A . Furthermore, the open,

arcwise connected neighborhoods are confinal in the family of all open neighborhoods. It follows that the direct limit, $\text{dir lim } H^0(N; \mathbf{Z})$, is infinite cyclic. On the other hand, $H^0(A; \mathbf{Z})$ is free abelian of rank 3 (there are three arc components).

As another example, let P denote the subset of A consisting of one point, the origin. Then it is readily verified that P is not taut in A .

In some sense, these two examples are rather pathological. We will see shortly that any “nice” subset of a nice space is tautly imbedded. We will be mainly interested in the case where X is a manifold. Then it will turn out that the question of whether or not a subset A of X is taut or not depends only on A ! Obviously, the question only depends on arbitrarily small neighborhoods of A in X , but we are asserting something stronger than this.

The situation may be explained in more detail as follows. This book has been concerned exclusively with singular homology and cohomology theory. However, there is also another type of cohomology theory, called Čech–Alexander–Spanier cohomology theory. For any pair (X, A) , any integer q , and any abelian group G , there is defined the q -dimensional Čech–Alexander–Spanier cohomology group, which we denote by $\bar{H}^q(X, A; G)$. Just as for the singular cohomology theory, a continuous map $f: (X, A) \rightarrow (Y, B)$ induces homomorphisms $f^*: \bar{H}^q(Y, B; G) \rightarrow \bar{H}^q(X, A; G)$ for all q . The basic properties of the Čech–Alexander–Spanier cohomology theory are exactly the same as those of the singular cohomology theory; the reader may find more details in Spanier, [9, Chapter 6, Sections 4 and 5], or Massey [7, Chapter 8].

One of the major differences between singular and Alexander–Spanier cohomology is this matter of tautness. In general, tautness is more likely to hold with respect to the Alexander–Spanier cohomology theory than with respect to the singular theory. In fact, the following theorem holds:

Theorem 6.1. *In each of the following four cases A is taut in X with respect to the Alexander–Spanier cohomology theory:*

- (1) A is compact and X is Hausdorff.
- (2) A is closed and X is paracompact Hausdorff.
- (3) A is arbitrary and every open subset of X is paracompact Hausdorff.
- (4) A is a retract of some open subset of X .

This theorem is taken from Spanier [10]; for a proof, see Massey [7, pp. 238–241]. One case of this theorem is proved in Spanier [9, pp. 316–317].

A more precise comparison of singular and Alexander–Spanier cohomology is possible because there is defined for any pair (X, A) , any coefficient group G , and any integer q , a homomorphism

$$\lambda: \bar{H}^q(X, A; G) \rightarrow H^q(X, A; G).$$

This homomorphism is natural, in the sense that it commutes with homomorphisms induced by continuous maps. There are various theorems which

asserts that for certain classes of nice topological spaces, λ is an isomorphism for all G and q . For a discussion of this question, see Spanier [9, Chapter 6, Section 9], or Massey [7, §8.8]. For our purposes, the following are the two most important cases in which $\lambda : \bar{H}^q(X; G) \rightarrow H^q(X; G)$ is known to be an isomorphism for all G and q :

- (a) X a paracompact n -manifold.
- (b) X is a CW-complex, or a space which has the homotopy type of a CW-complex.

Using these properties of the homomorphism λ , we can easily prove the following propositions:

Proposition 6.2. *Let M be a paracompact n -manifold, and let A be a closed subset of M . Then A is taut in M (with respect to singular cohomology) if and only if $\lambda : \bar{H}^q(A; G) \rightarrow H^q(A; G)$ is an isomorphism for all q and G .*

Thus, in this case, the question of tautness depends only on A .

Proposition 6.3. *Let M be a paracompact n -manifold, and let A be a closed subset of M . Then*

$$\text{dir lim } H^q(N; G) \approx \bar{H}^q(A; G),$$

where the direct limit is taken over all neighborhoods N of A in M .

The proof of both of these propositions depends on the naturality of the homomorphism λ . The open neighborhoods of A are cofinal in the family of all neighborhoods of A ; and every open neighborhood N of A is also a paracompact manifold. Therefore, $\lambda : \bar{H}^q(N) \rightarrow H^q(N)$ is an isomorphism. The rest of the details of the proofs may be left to the reader.

Remark: In Dold [4], the conclusion of Proposition 6.3 is taken as the definition of the Čech–Alexander–Spanier cohomology groups $\bar{H}^q(A)$.

We will now use these results to derive important relations between the homology groups of an open subset of a compact manifold and the cohomology groups of its complement. Let M be a compact, oriented n -manifold, U an open subset of M , and $A = M - U$ the closed complement. For any compact set $K \subset U$, consider the following diagram:

$$\begin{array}{ccccccc}
 H^q(M, M - K) & \longrightarrow & H^q(M) & \longrightarrow & H^q(M - K) & \xrightarrow{\delta} & H^{q+1}(M, M - K) \\
 \downarrow k^* & & \downarrow P & & \downarrow 2 & & \downarrow k^* \\
 H^q(U, U - K) & & & & H_{n-q}(M - K, U - K) & & H^{q+1}(U, U - K) \\
 \downarrow 1 & & \downarrow & & \downarrow l_* & & \downarrow 1 \\
 H_{n-q}(U) & \xrightarrow{i_*} & H_{n-q}(M) & \xrightarrow{j_*} & H_{n-q}(M, U) & \xrightarrow{\partial} & H_{n-q-1}(U).
 \end{array}$$

In this diagram, the top line is the cohomology sequence of the pair $(M, M - K)$, the bottom line is the homology sequence of the pair (M, U) , and $k : (U, U - K) \rightarrow (M, M - K)$ and $l : (M - K, U - K) \rightarrow (M, U)$ are inclusion maps which induce isomorphisms by the excision property. The homomorphisms denoted by arrows 1 and 2 are defined by

$$\begin{aligned} x &\rightarrow x \cap (k_*^{-1} \mu_K), \\ y &\rightarrow y \cap (l_*^{-1} \mu_A) \end{aligned}$$

for any $x \in H^q(U, U - K)$ and $y \in H^q(M - K)$; here $\mu_K \in H_n(M, M - K)$ and $\mu_A \in H_n(M, M - A)$ have the same meaning as in the definition of the Poincaré duality isomorphism. In addition, each square of this diagram is commutative; this is a consequence of Lemma 8.1 in the appendix to this chapter.

Now pass to the direct limit as K ranges over all compact subsets of U . Note that

$$\text{dir lim } H^q(M - K) = \bar{H}^q(A)$$

since as K ranges over all compact subsets of U , $M - K$ ranges over all open neighborhoods of A (see Proposition 6.3). Hence, we obtain the following commutative diagram:

$$\begin{array}{ccccccc} H_c^q(U) & \xrightarrow{\tau} & H^q(M) & \xrightarrow{h^*} & \bar{H}^q(A) & \xrightarrow{\delta} & H_c^{q+1}(U) \\ \downarrow P & & \downarrow P & & \downarrow P' & & \downarrow P \\ H_{n-q}(U) & \xrightarrow{i_*} & H_{n-q}(M) & \xrightarrow{j_*} & H_{n-q}(M, U) & \xrightarrow{\partial} & H_{n-q-1}(U) \end{array} \quad (14.6.1)$$

Each square of this diagram is commutative, and the top line is exact, since direct limits preserve exactness. The vertical arrows labeled P are the Poincaré duality isomorphisms for M and U . It follows from the five-lemma that *the homomorphism labeled P' is also an isomorphism*. For future reference, we state this as follows:

Proposition 6.4. *Let M be a compact orientable n -manifold, A a closed subset of M , and $U = M - A$ the complementary set. Then the relative homology group $H_{n-q}(M, U; G)$ is isomorphic to the Čech–Alexander–Spanier cohomology group $\bar{H}^q(A; G)$.*

Of course the most interesting cases of Diagram (14.6.1) and Proposition 6.4 are those cases where the Alexander–Spanier cohomology group, $\bar{H}^q(A)$, and the singular cohomology group, $H^q(A)$, are isomorphic. In that case, it is easily verified that h^* is the homomorphism induced by the inclusion of A in M . However, the reader must not lose sight of the fact that it is absolutely necessary to use Alexander–Spanier cohomology for the correct statement of this proposition. The following example illustrates this point: Consider the 2-sphere, S^2 , as the compactification of the plane \mathbf{R}^2 , obtained by adjoining to it a point labeled ∞ . Let A be the closed subset of S^2 which is the union of

the graph of the equation $y = \sin(1/x)$ ($x \neq 0$), the segment $-1 \leq y \leq +1$ of the y axis, and the point ∞ . As above, let $U = S^2 - A = \mathbf{R}^2 - A$. Then U has two components, and it may be shown that each component is homeomorphic to an open disc. Consider the following portion of the reduced homology sequence of (S^2, U) :

$$H_1(S^2) \xrightarrow{j_*} H_1(S^2, U) \xrightarrow{\partial} \tilde{H}_0(U) \xrightarrow{i_*} \tilde{H}_0(S^2).$$

Since $\tilde{H}_0(U)$ is infinite cyclic, we deduce that $H_1(S^2, U)$ is also infinite cyclic. Hence, by Proposition 6.4, $\bar{H}^1(A)$ is infinite cyclic. On the other hand, the singular cohomology group $H^1(A)$ is zero. The set A has the same Alexander–Spanier cohomology groups as a circle, whereas its singular cohomology groups are the same as a space consisting of two points. However, the complement of A in S^2 is homeomorphic to the complement of a circle imbedded in S^2 .

Proposition 6.5. *Let A be a closed, proper subset of a compact, connected, orientable n -manifold. Then $\bar{H}^q(A; G) = 0$ for all $q \geq n$ and all coefficient groups G .*

This is a direct consequence of Proposition 6.4. It is of interest to note that this proposition is false in general for the singular cohomology groups $H^q(A; G)$; for a spectacular counterexample, see Barrett and Milnor [1].

Theorem 6.6 (Alexander duality theorem). *Let M be a compact, connected, orientable n -manifold and q an integer such that $H_q(M, G) = H_{q+1}(M, G) = 0$. Then for any closed subset $A \subset M$,*

$$\bar{H}^{n-q-1}(A; G) \approx H_q(M - A; G).$$

The most important example of a manifold satisfying the hypotheses of this theorem is the n -sphere, S^n . Obviously, we must have $0 < q < n - 1$ because $H_0(M, G)$ and $H_n(M, G)$ are always nonzero for a compact, connected, orientable n -manifold. However, there is no difficulty in stating versions of this theorem corresponding to the cases $q = 0$ and $q = n - 1$; this we will now do.

Theorem 6.6, continued. *Let M be a compact connected orientable n -manifold, and let A be a closed, proper subset of M .*

- (a) *If $H_1(M; G) = 0$, then $\bar{H}^{n-1}(A; G) \approx \tilde{H}_0(M - A; G)$.*
- (b) *$\bar{H}^0(A; G)$ always contains a direct summand isomorphic to G ; if $H_{n-1}(M; G) = 0$, then the quotient group of $\bar{H}^0(A)$ modulo this summand is isomorphic to $H_{n-1}(M - A; G)$.*

This direct summand of $\bar{H}^0(A; G)$ can be more precisely described as follows: let P denote a space consisting of one point, and let $f: A \rightarrow P$ be the unique map. Then the subgroup in question is $f^*(\bar{H}^0(P; G))$. The correspond-

ing quotient group is the “reduced” 0-dimensional Alexander–Spanier cohomology group.

The proof of the Alexander duality theorem follows immediately from Diagram (14.6.1); the details are left to the reader. The theorem can be considered a far-reaching generalization of the Jordan–Brouwer separation theorem and the other theorems which were proved in §VIII.6. Various applications of it are given in the exercises below. One of the main consequences is that if A is a closed subset of S^n , the homology groups of $S^n - A$ are independent of how A is imbedded in S^n . We have already seen special examples of this phenomenon in §VIII.6.

EXERCISES

- 6.1. Let A be a compact connected orientable $(n - 1)$ -manifold ($n > 1$) imbedded in S^n . Prove that $S^n - A$ has exactly two components.
- 6.2. Prove that a nonorientable compact $(n - 1)$ -manifold can not be imbedded in S^n . [HINT: If M is such a manifold, prove first that $H^{n-1}(M; \mathbf{Z})$ is a finite group of order 2. Then apply the Alexander duality theorem. See Exercises 2.7 and 2.11.]
- 6.3. Let A be a compact subset of \mathbf{R}^n . Derive a relation between the Alexander–Spanier cohomology groups of A and the singular homology groups of $\mathbf{R}^n - A$.
- 6.4. Let M be a compact, connected, orientable 2-manifold. We say a homology class $u \in H_1(M; \mathbf{Z})$ can be represented by an imbedded circle if there exists a subset $A \subset M$ such that A is homeomorphic to a circle, and the obvious homomorphism $H_1(A) \rightarrow H_1(M)$ sends a generator of $H_1(A; \mathbf{Z})$ onto u . Prove that if $u \neq 0$ and u can be represented by an imbedded circle, then u is not divisible [i.e., there does not exist an integer $d > 1$ and a homology class v such that $u = dv$; an equivalent condition is that the subgroup of $H_1(M)$ generated by u should be a direct summand]. Prove also that if M is a torus, every nondivisible homology class can be represented by an imbedded circle.
- 6.5. State and prove the analogues of the theorems of this section for nonorientable manifolds, using \mathbf{Z}_2 coefficients for all homology and cohomology groups.
- 6.6. Let A be a compact subset of Euclidean 3-space \mathbf{R}^3 which is tautly imbedded and has finitely generated integral homology groups. Prove that the integral homology and cohomology groups of A are torsion-free.

§7. Duality Theorems for Manifolds with Boundary

We recall the definition: An n -dimensional manifold with boundary M is a Hausdorff space such that each point has an open neighborhood homomorphic to \mathbf{R}^n , or to $\mathbf{R}_+^n = \{(x_1, \dots, x_n) \in \mathbf{R}^n \mid x_n \geq 0\}$. For simple examples of manifolds with boundary, and for the classification of compact, connected 2-dimensional manifolds with boundary, the reader is referred to Massey [6,

Chapter I, Sections 9–12]. The set of all points of M having an open neighborhood homomorphic to \mathbf{R}^n is called the *interior* of M , and the complementary set is called the *boundary* of M . Whether a point x belongs to the interior or boundary of M can be determined by means of the local homology groups of M at x (cf. §VIII.2). The interior is an open, everywhere dense subset of M , which is an n -dimensional manifold; the boundary is a closed subset which is an $(n - 1)$ -dimensional manifold.

Our main objective is to state and prove an analog of the Poincaré duality theorem for manifolds with boundary. For this purpose, it will be convenient to use the following fundamental theorem of Morton Brown:

Theorem 7.1. *Let M be a compact n -dimensional manifold with boundary B . Then there exists an open neighborhood V of B and a homeomorphism g of $B \times [0, 1)$ onto V such that $g(b, 0) = b$ for any $b \in B$.*

For a short proof of this theorem, see R. Connelly [3]. Connelly's proof is reproduced in the appendix to Vick [11].

This theorem has many consequences; among them are the following:

Corollary 7.2. *The inclusion map of $M - B$ into M is a homotopy equivalence.*

Corollary 7.3. *Let $V_t = g(B \times [0, t))$ for $0 < t < 1$, and $K_t = M - V_t$. Then V_t is an open neighborhood of B in M , B is a deformation retract of V_t , and the collection $\{K_t | 0 < t < 1\}$ is cofinal in the family of all compact subsets of $M - B$.*

Next, for $0 < t < 1$ let $i_t : (M, B) \rightarrow (M, M - K_t) = (M, V_t)$ denote the inclusion map. It follows that the induced homomorphisms

$$\begin{aligned} i_{t*} &: H_q(M, B) \rightarrow H_q(M, M - K_t), \\ i_t^* &: H^q(M, M - K_t) \rightarrow H^q(M, B) \end{aligned}$$

are isomorphisms.

Corollary 7.4. *$H_c^q(M - B; G)$ is naturally isomorphic to $H^q(M, B; G)$.*

This corollary follows from the definition of $H_c^q(M - B)$ as a direct limit, the fact that $H^q(M - B, (M - B) - K) \approx H^q(M, M - K)$ for any compact set $K \subset M - B$, and the cofinality of the family $\{K_t\}$.

We will define a manifold M with boundary B to be *oriented* if the manifold $M - B$ is oriented in the sense defined in §2. This implies that for each compact set $K \subset M - B$, there is a unique homology class $\mu_K \in H_n(M - B, M - B - K; \mathbf{Z})$ such that $\rho_x(\mu_K)$ is the local orientation of $M - B$ at x . But as was observed above,

$$H_n(M - B, M - B - K) \approx H_n(M, M - K),$$

by the excision property. In addition, if M is compact and $K = K_t$, $H_n(M, M - K) \approx H_n(M, B)$. Thus, the fact that M is oriented and compact implies the existence of a unique homology class $\mu_M \in H_n(M, B; \mathbf{Z})$ such that for any $x \in M - B$, the homomorphism $H_n(M, B) \rightarrow H_n(M, M - \{x\})$ maps μ_M onto the local orientation μ_x . μ_M is called *the fundamental homology class of M* .

Theorem 7.5. *Let M be a compact orientable n -dimensional manifold with boundary B . Then the homomorphism*

$$H^q(M, B; G) \rightarrow H_{n-q}(M; G)$$

[defined by $x \rightarrow x \cap \mu_M$ for any $x \in H^q(M, B; G)$] is an isomorphism.

PROOF. We already know that $H^q(M, B; G)$ is isomorphic to $H_{n-q}(M; G)$. For, by Corollary 7.4, $H^q(M, B) \approx H_c^q(M - B)$; then we have the Poincaré duality isomorphism $P : H_c^q(M - B) \approx H_{n-q}(M - B)$. Finally, by Corollary 7.2, there is an isomorphism $H_{n-q}(M - B) \approx H_{n-q}(M)$ induced by inclusion. Thus, it suffices to prove that the composition of these three isomorphisms is the same as the homomorphism $H^q(M, B) \rightarrow H_{n-q}(M)$ occurring in the statement of the theorem. In order to prove this, consider the following commutative diagram:

$$\begin{array}{ccccc}
 H^q(\mathcal{I}M, \mathcal{I}M - K) & \longleftarrow & H^q(M, M - K) & \longrightarrow & H^q(M, B) \\
 \otimes & & \otimes & & \otimes \\
 H_n(\mathcal{I}M, \mathcal{I}M - K) & \longrightarrow & H_n(M, M - K) & \longleftarrow & H_n(M, B) \\
 \downarrow & & \downarrow & & \downarrow \\
 H_{n-q}(\mathcal{I}M) & \longrightarrow & H_{n-q}(M) & \longleftarrow & H_{n-q}(M)
 \end{array}$$

In this diagram, $\mathcal{I}M = M - B$ denotes the interior of M , $K = K_t$, all three vertical arrows denote cap products, and all horizontal arrows denote isomorphisms which are induced by inclusion maps. The left-hand vertical arrow defines the Poincaré duality isomorphism $P : H_c^q(\mathcal{I}M) \rightarrow H_{n-q}(\mathcal{I}M)$, and the right-hand vertical arrow denotes the cap product occurring in the statement of the theorem. Putting all these facts together, the reader should have no difficulty deducing the theorem. Q.E.D.

The isomorphism of the theorem just proved is one-half of the Lefschetz–Poincaré duality theorem for manifolds with boundary. As a preliminary to the other half of this duality theorem, we need the following important result:

Theorem 7.6. *Let M be a compact, oriented, n -dimensional manifold with boundary B , and let $\partial_* : H_n(M, B; \mathbf{Z}) \rightarrow H_{n-1}(B, \mathbf{Z})$ denote the boundary operator of the pair (M, B) . Then $\partial_*(\mu_M)$ is a fundamental homology class for some orientation of B ; in particular, B is orientable.*

PROOF. In order to prove this theorem, it is necessary to show that for any $b \in B$, $j\partial_*(\mu_M)$ is a generator of the infinite cyclic group $H_{n-1}(B, B - \{b\}; \mathbf{Z})$. Here j denotes the homomorphism $H_{n-1}(B) \rightarrow H_{n-1}(B, B - \{b\})$ induced by inclusion. Note that $j\partial_* = \partial'$ is the boundary operator of the exact homology sequence of the triple $(M, B, B - \{b\})$.

By the definition of a manifold with boundary, there exists an open neighborhood U of b and a homeomorphism h of U onto \mathbf{R}_+^n . Since b is a boundary point of M , $h(b)$ must lie in the subspace of \mathbf{R}_+^n defined by the equation $x_n = 0$. Obviously, we can assume that h is chosen so that $h(b) = (0, 0, \dots, 0)$. We may as well identify each point $x \in U$ with its image $h(x) \in \mathbf{R}_+^n$; thus the coordinates x_1, \dots, x_n in \mathbf{R}_+^n are actually coordinate functions in U . Then $B \cap U$ is the subset of U defined by the equation $x_n = 0$. Let $a \in U$ be the point with coordinates $(0, \dots, 0, 1)$, and let N and W be the following subsets of U :

$$\begin{aligned} N &= \{(x_1, \dots, x_n) \in U \mid \sum x_i^2 \leq 4\}, \\ W &= \{(x_1, \dots, x_n) \in N \mid \sum x_i^2 < 4 \text{ and } x_n > 0\}, \\ E &= N \cap B. \end{aligned}$$

Now consider the following commutative diagram:

$$\begin{array}{ccccc} H_n(M, B) & \xrightarrow{\partial'} & H_{n-1}(B, B - \{b\}) & \xleftarrow{5} & H_{n-1}(E, E - \{b\}) \\ \downarrow \rho & \searrow & & \searrow & \downarrow 6 \\ H_n(M, M - \{a\}) & \xleftarrow{1} & H_n(M, M - W) & \xrightarrow{\partial_1} & H_{n-1}(M - W, (M - W) - \{b\}) \\ \uparrow 2 & & \uparrow & & \uparrow 4 \\ H_n(N, N - \{a\}) & \xleftarrow{3} & H_n(N, N - W) & \xrightarrow{\partial_2} & H_{n-1}(N - W, (N - W) - \{b\}). \end{array}$$

In this diagram, the arrows labeled ∂' , ∂_1 , and ∂_2 denote the boundary operators of certain triples; all other arrows denote homomorphisms induced by inclusion maps. It is a routine matter to prove that ∂_2 and the homomorphisms numbered 1 through 6 are isomorphisms. Thus, all the groups in the diagram, except possibly $H_n(M, B)$, are infinite cyclic, and are related by a unique isomorphism. We know that $\rho(\mu_M)$ is a generator of the infinite cyclic group $H_n(M, M - \{a\})$. It, therefore, follows that $\partial'(\mu_M)$ is a generator of the infinite cyclic group $H_{n-1}(B, B - \{b\})$, as was to be proved. Q.E.D.

We can now derive the remaining half of the Lefschetz–Poincaré duality theorem for manifolds with boundary. Let M be a compact, oriented n -dimensional manifold with boundary B , and let $\mu_M \in H_n(M, B; \mathbf{Z})$ denote the fundamental homology class of M . Consider the following diagram involving the exact homology and cohomology sequences of the pair (M, B) :

$$\begin{array}{ccccccc}
 H^q(M, B; G) & \xrightarrow{j^*} & H^q(M; G) & \xrightarrow{i^*} & H^q(B; G) & \xrightarrow{\delta} & H^{q+1}(M, B; G) \\
 \downarrow 1 & & \downarrow 2 & & \downarrow 3 & & \downarrow 1 \\
 H_{n-q}(M; G) & \xrightarrow{j_*} & H_{n-q}(M, B; G) & \xrightarrow{\delta} & H_{n-q-1}(B; G) & \xrightarrow{i_*} & H_{n-q-1}(M; G).
 \end{array}$$

In this diagram, homomorphisms denoted by arrows 1 and 2 are cap product with the fundamental class, i.e., $x \rightarrow x \cap \mu_M$. Arrow 3 denotes the Poincaré duality isomorphism for B , defined by $y \rightarrow y \cap (\partial\mu_M)$. Because of the basic properties of cap products, each square in this diagram is commutative up to a \pm sign. We have already proved that arrows 1 and 3 are isomorphisms. It follows from the five-lemma that arrow 2 is also an isomorphism. Thus, we have proved the following result:

Theorem 7.7. *Let M be a compact, oriented n -dimensional manifold with boundary B and fundamental class $\mu_M \in H_n(M, B; \mathbf{Z})$. Then there are Lefschetz–Poincaré duality isomorphisms*

$$H^q(M, B; G) \rightarrow H_{n-q}(M; G)$$

and

$$H^q(M; G) \rightarrow H_{n-q}(M, B; G)$$

defined by cap product with μ_M . In addition the homology sequence of (M, B) and the cohomology sequence of (M, B) are isomorphic as indicated in Diagram (D) above.

EXERCISES

7.1. Let M be a compact, connected, orientable n -manifold with nonempty boundary B (B need not be connected). Prove the following relations for any abelian group G :

$$H_n(M; G) = 0.$$

$$H_n(M, B; G) \approx G.$$

$H_{n-1}(M; \mathbf{Z})$ and $H_{n-1}(M, B; \mathbf{Z})$ are torsion-free abelian groups.

7.2. State and prove analogues of the theorems of this section for nonorientable manifolds with boundary, using \mathbf{Z}_2 coefficients.

7.3. Let M be a compact n -dimensional manifold with boundary B . If n is odd, prove that

$$\chi(B) = 2\chi(M) = -2\chi(M, B),$$

where χ denotes the Euler characteristic. [NOTE: It may be proved that the integral homology groups of a compact manifold with boundary are all finitely generated. Hence the Euler characteristics $\chi(M)$ and $\chi(M, B)$ are well defined.]

7.4. Let M be a compact, oriented n -dimensional manifold with boundary B . (a) For any field F , prove that the bilinear form

$$H^q(M, B; F) \otimes H^{n-q}(M; F) \rightarrow F,$$

defined by $u \otimes v \rightarrow \langle u \cup v, \mu_M \rangle$, is nonsingular (cf. Theorem 5.1). (b) By analogy with Theorem 5.2, prove that the bilinear form

$$B^q(M, B) \otimes B^{n-q}(M) \rightarrow \mathbf{Z},$$

defined by $u \otimes v \rightarrow \langle u \cup v, \mu_M \rangle$, is nonsingular.

- 7.5. Prove that the integral homology groups $H_q(M, B)$ and $H_{n-q}(M)$ have the same rank, and that the torsion subgroups of $H_q(M, B)$ and $H_{n-q-1}(M)$ are isomorphic, where (M, B) is as in the preceding exercise. (NOTE: This is the way the Lefschetz–Poincaré duality theorem was often stated before the introduction of cohomology groups about 1935.)
- 7.6. Let M be a compact, orientable $2q$ -dimensional manifold with boundary B , where q is odd, and let F be a field of characteristic $\neq 2$. Prove that the homomorphism $j^* : H^q(M, B; F) \rightarrow H^q(M; F)$ has even rank. (HINT: See the proof of Proposition 5.3.)
- 7.7. Let M_i be a manifold with boundary B_i for $i = 1, 2$. Prove that $M_1 \times M_2$ is a manifold with boundary. What is the boundary of $M_1 \times M_2$?

§8. Appendix: Proof of Two Lemmas about Cap Products

For the statement of the first lemma, assume that $\{A, B\}$ is an excisive couple in the space X , and $X = A \cup B$. We then have the following diagram of homology groups and homomorphisms:

$$H_n(A, A \cap B) \xrightarrow{e_{1*}} H_n(X, B) \xleftarrow{l_*} H_n(X) \xrightarrow{j_*} H_n(X, A) \xleftarrow{e_{2*}} H_n(B, A \cap B).$$

All homomorphisms are induced by inclusion maps; e_{1*} and e_{2*} are isomorphisms because $\{A, B\}$ is excisive. Assume that $v \in H_n(X)$ is given; let

$$v_1 = (e_{1*})^{-1} l_*(v) \in H_n(A, A \cap B),$$

$$v_2 = (e_{2*})^{-1} j_*(v) \in H_n(B, A \cap B).$$

Now consider the following diagram:

$$\begin{array}{ccccccc}
 H^q(X, A) & \xrightarrow{j^*} & H^q(X) & \xrightarrow{i^*} & H^q(A) & \xrightarrow{\delta^*} & H^{q+1}(X, A) \\
 \downarrow e_2^* & & \downarrow \cap v & & \downarrow \cap v_1 & & \downarrow e_2^* \\
 H^q(B, A \cap B) & & & & H_{n-q}(A, A \cap B) & & H^{q+1}(B, A \cap B) \\
 \downarrow \cap v_2 & & \downarrow & & \downarrow e_{1*} & & \downarrow \cap v_2 \\
 H_{n-q}(B) & \xrightarrow{k_*} & H_{n-q}(X) & \xrightarrow{l_*} & H_{n-q}(X, B) & \xrightarrow{\partial_*} & H_{n-q-1}(B).
 \end{array}$$

The top line is the exact cohomology sequence of the pair (X, A) , the bottom line is the exact homology sequence of the pair (X, B) , and the vertical arrows are induced either by the inclusion maps e_1 or e_2 , or else by cap product with the indicated homology class.

Lemma 8.1. *Each square in the above diagram is commutative.*

PROOF. In §XIII. 3, we defined a slant product

$$C^p(Y, G_1) \otimes C_q(X \times Y; G_2) \rightarrow C_{q-p}(X; G_1 \otimes G_2)$$

by the formula

$$u \setminus v = u \setminus \xi(v)$$

for any $u \in C^p(Y)$ and $v \in C_q(X \times Y)$. This slant product satisfies the following formula:

$$\partial(u \setminus v) = (\delta u) \setminus v + (-1)^p u \setminus (\partial v).$$

On passing to homology and cohomology classes, it determines a homomorphism

$$H^p(Y) \otimes H_q(X \times Y) \rightarrow H_{q-p}(X),$$

which is also called the slant product.

For the purposes of this appendix, it is convenient to define in a similar way, a cap product on the chain-cochain level. This will be a homomorphism

$$C^p(X; G_1) \otimes C_q(X; G_2) \xrightarrow{\hat{\cap}} C_{q-p}(X; G_1 \otimes G_2)$$

defined by

$$u \cap v = u \setminus d_{\#}(v),$$

where $d_{\#} : C_q(X) \rightarrow C_q(X \times X)$ is the chain map induced by the diagonal map d . It satisfies the following boundary-coboundary formula,

$$\partial(u \cap v) = (\delta u) \cap v + (-1)^p u \cap (\partial v), \tag{14.8.1}$$

for any $u \in C^p(X)$ and $v \in C_q(X)$. On passage to cohomology and homology classes, it gives rise to the cap product defined in §XIII.3. The naturality condition

$$f_{\#}((f^{\#}u) \cap v) = u \cap (f_{\#}v)$$

obviously holds for any continuous map $f : X \rightarrow X'$, $u \in C^p(X')$ and $v \in C_q(X)$. Moreover, this definition can be generalized easily to cover the case of relative chain and cochain groups which we need below.

Since $\{A, B\}$ is excisive and $X = A \cup B$, the inclusion map

$$C(A) + C(B) \rightarrow C(X)$$

induces isomorphisms on homology groups. Therefore, we can choose a representative cycle z for the homology class $v \in H_n(X)$ such that $z \in C_n(A) + C_n(B)$. In other words,

$$z = z_1 + z_2,$$

where $z_1 \in C_n(A)$ and $z_2 \in C_n(B)$. Although z is a cycle, i.e., $\partial(z) = 0$, it does not follow that z_1 and z_2 are cycles. All we can conclude is that

$$\partial(z_1) = -\partial(z_2) \in C_{n-1}(A \cap B).$$

Let $z'_1 \in C_n(A, A \cap B)$ and $z'_2 \in C_n(B, A \cap B)$ denote the images of z_1 and z_2 , respectively, in these quotient groups. Then

$$\partial(z'_1) = \partial(z'_2) = 0$$

and

$$e_{1\#}(z'_1) = l_{\#}(z), \quad e_{2\#}(z'_2) = j_{\#}(z).$$

Therefore, z'_1 and z'_2 are representative cycles for v_1 and v_2 , respectively. Now consider the following diagram of chain and cochain complexes, and chain-cochain maps:

$$\begin{array}{ccccccccc}
 0 & \longrightarrow & C^*(X, A) & \xrightarrow{j^*} & C^*(X) & \xrightarrow{i^*} & C^*(A) & \longrightarrow & 0 \\
 & & \downarrow e_2^* & & \downarrow \cap z & & \downarrow \cap z'_1 & & \\
 & & C^*(B, A \cap B) & & & & C(A, A \cap B) & & \\
 & & \downarrow \cap z'_2 & & & & \downarrow e_{1\#} & & \\
 0 & \longrightarrow & C(B) & \xrightarrow{k_{\#}} & C(X) & \xrightarrow{l_{\#}} & C(X, B) & \longrightarrow & 0
 \end{array} \tag{14.8.2}$$

Although the homomorphisms denoted by the vertical arrows do not have degree 0, they commute with the boundary and coboundary operators because z, z'_1 , and z'_2 are cycles, and because of Formula (14.8.1). The top and bottom lines of this diagram are exact. We assert that each square of this diagram is commutative. This is a consequence of the ‘‘commutativity’’ of the following diagram:

$$\begin{array}{ccccccccc}
 C^*(B, A \cap B) & \xleftarrow{e_2^*} & C^*(X, A) & \xrightarrow{j^*} & C^*(X) & = & C^*(X) & \xrightarrow{i^*} & C^*(A) \\
 \otimes & & \otimes & & \otimes & & \otimes & & \otimes \\
 C_n(B, A \cap B) & \xrightarrow{e_{2\#}} & C_n(X, A) & \xleftarrow{j_{\#}} & C_n(X) & \xrightarrow{l_{\#}} & C_n(X, B) & \xleftarrow{e_{1\#}} & C_n(A, A \cap B) \\
 \downarrow \cap & & \downarrow \cap & & \downarrow \cap & & \downarrow \cap & & \downarrow \cap \\
 C(B) & \xrightarrow{k_{\#}} & C(X) & = & C(X) & \xrightarrow{l_{\#}} & C(X, B) & \xleftarrow{e_{1\#}} & C(A, A \cap B).
 \end{array}$$

The “commutativity” of each of the four squares of this diagram expresses a naturality relation for cap products.

The proof of the lemma may now be completed by passing from Diagram (14.8.2) to the corresponding diagram of homology and cohomology groups, induced homomorphisms, etc. Q.E.D.

The statement and proof of the second lemma are somewhat longer. Assume that M is an oriented n -manifold and that $M = U \cup V$, where U and V are open subsets of M . Let K and L be compact subsets of U and V , respectively. Since M is oriented, by Theorem 2.2, there exist unique homology classes

$$\mu_{K \cup L} \in H_n(M, M - K \cup L),$$

$$\mu_K \in H_n(M, M - K),$$

$$\mu_L \in H_n(M, M - L),$$

and

$$\mu_{K \cap L} \in H_n(M, M - K \cap L)$$

which restrict to the chosen local orientations at each point. Consider the following diagram:

$$\begin{array}{ccccccc}
 \cdots & \xrightarrow{\Delta^*} & H^q(M, M - K \cap L) & \longrightarrow & H^q(M, M - K) \oplus H^q(M, M - L) & \longrightarrow & H^q(M - K \cup L) \xrightarrow{\Delta^*} \cdots \\
 & & \downarrow p^* & & \downarrow k_1^* \oplus k_2^* & & \downarrow \cap \mu_{K \cup L} \\
 & & H^q(U \cap V, U \cap V - K \cap L) & & H^q(U, U - K) \oplus H^q(V, V - L) & & \\
 & & \downarrow \cap \nu_{K \cap L} & & \downarrow (\cap \nu_K) \oplus (\cap \nu_L) & & \downarrow \\
 \cdots & \xrightarrow{\Delta_*} & H_{n-q}(U \cap V) & \longrightarrow & H_{n-q}(U) \oplus H_{n-q}(V) & \longrightarrow & H_{n-q}(M) \xrightarrow{\Delta_*} \cdots
 \end{array}$$

In the top line of this diagram, we have the relative Mayer–Vietoris cohomology sequence of the triad $(M; M - K, M - L)$, whereas the bottom line is the usual Mayer–Vietoris homology sequence. The maps

$$p : (U \cap V, U \cap V - K \cap L) \rightarrow (M, M - K \cap L),$$

$$k_1 : (U, U - K) \rightarrow (M, M - K),$$

$$k_2 : (V, V - L) \rightarrow (M, M - L)$$

are inclusion maps which induce isomorphisms on homology and cohomology by the excision property; also,

$$\nu_{K \cap L} = p_*^{-1}(\mu_{K \cap L}),$$

$$\nu_K = k_{1*}^{-1}(\mu_K),$$

$$\nu_L = k_{2*}^{-1}(\mu_L).$$

Lemma 8.2. *Each square of the above diagram is commutative.*

It is understood that the diagram is extended to the right and left indefinitely, and that the lemma applies to each square of the extended diagram.

If we pass to the direct limit over all such compact sets $K \subset U$ and $L \subset V$, we obtain a commutative diagram involving two exact sequences which played a crucial role in the proof of the Poincaré duality theorem in §4.

Lemma 8.2 is a special case of a more general lemma which we will now state. Let X_1, X_2, Y_1 , and Y_2 be subspaces of a topological space X such that $X = (\text{Interior } X_1) \cup (\text{Interior } X_2)$ and $\{Y_1, Y_2\}$ is an excisive couple. Assume we have given homology classes

$$\begin{aligned} \mu &\in H_n(X, Y_1 \cap Y_2), \\ v_\alpha &\in H_n(X_\alpha, X_\alpha \cap Y_\alpha), \quad \alpha = 1, 2, \end{aligned}$$

and

$$v \in H_n(X_1 \cap X_2, X_1 \cap X_2 \cap (Y_1 \cup Y_2))$$

such that

$$i_{\alpha*}(\mu) = k_{\alpha*}(v_\alpha)$$

and

$$q_{\alpha*}(v_\alpha) = m_{\alpha*}(v)$$

for $\alpha = 1, 2$, where

$$\begin{aligned} i_\alpha &: (X, Y_1 \cap Y_2) \rightarrow (X, Y_\alpha), \\ k_\alpha &: (X_\alpha, X_\alpha \cap Y_\alpha) \rightarrow (X, Y_\alpha), \\ q_\alpha &: (X_\alpha, X_\alpha \cap Y_\alpha) \rightarrow (X_\alpha, X_\alpha \cap (Y_1 \cup Y_2)), \end{aligned}$$

and

$$m_\alpha : (X_1 \cap X_2, X_1 \cap X_2 \cap (Y_1 \cup Y_2)) \rightarrow (X_\alpha, X_\alpha \cap (Y_1 \cup Y_2))$$

are all inclusion maps. Consider the following diagram:

$$\begin{array}{ccccccc} H^q(X, Y_1 \cup Y_2) & \xrightarrow{\Phi} & H^q(X, Y_1) \oplus H^q(X, Y_2) & \xrightarrow{\Psi} & H^q(X, Y_1 \cap Y_2) & \xrightarrow{\Delta^*} & H^{q+1}(X, Y_1 \cup Y_2) \\ \downarrow \alpha & & \downarrow \beta & & \downarrow \gamma & & \downarrow \alpha \\ H_{n-q}(X_1 \cap X_2) & \xrightarrow{\Phi'} & H_{n-q}(X_1) \oplus H_{n-q}(X_2) & \xrightarrow{\Psi'} & H_{n-q}(X) & \xrightarrow{\Delta_*} & H_{n-q-1}(X_1 \cap X_2). \end{array}$$

The top line is the relative Mayer–Vietoris cohomology sequence of the triad $(X; Y_1, Y_2)$, whereas the bottom line is the usual Mayer–Vietoris homology sequence. The homomorphisms α, β , and γ are defined as follows:

$$\begin{aligned} \alpha(x) &= (p^*x) \cap v, \quad x \in H^*(X, Y_1 \cup Y_2), \\ \beta(u, v) &= ((k_1^*u) \cap v_1, (k_2^*v) \cap v_2), \quad u \in H^*(X, Y_1), v \in H^*(X, Y_2) \\ \gamma(w) &= w \cap \mu, \quad w \in H^*(X, Y_1 \cap Y_2). \end{aligned}$$

Here $p : (X_1 \cap X_2, X_1 \cap X_2 \cap (Y_1 \cup Y_2)) \rightarrow (X, Y_1 \cup Y_2)$ is an inclusion. From the basic properties of cap products, it is easy to check that the squares 1 and 2 in the above diagram are commutative. However, square 3 need *not* be commutative. In fact, we have the following precise statement:

Lemma 8.3. *There exists a homology class $y \in H_{n+1}(X, Y_1 \cup Y_2)$ such that for any integer q and any $w \in H^q(X, Y_1 \cap Y_2)$,*

$$\Delta_* \gamma(w) - \alpha \Delta^*(w) = \Delta_*((\Delta^*w) \cap y)$$

(the homology class y is not unique, in general).

Before proving this lemma, we will indicate how it implies Lemma 8.2. Let

$$\begin{aligned} X &= M, & X_1 &= U, & X_2 &= V, \\ Y_1 &= M - K, & \text{and} & & Y_2 &= M - L. \end{aligned}$$

Then $H_{n+1}(X, Y_1 \cup Y_2) = H_{n+1}(M, M - K \cap L) = 0$ since M is an n -dimensional manifold. Hence $y = 0$ in this case, and Lemma 8.2 follows.

PROOF OF LEMMA 8.3. The standard situation which leads to a commutative diagram of exact sequences is the following:

$$\begin{array}{ccccccccc} 0 & \longrightarrow & K' & \xrightarrow{i} & K & \xrightarrow{j} & K'' & \longrightarrow & 0 \\ & & \downarrow \varphi' & & \downarrow \varphi & & \downarrow \varphi'' & & \\ 0 & \longrightarrow & L' & \xrightarrow{k} & L & \xrightarrow{l} & L'' & \longrightarrow & 0 \end{array} \tag{14.8.3}$$

In this diagram, the following two hypotheses are assumed:

- (i) The top and bottom lines are short exact sequences of chain complexes and chain maps.
- (ii) The chain maps φ' , φ , and φ'' satisfy the following commutativity relations:

$$\varphi i = k \varphi' \quad \text{and} \quad \varphi'' j = l \varphi.$$

Unfortunately, this situation does not apply to the case at hand, because neither of these two hypotheses holds when we go back to chains and cochains. In order to prove Lemma 8.3, it is necessary to investigate what happens when we relax these hypotheses. The first (and more interesting) step is to relax the commutativity condition (ii) and require only commutativity up to a chain homotopy. To be precise, assume that the following chain homotopy relations hold in the above diagram:

$$\begin{aligned} \varphi i - k \varphi' &= \partial D + D \partial', \\ \varphi'' j - l \varphi &= \partial'' E + E \partial, \end{aligned}$$

where $D : K' \rightarrow L$ and $E : K \rightarrow L''$ are homomorphisms of degree $+1$. An easy

calculation then shows that

$$\partial''(Ei + lD) = -(Ei + lD)\partial',$$

i.e., the homomorphism $Ei + lD : K' \rightarrow L''$ commutes with the boundary operator (up to a minus sign). Therefore, it induces homomorphisms

$$(Ei + lD)_* : H_{q-1}(K') \rightarrow H_q(L'')$$

for all q . We assert that this homomorphism gives us a measure of the lack of commutativity of the following diagram:

$$\begin{array}{ccccccc} \dots & \xrightarrow{j_*} & H_q(K'') & \xrightarrow{\partial_K} & H_{q-1}(K') & \xrightarrow{i_*} & \dots \\ & & \downarrow \varphi''_* & & \downarrow \varphi'_* & & \\ \dots & \xrightarrow{l_*} & H_q(L'') & \xrightarrow{\partial_L} & H_{q-1}(L') & \xrightarrow{k_*} & \dots \end{array}$$

In fact, the following equation holds:

$$\partial_L \varphi''_* - \varphi'_* \partial_K = \partial_L (Ei + lD)_* \partial_K. \tag{14.8.4}$$

To prove this equation, one must prove that for any $u \in H_q(K'')$,

$$\varphi'_* \partial_K(u) = \partial_L(\varphi''_*(u) - (Ei + lD)_* \partial_K(u)).$$

Choose a representative cycle for the homology class u , and then compute representative cycles for the left- and right-hand side of this equation. We leave it to the reader to verify that the two representative cycles are homologous.

Next, we will consider relaxing hypothesis (i), the exactness hypothesis. We will assume given a diagram

$$K' \xrightarrow{i} K \xrightarrow{j} K''$$

of chain complexes and chain maps such that i is a monomorphism, j is an epimorphism, and image i is contained in kernel j . However, we do *not* assume that image $i = \text{kernel } j$; this is the assumption we have to avoid. We also have to consider the following two additional chain complexes:

$$\mathcal{K}(j) = \text{kernel } j,$$

$$\mathcal{C}(i) = \text{cokernel } i.$$

We then have the following commutative diagram of chain complexes and chain maps:

$$\begin{array}{ccccccccc} 0 & \longrightarrow & K' & \xrightarrow{i} & K & \longrightarrow & \mathcal{C}(i) & \longrightarrow & 0 \\ & & \downarrow \alpha & & \parallel & & \downarrow \beta & & \\ 0 & \longrightarrow & \mathcal{K}(j) & \longrightarrow & K & \xrightarrow{j} & K'' & \longrightarrow & 0 \end{array}$$

Each row of this diagram is exact. Using the five-lemma, it is readily seen that

$\alpha_* : H_q(K') \rightarrow H_q(\mathcal{K}(j))$ is an isomorphism for all q if and only if $\beta_* : H_q(\mathcal{C}(i)) \rightarrow H_q(K'')$ is an isomorphism for all q . If that is the case, we can define a long exact homology sequence

$$\cdots \rightarrow H_q(K') \xrightarrow{i_*} H_q(K) \xrightarrow{j_*} H_q(K'') \xrightarrow{\partial_*} H_{q-1}(K') \rightarrow \cdots$$

in a natural way.

Let us agree to say that the sequence of chain complexes and chain maps

$$K' \xrightarrow{i} K \xrightarrow{j} K''$$

is *almost exact* if all the assumptions listed in the preceding paragraph (including that α_* and β_* are isomorphisms) hold. The point is that almost exact sequences are just as good as short exact sequences when it comes to defining long exact homology sequences.

Examples

8.1. Assume that $\{A, B\}$ is an excisive couple in the space X . We then have the following almost exact sequence of chain complexes,

$$C(X, A \cap B) \rightarrow C(X, A) \oplus C(X, B) \rightarrow C(X, A \cup B)$$

which gives rise to the relative Mayer–Vietoris homology sequence (cf. XIII.6). The dual sequence of cochain complexes,

$$C^*(X, A \cup B; G) \rightarrow C^*(X, A; G) \oplus C^*(X, B; G) \rightarrow C^*(X, A \cap B)$$

is also almost exact, and gives rise to the relative Mayer–Vietoris sequence in cohomology.

We will now apply these ideas to generalize Diagram (14.8.3) and Equation (14.8.4). Assume we have given the following diagram of chain complexes and chain maps:

$$\begin{array}{ccccc} K' & \xrightarrow{i} & K & \xrightarrow{j} & K'' \\ \downarrow \varphi' & & \downarrow \varphi & & \downarrow \varphi'' \\ L' & \xrightarrow{k} & L & \xrightarrow{l} & L'' \end{array} \tag{14.8.5}$$

It is assumed that both rows of this diagram are almost exact (instead of exact), and that each square is chain-homotopy commutative; in other words, there exist chain homotopies $D : K' \rightarrow L$ and $E : K \rightarrow L''$ such that

$$\begin{aligned} \varphi i - k \varphi' &= \partial D + D \partial', \\ \varphi'' j - l \varphi &= \partial'' E + E \partial. \end{aligned}$$

Then, exactly as before, we can verify that the homomorphism

$$Ei + lD : K' \rightarrow L''$$

commutes with the boundary operators (up to a minus sign) and induces homomorphisms

$$(Ei + lD)_* : H_{q-1}(K') \rightarrow H_q(L'')$$

Then this homomorphism suffices to describe the lack of commutativity in the following diagram:

$$\begin{array}{ccc} H_q(K'') & \xrightarrow{\partial_K} & H_{q-1}(K') \\ \downarrow \varphi_*'' & & \downarrow \varphi_*' \\ H_q(L'') & \xrightarrow{\partial_L} & H_{q-1}(L') \end{array}$$

by means of the following equation:

$$\partial_L \varphi_*'' - \varphi_*' \partial_K = \partial_L (Ei + lD)_* \partial_L \tag{14.8.6}$$

PROOF OF EQUATION (14.8.6). Consider the following diagram:

$$\begin{array}{ccccc} K' & \xrightarrow{i} & K & \longrightarrow & \mathcal{C}(i) \\ \downarrow \varphi' & & \downarrow \varphi & \searrow j & \downarrow \beta \\ L' & & & & K'' \\ \downarrow \alpha & \searrow k & & & \downarrow \varphi'' \\ \mathcal{K}(l) & \longrightarrow & L & \xrightarrow{l} & L'' \end{array}$$

It follows that we can write down the analog of Equation (14.8.4) for the following diagram:

$$\begin{array}{ccccc} K' & \xrightarrow{i} & K & \longrightarrow & \mathcal{C}(i) \\ \downarrow \alpha\varphi' & & \downarrow & & \downarrow \varphi''\beta \\ \mathcal{K}(l) & \longrightarrow & L & \xrightarrow{l} & L'' \end{array}$$

Since α_* and β_* are isomorphisms, Equation (14.8.6) is then an easy consequence. Q.E.D.

We are now ready to apply these ideas to prove Lemma 8.3. Choose representative cycles

$$\begin{aligned} \mu' &\in C_n(X, Y_1 \cup Y_2), \\ v'_\alpha &\in C_n(X_\alpha, X_\alpha \cap Y_\alpha), \quad \alpha = 1, 2, \\ v' &\in C_n(X_1 \cap X_2, X_1 \cap X_2 \cap (Y_1 \cup Y_2)) \end{aligned}$$

for the homology classes μ , v_α , and v , respectively. Now consider the following

diagram of chain and cochain complexes, and chain maps:

$$\begin{array}{ccccc}
 C^*(X, Y_1 \cup Y_2) & \xrightarrow{\varphi} & C^*(X, Y_1) \oplus C^*(X, Y_2) & \xrightarrow{\Psi} & C^*(X, Y_1 \cap Y_2) \\
 \downarrow \alpha' & & \downarrow \beta' & & \downarrow \gamma' \\
 C(X_1 \cap X_2) & \xrightarrow{\varphi'} & C(X_1) \oplus C(X_2) & \xrightarrow{\Psi'} & C(X_1) + C(X_2)
 \end{array}$$

The homomorphisms in this diagram are defined as follow (see the diagram at the end of the proof):

$$\begin{aligned}
 \varphi(x) &= (j_1^\# x, j_2^\# x), \quad x \in C^*(X, Y_1 \cup Y_2), \\
 \alpha'(x) &= (p^\# x) \cap \nu', \quad x \in C^*(X, Y_1 \cup Y_2), \\
 \psi(u, v) &= i_1^\# u - i_2^\# v, \quad u \in C^*(X, Y_1), v \in C^*(X, Y_2), \\
 \beta(u, v) &= ((k_1^\# u) \cap \nu'_1, (k_2^\# v) \cap \nu'_2), \quad u \in C^*(X, Y_1), v \in C^*(X, Y_2), \\
 \gamma'(w) &= w \cap \mu', \quad w \in C^*(X, Y_1 \cap Y_2), \\
 \varphi(x) &= (m_1 x, m_2 x), \quad x \in C(X_1 \cap X_2), \\
 \psi'(u, v) &= k'_1 u - k'_2 v, \quad u \in C(X_1), v \in C(X_2).
 \end{aligned}$$

The top line is almost exact; on passage to cohomology, one obtains the relative Mayer–Vietoris sequence. The bottom line is exact; on passage to homology, it gives the usual Mayer–Vietoris sequence. At the right end of the bottom line, $C(X_1) + C(X_2)$ denotes the chain subcomplex of $C(X)$ generated by $C(X_1)$ and $C(X_2)$. In order that the image of γ' lie in this subcomplex, we assume that the representative cycle μ' is a linear combination of singular cubes which the “small of order \mathcal{U} ,” where $\mathcal{U} = \{X_1, X_2\}$.

It is readily verified that α' , and β' , and γ' are chain maps. Moreover, both squares of this diagram are chain homotopy commutative. Explicit chain homotopies may be defined as follows. The hypothesis that $i_{\alpha*}(\mu) = k_{\alpha*}(\nu_\alpha)$ implies the existence of chains

$$a_\alpha \in C_{n+1}(X, Y_\alpha), \quad \alpha = 1, 2,$$

such that

$$\partial a_\alpha = i_{\alpha\#}(\mu') - k_{\alpha\#}(\nu').$$

Similarly, the hypothesis that $q_{\alpha*}(\nu_\alpha) = m_{\alpha*}(\nu')$ implies the existence of chains

$$b_\alpha \in C_{n+1}(X_\alpha, X_\alpha \cap (Y_1 \cup Y_2))$$

such that

$$\partial b_\alpha = q_{\alpha\#}(\nu'_\alpha) - m_{\alpha\#}(\nu').$$

Then one defines chain homotopies

$$\begin{aligned}
 D &: C^*(X, Y_1 \cup Y_2) \rightarrow C(X_1) \oplus C(X_2), \\
 E &: C^*(X, Y_1) \oplus C^*(X, Y_2) \rightarrow C(X_1) + C(X_2)
 \end{aligned}$$

by the formulas

$$D(x) = (-1)^{|x|}((n_1^\# x) \cap b_1, (n_2^\# x) \cap b_2),$$

$$E(u, v) = (-1)^{|u|}(u \cap a_1 - v \cap a_2).$$

It is then easy to verify that

$$\beta' \varphi - \varphi' \alpha' = \partial D + D \delta,$$

$$\gamma' \psi - \psi' \beta' = \partial E + E \delta$$

as required. Thus, we are in the situation described in Diagram (14.8.5), and Formula (14.8.6) is applicable. Using the definition of D and E above, and the naturality properties of the cap product, an easy computation gives the following formula:

$$(E\varphi + \psi'D)(x) = (-1)^{|x|}x \cap y'$$

for any $x \in C^*(X, Y_1 \cup Y_2)$, where

$$y' = j_{1\#}a_1 + n_{1\#}b_1 - j_{2\#}a_2 - n_{2\#}b_2.$$

In view of the way the chains $a_1, a_2, b_1,$ and b_2 were chosen, it is easy to check that $\partial y' = 0$, i.e., y' is a cycle. Let $y \in H_{n+1}(X, Y_1 \cup Y_2)$ denote the homology class of y' ; then it follows from Formula (14.8.6) that $\pm y$ has the properties stated in Lemma 8.3; this completes the proof. To assist the reader in following the above proof, we offer the following commutative diagram of the chain complexes and chain maps which occur in the above proof:

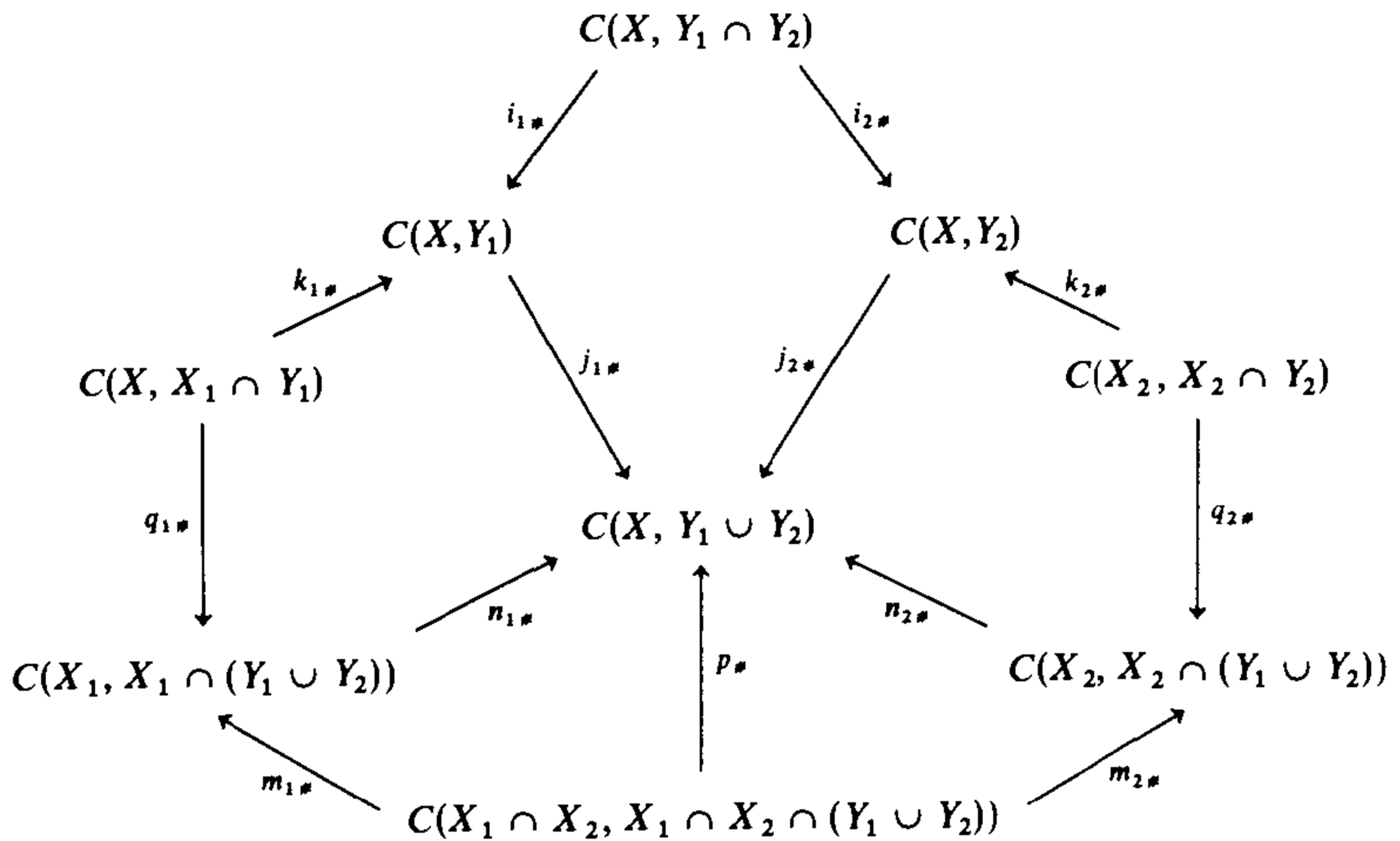

All chain maps in this diagram are induced by inclusion maps.

Remark: The homology class y is not unique; for, the chains $a_1, a_2, b_1,$ and b_2 can each be changed by adding a cycle from the chain group to which it belongs. We leave it to the interested reader to investigate in more detail the indeterminacy of the homology class y .

NOTES

In his first paper on analysis situs in 1895, Poincaré asserted that if M is a compact, orientable n -manifold, then the ranks of the homology groups $H_q(M)$ and $H_{n-q}(M)$ are the same. Of course, his proof of this assertion was not rigorous even by the standards of the nineteenth century.

Alexander first stated and proved his famous duality theorem in a paper in volume 23 of the *Transactions of the American Mathematical Society* (1922) in essentially the following form: Let X be a subset of S^n which is a finite CW -complex. Then the homology groups $\tilde{H}_q(X; \mathbf{Z}_2)$ and $\tilde{H}_{n-q-1}(S^n - X; \mathbf{Z}_2)$ have the same rank as \mathbf{Z}_2 -vector spaces [the \mathbf{Z}_2 -rank of $H_q(X, \mathbf{Z}_2)$ is called the q^{th} connectivity number of X].

In those days there was no possibility of stating the conclusion of the Poincaré or Alexander duality theorems as an assertion that certain groups were isomorphic because algebraic topology at that time was concerned with Betti numbers, torsion coefficients, and connectivity numbers rather than homology groups (see the Notes at the end of Chapter VIII). By 1930, when the group-theoretic point of view became dominant, giving a more natural statement to these duality theorems was obviously an important problem. Much effort and ingenuity was expended on this problem; for example, it seems likely that L. Pontrjagin was motivated to prove his famous duality theorem for abelian topological groups in order to be able to state the Alexander duality theorem in full generality using only homology groups. A truly neat and general statement of the duality theorems eluded topologists until the introduction of cohomology groups made possible the type of statements in this chapter.

An extension of Poincaré duality to manifolds with boundary was first given by S. Lefschetz in 1926.

Intersection theory for the homology of manifolds

Let M be a compact, oriented n -dimensional manifold, and let $P : H^q(M, \mathbf{Z}) \rightarrow H_{n-q}(M, \mathbf{Z})$ denote the Poincaré duality isomorphism. Given homology classes $u \in H_p(M, \mathbf{Z})$ and $v \in H_q(M, \mathbf{Z})$, we define their *intersection*, $u \circ v \in H_{p+q-n}(M, \mathbf{Z})$, by

$$u \circ v = P[(P^{-1}u) \cup (P^{-1}v)].$$

It follows that this operation has the same basic algebraic properties as the cup product, i.e., it is an associative, distributive product, which is commutative up to a \pm sign. Since it is derived from the cup product via the Poincaré duality isomorphism, it is unlikely to give any information that is not already obtainable from cup products. However, this homology operation is of great historical interest: in the mid-1920s, a direct definition of the intersection of two homology classes in an oriented manifold was given by two American topologists, J. W. Alexander and especially S. Lefschetz. This was a full decade

before the development of cohomology theory and cup products. Their method used a very basic and simple geometric idea. It is easily verified that two linear subspaces of Euclidean n -space, of dimensions p and q , respectively, intersect in a linear subspace of dimension $p + q - n$, provided the subspaces are in “general position” (this could be taken as a definition of general position). Now suppose we are given homology classes $u \in H_p(M)$ and $v \in H_q(M)$, as above. Lefschetz pointed out that one can choose representative cycles u' and v' , respectively, so that u' and v' are in “general position.” This condition means that locally the situation should be like that of linear subspaces of dimensions p and q in \mathbf{R}^n which are in general position. Under this condition, Lefschetz showed that the intersection of u' and v' (in the sense of point set topology) could be assigned an orientation and multiplicity (see §VI.3) so it becomes a cycle of dimension $p + q - n$. Then Lefschetz defined $u \circ v$ to be the homology class of this cycle. To show that this definition is independent of all the choices which must be made, that it is topologically invariant, and to establish its properties would be a formidable task. Just before World War II, L. Pontrjagin assigned it to a student of his, M. Glezerman. Unfortunately Glezerman was killed fighting during the War, but his paper was published in 1947 (see *American Mathematical Society Translation* No. 50 (1951) entitled “Intersections in Manifolds” by Glezerman and Pontrjagin). It takes 150 pages just to establish the basic properties and there are no applications. In the Introduction, the authors remark that,

“The whole theory is very cumbersome and Lefschetz has not carried it out very concretely.”

Although intersection theory in manifolds is mainly of historical interest today, it is still of some value in aiding our geometric intuition about cocycles and cup products, at least in the case of manifolds. A good example to consider in this regard is n -dimensional complex projective space, CP^n . The cohomology and cup products in CP^n are determined in the next chapter. The reader who has some knowledge of projective geometry can work out the intersection theory for the homology of CP^n , and check the assertions of the preceding paragraph for this particular example.

References

1. M. Barratt and J. Milnor, An example of anomalous singular homology, *Proc. Am. Math. Soc.* **13** (1962), 293–297.
2. H. Cartan, *Seminaire Henri Cartan 1948/49: Topologie Algébrique*, W. A. Benjamin, Inc., New York, 1967.
3. R. Connelly, A new proof of Brown’s collaring theorem, *Proc. Am. Math. Soc.* **27** (1971), 180–182.
4. A. Dold, *Lectures on Algebraic Topology*, Springer-Verlag, New York, 1972.
5. N. Jacobson, *Basic Algebra I*, W. H. Freeman and Co., San Francisco, 1974.

6. W. S. Massey, *Algebraic Topology: An Introduction*, Springer-Verlag, New York, 1978.
7. W. S. Massey, *Homology and Cohomology Theory: An Approach Based on Alexander–Spanier Cochains*, Marcel Dekker, Inc., New York, 1978.
8. J. Milnor, *Lectures on Characteristic Classes*, Princeton University Press, Princeton, N.J., 1974.
9. E. Spanier, *Algebraic Topology*, McGraw-Hill, New York, 1966.
10. E. Spanier, Tautness for Alexander–Spanier cohomology, *Pac. J. Math.* **75** (1978), 561–563.
11. J. Vick, *Homology Theory*, Academic Press, New York, 1973.

CHAPTER XV

Cup Products in Projective Spaces and Applications of Cup Products

§1. Introduction

In this chapter we will determine cup products in the cohomology of the real, complex, and quaternionic projective spaces. The cup products (mod 2) in real projective spaces will be used to prove the famous Borsuk–Ulam theorem. Then we will introduce the mapping cone of a continuous map, and use it to define the Hopf invariant of a map $f: S^{2n-1} \rightarrow S^n$. The proof of existence of maps of Hopf invariant 1 will depend on our determination of cup products in the complex and quaternionic projective plane.

§2. The Projective Spaces

We defined the n -dimensional real, complex, and quaternionic projective spaces (denoted by RP^n , CP^n , and QP^n , respectively) in §IX.3. We also defined CW-complex structures on them, and then determined the homology groups of CP^n and QP^n . Now we are going to prove that they are compact, connected manifolds, and then use the Poincaré duality theorem to determine the cup products in their cohomology.

Since the universal covering space of RP^n is S^n , it is clear that RP^n is a compact, connected manifold (see Exercise 2.1 in the preceding chapter).

Next, we will prove that CP^n is a $2n$ -dimensional manifold. Let (z_0, z_1, \dots, z_n) denote homogeneous coordinates in CP^n (see IX.3), and let

$$U_i = \{(z_0, \dots, z_n) \in CP^n \mid z_i \neq 0\}$$

for $i = 0, 1, \dots, n$. Then U_i is an open subset of CP^n . We may “normalize” the

homogeneous coordinates of a point in U_i by requiring that $z_i = 1$. With this normalization, each point of U_i has unique homogeneous coordinates. These unique coordinates define an obvious homomorphism of U_i with $\mathbf{C}^n = \mathbf{R}^{2n}$. Since the collection of sets $\{U_i | i = 0, 1, \dots, n\}$ is clearly a covering of CP^n , this suffices to prove that CP^n is a $2n$ -manifold.

Remark: In the preceding paragraph, we have neglected various details of point set topology which arise because of the fact that CP^n is defined as a quotient space. The reader can either work these details out for himself, or consult some reference such as Bourbaki [3].

That CP^n is compact and connected follows from the CW-complex defined on it in §IX.3.

An analogous proof, using quaternions instead of complex numbers, shows that QP^n is a compact, connected manifold of dimension $4n$.

A method of proving that RP^n is orientable for n odd and nonorientable for n even is outlined in Exercises 2.2 to 2.5, of Chapter XIV. We will not make use of this result in this chapter, except in the exercises. In §IX.4, we proved that the integral homology groups $H_{2n}(CP^n)$ and $H_{4n}(QP^n)$ are infinite cyclic. This implies that CP^n and QP^n are orientable for all n .

We will now discuss cup products in these projective spaces. For the sake of brevity, it will be convenient to write uv instead of $u \cup v$. For any integer $n \geq 1$, u^n will denote the product $uu \cdots u$ (n factors), while $u^0 = 1$.

In order to describe cup products in the cohomology of CP^n and QP^n , note that

$$H^i(CP^n; \mathbf{Z}) \approx \begin{cases} \mathbf{Z} & \text{for } i \text{ even and } 0 \leq i \leq 2n \\ 0 & \text{otherwise.} \end{cases}$$

This follows from determination of the homology of CP^n in §IX.4 and the universal coefficient theorem. Similarly,

$$H^i(QP^n; \mathbf{Z}) \approx \begin{cases} \mathbf{Z} & \text{for } i \equiv 0 \pmod{4} \text{ and } 0 \leq i \leq 4n \\ 0 & \text{otherwise.} \end{cases}$$

Theorem 2.1. *Let u be a generator of the infinite cyclic group $H^2(CP^n; \mathbf{Z})$. Then u^k is a generator of $H^{2k}(CP^n; \mathbf{Z})$ for $0 \leq k \leq n$.*

Theorem 2.2. *Let v be a generator of $H^4(QP^n; \mathbf{Z})$. Then v^k is a generator of the infinite cyclic group $H^{4k}(QP^n; \mathbf{Z})$ for $0 \leq k \leq n$.*

PROOF OF THEOREM 2.1. The proof is by induction on n , using Theorem 5.2 of the preceding chapter. For $n = 1$, the theorem is a triviality, whereas for $n = 2$, it follows directly from Theorem XIV.5.2. Assume that the theorem is true for CP^n , $n \geq 2$; we will show this implies the theorem for CP^{n+1} .

In §IX.3, we defined a structure of CW-complex on CP^{n+1} , such that the

skeleton of dimension $2k$ is CP^k for $0 \leq k \leq n + 1$. From this it follows that we may consider CP^n as a closed subspace of CP^{n+1} , and the relative cohomology groups of the pair (CP^{n+1}, CP^n) are given by

$$H^k(CP^{n+1}, CP^n; \mathbf{Z}) = \begin{cases} \mathbf{Z} & \text{for } k = 2n + 2 \\ 0 & \text{otherwise.} \end{cases}$$

Let $i: CP^n \rightarrow CP^{n+1}$ denote the inclusion map; from the exact cohomology sequence we deduce that

$$i^*: H^k(CP^{n+1}; \mathbf{Z}) \rightarrow H^k(CP^n; \mathbf{Z})$$

is an isomorphism for all $k \neq 2n + 2$. Let u denote a generator of $H^2(CP^{n+1}; \mathbf{Z})$; by the inductive hypothesis, $(i^*u)^k$ is a generator of $H^{2k}(CP^n; \mathbf{Z})$ for $0 \leq k \leq n$; it follows that u^k is a generator of $H^{2k}(CP^{n+1}; \mathbf{Z})$ for the same values of k . By applying Theorem XIV.5.2 to the cup product

$$H^{2n}(CP^{n+1}; \mathbf{Z}) \otimes H^2(CP^{n+1}; \mathbf{Z}) \rightarrow H^{2n+2}(CP^{n+1}; \mathbf{Z}),$$

we conclude that u^{n+1} is a generator of $H^{2n+2}(CP^{n+1})$, completing the inductive step. Q.E.D.

The proof of Theorem 2.2 is similar and is left to the reader. To obtain an analogous result for real projective space, RP^n , it is necessary to use mod 2 cohomology.

Theorem 2.3. *The mod 2 cohomology group $H^k(RP^n; \mathbf{Z}_2)$ is cyclic of order 2 for $0 \leq k \leq n$. If w is a generator of $H^1(RP^n; \mathbf{Z}_2)$, then w^k is a generator of $H^k(RP^n; \mathbf{Z}_2)$ for $0 \leq k \leq n$.*

PROOF. Once again the proof is by induction on n , using the CW-complex structure on RP^n which is given in §IX.3. The theorem is true for $n = 1$, because RP^1 is homomorphic to S^1 . We determined the integral homology groups of RP^2 in §VIII.4; from this one can show that $H^k(RP^2; \mathbf{Z}_2) = \mathbf{Z}_2$ for $k = 0, 1, 2$. Determination of the cup products in $H^*(RP^2; \mathbf{Z}_2)$ then follows from the analog for nonorientable manifolds of Theorem 5.1 of the preceding chapter.

The inductive step is slightly more complicated than that in the proof of Theorem 2.1. Recall that RP^n is a CW-complex with one cell in each dimension $\leq n$, and the k -skeleton is RP^k for $0 \leq k \leq n$. It follows that

$$H^k(RP^n, RP^{n-1}; \mathbf{Z}_2) = \begin{cases} \mathbf{Z}_2 & \text{for } k = n \\ 0 & \text{for } k \neq n. \end{cases}$$

From this it follows that

$$i^*: H^k(RP^n; \mathbf{Z}_2) \rightarrow H^k(RP^{n-1}; \mathbf{Z}_2)$$

is an isomorphism for $k < n - 1$. We will prove that it is also an isomorphism

for $k = n - 1$. Consider the following portion of the mod 2 exact cohomology sequence of the pair (RP^n, RP^{n-1}) :

$$0 \rightarrow H^{n-1}(RP^n) \xrightarrow{i^*} H^{n-1}(RP^{n-1}) \xrightarrow{\delta^*} H^n(RP^n, RP^{n-1}) \xrightarrow{j^*} H^n(RP^n) \xrightarrow{i^*} H^n(RP^{n-1}).$$

First of all, $H^n(RP^{n-1}; \mathbf{Z}_2) = 0$ because RP^{n-1} is only $(n - 1)$ -dimensional. Therefore, $j^* : H^n(RP^n; \mathbf{Z}_2) \rightarrow H^n(RP^{n-1}; \mathbf{Z}_2)$ is an epimorphism. Next, $H^n(RP^n; \mathbf{Z}_2)$ is cyclic of order 2 because RP^n is a compact, connected n -manifold. Since j^* is an epimorphism of a group of order 2 onto a group of order 2, it must be an isomorphism. It follows by exactness that $\delta^* : H^{n-1}(RP^{n-1}) \rightarrow H^n(RP^n, RP^{n-1})$ is the zero homomorphism. Hence, $i^* : H^{n-1}(RP^n) \rightarrow H^{n-1}(RP^{n-1})$ is an isomorphism, as was asserted.

The remainder of the inductive step is similar to that in the proof of Theorem 2.1 and may be left to the reader. The only difference is that one uses the analog for nonorientable manifolds of Theorem 5.1 rather than Theorem 5.2 of Chapter XIV.

One can express Theorem 2.1 by means of the following ring isomorphism:

$$H^*(CP^n; \mathbf{Z}) \approx \mathbf{Z}[u]/(u^{n+1});$$

in other words, the integral cohomology ring $H^*(CP^n; \mathbf{Z})$ is isomorphic to the integral polynomial ring $\mathbf{Z}[u]$ modulo the ideal generated by u^{n+1} . Similarly,

$$H^*(QP^n; \mathbf{Z}) \approx \mathbf{Z}[v]/(v^{n+1}),$$

$$H^*(RP^n; \mathbf{Z}_2) \approx \mathbf{Z}_2[w]/(w^{n+1}).$$

Rings with this type of structure are often called *truncated polynomial rings*.

We will now use this result on the structure of $H^*(RP^n; \mathbf{Z}_2)$ to prove the famous Borsuk–Ulam theorem (for a discussion of some of the interesting consequences of this theorem, the reader is referred to §V.9). Recall that a map $f : S^m \rightarrow S^n$ is called *antipode preserving* in case $f(-x) = -f(x)$ for any $x \in S^m$.

Theorem 2.4. *There does not exist any continuous antipode preserving map $f : S^n \rightarrow S^{n-1}$.*

PROOF. We will only give the proof for $n > 2$; the proof for $n \leq 2$ is contained in §V.9. The proof is by contradiction. Assume that $f : S^n \rightarrow S^{n-1}$ is an antipode preserving map. Hence, f induces a map $g : RP^n \rightarrow RP^{n-1}$ since RP^n is the quotient space obtained by identifying antipodal points of S^n . Thus, we get a commutative diagram

$$\begin{array}{ccc} S^n & \xrightarrow{f} & S^{n-1} \\ \downarrow p & & \downarrow q \\ RP^n & \xrightarrow{g} & RP^{n-1} \end{array}$$

where p and q are the projections of S^n and S^{n-1} onto their quotient spaces. Because $n > 2$, both S^n and S^{n-1} are simply connected. Thus, they are the universal covering spaces of RP^n and RP^{n-1} , respectively, and the fundamental groups, $\pi(RP^n)$ and $\pi(RP^{n-1})$, are both cyclic of order 2. The induced homomorphism

$$g_* : \pi(RP^n) \rightarrow \pi(RP^{n-1})$$

must be an isomorphism; this may be proved by an easy argument which is given in §V.9. Now consider the following commutative diagram:

$$\begin{array}{ccc} \pi(RP^n) & \xrightarrow{g_*} & \pi(RP^{n-1}) \\ \downarrow h & & \downarrow h \\ H_1(RP^n) & \xrightarrow{g_*} & H_1(RP^{n-1}) \end{array}$$

The homomorphisms denoted by h are the natural homomorphisms of the fundamental group onto the first homology group which were defined in VIII.7. Since the fundamental groups involved are abelian, these homomorphisms are both isomorphisms (cf. Theorem VIII.7.1). It follows that $g_* : H_1(RP^n) \rightarrow H_1(RP^{n-1})$ is an isomorphism.

Next, consider the following commutative diagram:

$$\begin{array}{ccc} H^1(RP^n; \mathbf{Z}_2) & \xrightarrow{\alpha} & \text{Hom}(H_1(RP^n); \mathbf{Z}_2) \\ \uparrow g^* & & \uparrow \text{Hom}(g_*, 1) \\ H^1(RP^{n-1}; \mathbf{Z}_2) & \xrightarrow{\alpha} & \text{Hom}(H_1(RP^{n-1}); \mathbf{Z}_2) \end{array}$$

The homomorphisms labeled α are those which occur in the universal coefficient theorem (§XII.4); in this case they are both isomorphism. It follows from this that

$$g^* : H^1(RP^{n-1}; \mathbf{Z}_2) \rightarrow H^1(RP^n; \mathbf{Z}_2)$$

is also an isomorphism. Let w be a generator of $H^1(RP^{n-1}; \mathbf{Z}_2)$; then $g^*(w)$ is a generator of $H^1(RP^n; \mathbf{Z}_2)$. By Theorem 2.3, $(g^*w)^n \neq 0$. However, this is a contradiction, since

$$(g^*w)^n = g^*(w^n)$$

and $w^n = 0$.

Q.E.D.

EXERCISES

- 2.1. For $k < n$, consider CP^k as the $2k$ -skeleton of CP^n . Prove that CP^k is not a retract of CP^n . Similarly, prove that for $k < n$, QP^k is not a retract of QP^n , and RP^k is not a retract of RP^n .

- 2.2. Determine the integral homology groups of RP^n by induction on n . Use the fact that RP^n is a CW-complex, as described in §IX.3, and that it is orientable for n odd, and nonorientable for n even.
- 2.3. Use the results of the preceding exercise and the universal coefficient theorem to determine the structure of the integral cohomology groups $H^k(RP^n; \mathbf{Z})$. Then determine the cup products in the integral cohomology of RP^n . (HINT: Use the homomorphism $H^k(RP^n; \mathbf{Z}) \rightarrow H^k(RP^n; \mathbf{Z}_2)$ induced by reduction mod 2 of the integers.)

§3. The Mapping Cylinder and Mapping Cone

The techniques developed in this section will be used in the next section to define certain homotopy invariants of continuous maps.

Let $f : X \rightarrow Y$ be a continuous map. The *mapping cylinder of f* , denoted by $M(f)$, is the topological space defined as follows: Assume that $X \times I$ and Y are disjoint; if they are not, take disjoint copies. Then form the quotient space of the disjoint union of $X \times I$ and Y by identifying the points $(x, 0)$ and $f(x)$ for each $x \in X$.

The mapping cylinder $M(f)$ can be visualized as a space which contains a copy of X (namely, $X \times \{1\}$), a copy of Y , and corresponding to each $x \in X$ a copy of the unit interval connecting the points x and $f(x)$. This space is topologized so that if x_1 and x_2 are points in X , that are close to each other, then the corresponding segments from x_1 to $f(x_1)$ and from x_2 to $f(x_2)$ are also close to each other.

The obvious deformation retraction of $X \times I$ onto $X \times \{0\}$ gives rise to a deformation retraction of $M(f)$ onto Y . If we denote by $i : X \rightarrow M(f)$ the inclusion map (defined by $i(x) = (x, 1)$) and by $r : M(f) \rightarrow Y$ the retraction, then the following diagram is commutative:

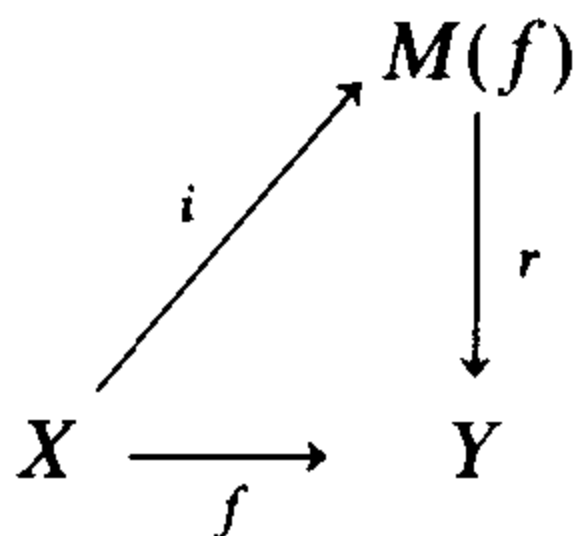

Thus, an arbitrary continuous map f is the composition of an inclusion map i and a homotopy equivalence r .

The *mapping cone of $f : X \rightarrow Y$* , denoted by $C(f)$, is the quotient space of the mapping cylinder $M(f)$ obtained by identifying the subset $X \times \{1\}$ to a single point. Alternatively, the mapping cone can be constructed as follows: let $C(X)$, called the *cone over X* , denote the quotient space of $X \times I$ obtained by identifying all of $X \times \{1\}$ to a single point. Then $C(f)$ is the quotient space of the (disjoint) union of Y and $C(X)$ obtained by identifying the point $(x, 0) \in C(X)$ with the point $f(x) \in Y$ for all $x \in X$.

Examples

3.1. If $X = S^n$, the n -sphere, then it is easily seen that $C(X)$ is homomorphic to the $(n + 1)$ -dimensional ball E^{n+1} . In this case, $C(f)$ is the same as the space $X^* = X \cup e^{n+1}$ obtained by adjoining an $(n + 1)$ -cell to the space X by means of the map f , as described in §IX.2. In particular, if K^n denotes the m -dimensional skeleton of a CW-complex, then we can regard K^{n+1} as the mapping cone of a certain map $f: X \rightarrow K^n$, where X is a disjoint union of n -spheres (assuming that the number of $(n + 1)$ -cells is finite).

One of the basic facts about the spaces $M(f)$ and $C(f)$ is that they satisfy certain naturality conditions. Let

$$\begin{array}{ccc} X & \xrightarrow{f} & Y \\ \downarrow \varphi_1 & & \downarrow \varphi_2 \\ X' & \xrightarrow{f'} & Y' \end{array}$$

be a commutative diagram of topological spaces and continuous maps. Then it is readily seen that φ_1 and φ_2 induce continuous maps of quotient spaces, $M(f) \rightarrow M(f')$ and $C(f) \rightarrow C(f')$; let us agree to denote both of these induced maps by the symbol φ . Then it follows that the following two diagrams are commutative:

$$\begin{array}{ccccc} X & \xrightarrow{i} & M(f) & \xrightarrow{r} & Y \\ \downarrow \varphi_1 & & \downarrow \varphi & & \downarrow \varphi_2 \\ X' & \xrightarrow{i'} & M(f') & \xrightarrow{r'} & Y', \end{array}$$

$$\begin{array}{ccc} Y & \xrightarrow{j} & C(f) \\ \downarrow \varphi_2 & & \downarrow \varphi \\ Y' & \xrightarrow{j'} & C(f') \end{array}$$

In the second diagram, the symbols j and j' denote obvious inclusion maps.

Lemma 3.1. *Let $p: M(f) \rightarrow C(f)$ denote the natural map which identifies the subset $X = X \times \{1\}$ of $M(f)$ to a single point P of $C(f)$. Then the induced homomorphism of relative cohomology groups*

$$p^* : H^q(C(f), P) \rightarrow H^q(M(f), X)$$

is an isomorphism for all q .

PROOF. Let \bar{X} denote the subset $X \times [\frac{1}{2}, 1]$ of $M(f)$, and let \bar{P} denote the image of \bar{X} under p . Consider the following commutative diagram:

$$\begin{array}{ccccc}
 H^q(M(f), X) & \xleftarrow{1} & H^q(M(f), \bar{X}) & \xrightarrow{3} & H^q(M(f) - X, \bar{X} - X) \\
 \uparrow p^* & & \uparrow p_1^* & & \uparrow p_2^* \\
 H^q(C(f), P) & \xleftarrow{2} & H^q(C(f), \bar{P}) & \xrightarrow{4} & H^q(C(f) - P, \bar{P} - P)
 \end{array}$$

In this diagram, the horizontal arrows denote homomorphisms induced by inclusion maps, and the vertical arrows denote homomorphisms induced by p . Arrows 1 and 2 are isomorphisms because X is a deformation retract of \bar{X} and P is a deformation retract of \bar{P} . Arrows 3 and 4 are isomorphisms by the excision property; and p_2^* is an isomorphism, because p maps $M(f) - X$ and $\bar{X} - X$ homomorphically onto $C(f) - P$ and $\bar{P} - P$, respectively. It follows that p^* is an isomorphism, as desired. Q.E.D.

Now let $k : Y \rightarrow M(f)$ denote the inclusion map; k is a homotopy equivalence because Y is a deformation retract of $M(f)$. Consider the following diagram:

$$\begin{array}{ccccccc}
 & & H^q(C(f), P) & \xrightarrow{j^*} & H^q(Y) & & \\
 & & \downarrow p^* & & \uparrow k^* \downarrow r^* & \searrow f^* & \\
 H^{q-1}(X) & \xrightarrow{\delta} & H^q(M(f), X) & \longrightarrow & H^q(M(f)) & \xrightarrow{i^*} & H^q(X)
 \end{array}$$

The bottom line is the cohomology sequence of the pair $(M(f), X)$. All the vertical arrows are isomorphisms, and k^* and r^* are inverses of each other. Finally, the diagram is readily seen to be commutative. As a consequence of these facts, we see that the following sequence of cohomology groups and homomorphisms is exact:

$$\rightarrow H^{q-1}(X) \xrightarrow{\Delta} H^q(C(f), P) \xrightarrow{j^*} H^q(Y) \xrightarrow{f^*} H^q(X) \rightarrow .$$

Here $\Delta = (p^*)^{-1}\delta$. This exact sequence will be called the *cohomology sequence of the map f* . Observe that a commutative diagram

$$\begin{array}{ccc}
 X & \xrightarrow{f} & Y \\
 \downarrow \varphi_1 & & \downarrow \varphi_2 \\
 X' & \xrightarrow{f'} & Y'
 \end{array}$$

gives rise to an induced map of the cohomology sequence of f into the cohomology sequence of f' ; that is, we get a ladderlike diagram involving the two exact sequences, and every square in the diagram is commutative.

Now let us apply these ideas to study the cohomology sequences of two maps which are homotopic. Let $f_0, f_1 : X \rightarrow Y$ be continuous maps, and let $f : X \times I \rightarrow Y$ be a homotopy between f_0 and f_1 , i.e., $f_0(x) = f(x, 0)$ and $f_1(x) = f(x, 1)$. This gives rise to the following commutative diagram:

$$\begin{array}{ccc}
 X & \xrightarrow{f_0} & Y \\
 \downarrow h_0 & & \parallel \\
 X \times I & \xrightarrow{f} & Y \\
 \uparrow h_1 & & \parallel \\
 X & \xrightarrow{f_1} & Y
 \end{array}$$

Here $h_i(x) = (x, i)$ for $i = 0$ or 1 . Corresponding to this diagram, we get a bigger diagram involving the cohomology sequences of f_0 , f , and f_1 together with homomorphisms between them. By making use of the five-lemma together with the fact that h_0 and h_1 are homotopy equivalences, we easily deduce that *the cohomology sequences of the maps f_0 and f_1 are isomorphic*. To be precise, any homotopy between f_0 and f_1 gives rise to an isomorphism between the corresponding cohomology sequences. Presumably different homotopies could give rise to different isomorphisms.

We could also word this conclusion as follows: *the cohomology sequence of a map f is a homotopy invariant of f .*

Examples

3.2. Suppose $f : X \rightarrow Y$ is a constant map. Then it is clear that Y is a retract of $C(f)$. Hence, there exists a homomorphism $r^* : H^q(Y) \rightarrow H^q(C(f))$ such that j^*r^* is the identity map of $H^q(Y)$. Moreover, r^* preserves cup products, i.e., $r^*(x \cup y) = (r^*x) \cup (r^*y)$. Because of the invariance of the cohomology sequence of f under homotopies, we can conclude that this same result is true in case $f : X \rightarrow Y$ is only assumed to be homotopic to a constant map. As a matter of fact, it is easy to prove directly that f is homotopic to a constant map if and only if Y is a retract of $C(f)$.

EXERCISES

3.1. As in the above discussion, let $f : X \times I \rightarrow Y$ be a continuous map, and let $f_0, f_1 : X \rightarrow Y$ be defined by $f_i(x, i) = f(x, i)$, $i = 0, 1$. Prove that $M(f_i)$ is a deformation retract of $M(f)$, and $C(f_i)$ is a deformation retract of $C(f)$ for $i = 0, 1$. Then deduce that the pairs $(C(f_0), Y)$ and $(C(f_1), Y)$ are of the same homotopy type.

§4. The Hopf Invariant

The Hopf invariant associates with each map $f : S^{2n-1} \rightarrow S^n$ an integer that is a homotopy invariant of f . Using it, we will be able to prove that for n even and ≥ 2 , there are infinitely many different homotopy classes of such maps.

In order to define the Hopf invariant, we will assume that the spheres S^{2n-1} and S^n are “oriented,” in the sense that definite generators $a \in H^{2n-1}(S^{2n-1}, \mathbf{Z})$ and $b \in H^n(S^n; \mathbf{Z})$ have been chosen for these infinite cyclic groups. We will also assume that $n \geq 2$. As in the preceding section, let $C(f)$ denote the mapping cone of f . It follows from the exactness of the cohomology sequence of the map f that the following two homomorphisms

$$\begin{aligned} \Delta : H^{2n-1}(S^{2n-1}) &\rightarrow H^{2n}(C(f)), \\ j^* : H^n(C(f)) &\rightarrow H^n(S^n) \end{aligned}$$

are both isomorphism. Let $a' = \Delta(a) \in H^{2n}(C(f); \mathbf{Z})$, and let $b' \in H^n(C(f), \mathbf{Z})$ be the unique element such that $j^*(b') = b$. Since $H^{2n}(C(f); \mathbf{Z})$ is infinite cyclic, there exists a unique integer $H(f)$ such that

$$b' \cup b' = H(f) \cdot a'.$$

In view of the homotopy invariance of the cohomology sequence of f , the integer $H(f)$ depends only on the homotopy class of f .

We will now list some of the principal properties of the Hopf invariant:

(1) If n is odd and $n > 1$ then $H(f) = 0$ for any map $f : S^{2n-1} \rightarrow S^n$. This follows from the anticommutative law for cup products. As a consequence, the Hopf invariant is useless in this case.

(2) If $n = 2, 4,$ or 8 , there exist maps $f : S^{2n-1} \rightarrow S^n$ such that $H(f) = \pm 1$. For $n = 2$ we may choose f such that $C(f) = CP^2$, the complex projective plane; whereas for $n = 4$, we may choose f such that $C(f) = QP^2$. The case $n = 8$ is more complicated; in essence, we must choose f so that $C(f)$ is the so-called *Cayley projective plane*. An explicit description of such a map f is given by Steenrod [5, pp. 109–110]. A complete discussion of the Cayley projective plane is given by H. Freudenthal [4].

(3) For any even integer $n \geq 2$, there exist maps f such that $H(f) = \pm 2$. To prove this, recall that S^n may be considered as a CW-complex with a single vertex, e^0 , a single n -cell e^n , and no cells of any other dimension. Hence $S^n \times S^n$ may be represented as a CW-complex with one vertex, $e^0 \times e^0$, two n -cells, $e^0 \times e^n$ and $e^n \times e^0$, and one $2n$ -cell, $e^n \times e^n$. The n -skeleton of this CW-complex is the subspace

$$S^n \vee S^n = (S^n \times e^0) \cup (e^0 \times S^n)$$

of $S^n \times S^n$. Let $g : S^{2n-1} \rightarrow S^n \vee S^n$ denote the attaching map for the single $2n$ -cell of this CW-complex, and let $h : S^n \vee S^n \rightarrow S^n$ be defined by $h(x, e^0) = h(e^0, x) = x$ for $x \in S^n$ (h is sometimes called the *folding map*). We assert that if we define

$$f = hg : S^{2n-1} \rightarrow S^n,$$

then (for n even), $H(f) = \pm 2$. To prove this assertion, consider the following commutative diagram:

$$\begin{array}{ccccc}
 S^{2n-1} & \xrightarrow{g} & S^n \vee S^n & \xrightarrow{j_1} & C(g) \\
 \parallel & & \downarrow h & & \downarrow h' \\
 S^{2n-1} & \xrightarrow{f} & S^n & \xrightarrow{j_2} & C(f)
 \end{array}$$

Here h' is induced by h . By definition, $C(g) = S^n \times S^n$. Let b denote the chosen generator of $H^n(S^n; \mathbf{Z})$. Then $\{b \times 1, 1 \times b\}$ is a basis for $H^n(S^n \times S^n)$ and $(b \times 1) \cup (1 \times b) = b \times b$ is a generator of $H^{2n}(S^n \times S^n)$ (cf. §XIII.11). Now, consider the following commutative diagram:

$$\begin{array}{ccc}
 H^n(S^n \vee S^n) & \xleftarrow{j_1^*} & H^n(S^n \times S^n) \\
 \uparrow h^* & & \uparrow h^* \\
 H^n(S^n) & \xleftarrow{j_2^*} & H^n(C(f))
 \end{array}$$

Both j_1^* and j_2^* are isomorphisms, and $j_2^*(b') = b$. We leave it to the reader to convince himself that

$$h'^*(b') = (b \times 1) + (1 \times b).$$

We also have the following commutative diagram:

$$\begin{array}{ccc}
 H^{2n}(S^n \times S^n) & & \\
 \uparrow h^* & \swarrow \Delta_1 & \\
 H^{2n}(C(f)) & & H^{2n-1}(S^{2n-1}) \\
 & \searrow \Delta_2 &
 \end{array}$$

Both Δ_1 and Δ_2 are isomorphisms, hence h^* is an isomorphism. Let us assume that the generator $a \in H^{2n-1}(S^{2n-1})$ is chosen so that $\Delta_1(a) = b \times b$; hence $h^*(a') = b \times b$. To prove our assertion, apply the homomorphism h^* to the equation

$$b' \cup b' = H(f) \cdot a'.$$

The result is

$$(b \times 1 + 1 \times b) \cup (b \times 1 + 1 \times b) = H(f)(b \times b);$$

hence, $H(f) = 2$. If we had used the orientation of S^{2n-1} determined by the generator $-a$, we would have obtained $H(f) = -2$.

(4) Let $f: S^{2n-1} \rightarrow S^n$, be a continuous map, and $h: S^n \rightarrow S^n$ a map of degree k [i.e., $h^*(b) = kb$]. Then

$$H(hf) = k^2 H(f).$$

(5) Let $h: S^{2n-1} \rightarrow S^{2n-1}$ be a map of degree k [i.e., $h^*(a) = ka$] and $f: S^{2n-1} \rightarrow S^n$ a continuous map. Then

$$H(fh) = k \cdot H(f).$$

The proof of assertions (4) and (5) are left to the reader as exercises.

Remark: Assume that n is even and ≥ 2 . It follows from the preceding paragraphs that given any integer $2m$, there exists a map $f : S^{2n-1} \rightarrow S^n$ such that $H(f) = 2m$. It is known that $H(f)$ is of necessity an even integer, except when $n = 2, 4$, or 8 . This was proved by José Adem [2] for $n \neq 2^k$ and by J. F. Adams [1] for $n = 2^k, k > 3$.

It is also known that two maps $f_0, f_1 : S^3 \rightarrow S^2$ are homotopic if and only if $H(f_0) = H(f_1)$. In general, such a statement is not true for maps of S^{2n-1} into $S^n, n > 2$. However, it is known that there are only a finite number of homotopy classes of such maps having a given integer as Hopf invariant.

EXERCISES

4.1. Given any space X , define the *suspension of X* , denoted $S(X)$, to be the quotient space of $X \times I$ obtained by identifying each of the subsets $X \times 0$ and $X \times 1$ to a point; it is a sort of “double cone” over X . Similarly, if $f : X \rightarrow Y$ is a continuous map, define $S(f) : S(X) \rightarrow S(Y)$ to be the map induced on quotient spaces by the map of $X \times I$ into $Y \times I$ which sends (x, t) to (fx, t) .

- (a) If $X = S^n$, prove that $S(X)$ is homeomorphic to S^{n+1} .
- (b) What is the relation between the homology groups of X and those of $S(X)$?
- (c) If $u \in H^p(S(X))$ and $v \in H^q(S(X))$, where $p > 0$ and $q > 0$, prove that $u \cup v = 0$.
- (d) If $f_0, f_1 : X \rightarrow Y$, and f_0 is homotopic to f_1 , prove that $S(f_0)$ is homotopic to $S(f_1)$.
- (e) Let $f : X \rightarrow Y$; we would like to prove that $C(Sf) = S(Cf)$. Unfortunately, this is not quite true. Prove that there is a natural map $S(Cf) \rightarrow C(Sf)$ which induces isomorphisms of homology and cohomology groups.
- (f) Let $f : S^{2n-2} \rightarrow S^{n-1}$ be a continuous map; in view of (a), the Hopf invariant $H(Sf)$ is defined. Prove that $H(Sf) = 0$. [REMARK: The converse of this last statement is true “up to homotopy.” To be more explicit, let $g : S^{2n-1} \rightarrow S^n$ be a map such that $H(g) = 0$. Then there exists a map $f : S^{2n-2} \rightarrow S^{n-1}$ such that g is homotopic to $S(f)$; see G. W. Whitehead [6].]

NOTES

The Hopf Invariant for the case of a map from S^3 to S^2 was first introduced by H. Hopf in 1931 in a paper in volume 104 of *Mathematische Annalen*. This paper was quite surprising in its day, because it gave the first example of a continuous map of a sphere to a sphere of lower dimension which was not homotopic to a constant map. In 1935 in a paper in volume 25 of *Fundamenta Mathematica*, Hopf considered the general case of a mapping from S^{2n-1} to S^n . In these papers, Hopf used intersection theory to define his invariant (see the Notes to the preceding chapter). A more modern account of the Hopf invariant using cup products and the mapping cylinder was given by N. E. Steenrod in 1949 in volume 50 of the *Annals of Mathematics*. The Hopf invariant has been extensively generalized by G. W. Whitehead and others; see [6, Chapter XI].

References

1. J. F. Adams, On the nonexistence of elements of Hopf invariant one, *Ann. Math.* **72** (1960), 20–104.
2. J. Adem, The iteration of Steenrod squares in algebraic topology, *Proc. Nat. Acad. Sci.* **38** (1952), 720–726.
3. N. Bourbaki, *General Topology, Part 2*, Addison-Wesley, Reading, Mass., 1966.
4. H. Freudenthal, *Oktaven, Ausnahme-gruppen, und Oktavengeometrie* (mimeographed), Utrecht, 1951, revised ed., 1960.
5. N. E. Steenrod, *The Topology of Fibre Bundles*, Princeton University Press, Princeton, N.J., 1951.
6. G. W. Whitehead, *Elements of Homotopy Theory*, Springer-Verlag, New York, 1978.

APPENDIX A

A Proof of De Rham's Theorem

§1. Introduction

In Chapter VI we mentioned that some of the motivating ideas for the development of homology theory in the nineteenth century arose in connection with such topics as Stokes's theorem, Green's theorem, Gauss's divergence theorem, and the Cauchy integral theorem. De Rham's theorem may be looked on as the modern culmination of this particular line of thought. It relates the homology and cohomology of a differentiable manifold to the exterior differential forms on the manifold. Exterior differential forms are objects which can serve as integrands of line integrals, surface integrals, etc., such as occur in the statement of the classical Green's theorem and Stokes's theorem. De Rham's theorem is of obvious importance because it is a connecting link between analysis on manifolds and the topological properties of manifolds.

In this appendix we will assume that the reader is familiar with the basic properties of differentiable manifolds, differential forms on manifolds, and the integration of differential forms over (differentiable) singular cubes. These topics are explained in many current textbooks, and there would be little point in our repeating such an exposition here. As examples of such texts, we list the following: M. Spivak [6], Flanders [3], Warner [9], and Whitney [10].

The first part of this chapter is devoted to using differentiable singular cubes to define the homology and cohomology groups of a differentiable manifold. We prove that in studying the homology and cohomology groups of such a manifold, it suffices to consider only *differentiable* singular cubes; the non-differentiable ones can be ignored.

Next, we introduce what may be called the *De Rham cochain complex* of a differentiable manifold. This cochain complex consists of the exterior differ-

ential forms, with the exterior derivative serving as the coboundary operator. There is a natural homomorphism from this De Rham complex to the cochain complex (with coefficient group \mathbf{R} , the real numbers) based on differentiable singular cubes. This homomorphism is defined on any exterior differential form of degree p by integrating that form over differentiable singular p -cubes. The general form of Stokes's theorem is precisely the assertion that this natural homomorphism is a cochain map. De Rham's theorem asserts that this natural cochain map induces an isomorphism on cohomology.

The proof we give of De Rham's theorem is modeled on Milnor's proof of the Poincaré duality theorem in Chapter XIV. The reader who has worked through that proof should have no trouble grasping the structure of our proof of De Rham's theorem. Curtis and Dugundji [11] have also given a proof of De Rham's theorem along somewhat similar lines.

§2. Differentiable Singular Chains

Let M be an n -dimensional differentiable manifold of class C^∞ (we assume the reader is familiar with this concept). In order to define a differentiable singular cube, we must make use of the fact that the standard unit p -cube,

$$I^p = \{(x_1, \dots, x_p) \in \mathbf{R}^p \mid 0 \leq x_i \leq 1, i = 1, 2, \dots, p\}$$

is a subset of Euclidean space \mathbf{R}^p . For $p > 0$, a singular p -cube $T : I^p \rightarrow M$ will be called *differentiable* if there exists an open neighborhood U of I^p in \mathbf{R}^p and an extension $T' : U \rightarrow M$ of T such that T' is differentiable (of class C^∞). We complete this definition by defining any singular 0-cube to be differentiable.

Remark: If a singular p -cube $T : I^p \rightarrow M$ is differentiable, there will, in general, be many different choices for the open neighborhood U and the extension $T' : U \rightarrow M$.

We now introduce the following notation:

$$Q_p^S(M) = \text{subgroup of } Q_p(M) \text{ generated by the} \\ \text{differentiable singular } p\text{-cubes,}$$

$$D_p^S(M) = D_p(M) \cap Q_p^S(M),$$

$$C_p^S(M) = Q_p^S(M)/D_p^S(M).$$

The superscript S in the above notation is intended to suggest the word "smooth." We will refer to $C_p^S(M)$ as the group of differentiable or smooth p -chains of M . Note that $C_0^S(M) = Q_0^S(M) = Q_0(M) = C_0(M)$.

Next, observe that if $T : I^p \rightarrow M$ is a differentiable singular p -cube, then the faces $A_i T$ and $B_i T$, $1 \leq i \leq p$, are all obviously differentiable singular $(p - 1)$ -cubes. It follows that $\partial_p(T) \in Q_{p-1}^S(M)$. Thus, $Q^S(M) = \{Q_p^S(M), \partial_p\}$ is a subcomplex of $Q(M)$, and $C^S(M) = \{C_p^S(M)\}$ is a subcomplex of $C(M)$. We will

also introduce the following notation: for any abelian group G ,

$$C^S(M; G) = C^S(M) \otimes G,$$

$$C_S^*(M; G) = \text{Hom}(C^S(M), G),$$

$$H_p^S(M; G) = H_p(C^S(M; G)),$$

$$H_S^p(M; G) = H^p(C_S^*(M; G)).$$

We can now state the main theorem of this section:

Theorem 2.1. *Let M be a differentiable manifold. The inclusion map of chain complexes,*

$$C^S(M) \rightarrow C(M),$$

induces an isomorphism of homology groups,

$$H_p^S(M) \approx H_p(M).$$

Corollary 2.2. *For any abelian group G , we have the following isomorphisms of homology and cohomology groups:*

$$H_p^S(M; G) \approx H_p(M; G),$$

$$H_S^p(M; G) \approx H^p(M; G).$$

The corollary follows from the theorem by use of standard techniques (cf. Theorem X.2.8). Before we can prove the theorem, it is necessary to discuss to what extent the methods and results of Chapters VII and VIII on homology theory carry over to the homology groups $H_p^S(M; G)$ for any differentiable manifold M . We will now do this in a brief but systematic fashion.

(a) Let M_1 and M_2 be differentiable manifolds, and let $f: M_1 \rightarrow M_2$ be a differentiable map of class C^∞ . If $T: I^p \rightarrow M_1$ is a differentiable singular p cube, in M_1 , then $fT: I^p \rightarrow M_2$ is also differentiable. Hence, we get an induced chain map

$$f_\# : C^S(M_1) \rightarrow C^S(M_2)$$

with all the usual properties.

(b) Two differentiable maps $f_0, f_1: M_1 \rightarrow M_2$ will be called *differentially homotopic* if there exists a map $f: I \times M_1 \rightarrow M_2$ such that $f_0(x) = f(0, x)$ and $f_1(x) = f(1, x)$ for any $x \in M_1$, and in addition, there exists an open neighborhood U of $I \times M_1$ in $\mathbf{R} \times M_1$ and a map $f': U \rightarrow M_2$ which is an extension of f , and is differentiable of class C^∞ . The technique of §VII.4 can now be applied *verbatim* to prove that the induced chain maps $f_{0\#}, f_{1\#}: C^S(M_1) \rightarrow C^S(M_2)$ are chain homotopic. This has all the usual consequences; in particular, the induced homomorphisms on homology and cohomology groups are the same.

(c) An open, convex subset of \mathbf{R}^n is *differentially contractible* to a point; in fact, the standard formulas for proving that such a subset is contractible are

differentiable homotopies in the sense of the preceding definition. From this it follows that if U is an open, convex subset of \mathbf{R}^n , then

$$H_p^S(U; G) = \begin{cases} G & \text{for } p = 0 \\ 0 & \text{for } p \neq 0, \end{cases}$$

with similar formulas for $H_p^S(U; G)$.

(d) Let M be a differentiable manifold, and let A be a subspace of M which is a differentiable submanifold. For example, A could be an arbitrary open subset of M , or A could be a closed submanifold of M . Then we can consider $C^S(A)$ as a subcomplex of $C^S(M)$; hence, we can consider the quotient complex $C^S(M)/C^S(A) = C^S(M, A)$ and we obtain exact homology and cohomology sequences for the pair (M, A) using differentiable singular cubes.

(e) If $T: I^n \rightarrow M$ is a differentiable singular cube, the subdivision of T , $\text{Sd}_n(T)$ as defined in §VII.7, is readily seen to be a linear combination of differentiable singular cubes. Hence, the subdivision operator defines a chain map

$$\text{sd} : C^S(M) \rightarrow C^S(M)$$

just as in §VII.7. Unfortunately, the chain homotopy $\varphi_n : C_n(M) \rightarrow C_{n+1}(M)$ defined in §VII.7 does *not* map $C_n^S(M)$ into $C_{n+1}^S(M)$. This is because the function $\eta_1 : I^2 \rightarrow [\frac{1}{2}, 1]$ is not differentiable (the function $\eta_0 : I^2 \rightarrow I$ is differentiable). However, it is not difficult to get around this obstacle. Consider the real-valued function η'_1 defined by

$$\eta'_1(x_1, x_2) = \frac{1 + x_1 - x_1x_2}{2 - x_2}.$$

It is readily verified that η'_1 maps I^2 into the interval $[\frac{1}{2}, 1]$, and that η_1 and η'_1 are equal along the boundary of the square I^2 . Obviously, η'_1 is differentiable in a neighborhood of I^2 . Thus, if we substitute η'_1 for η_1 in the formula for $G_e(T)$ in §VII.7, then $G_e(T)$ will be a linear combination of differentiable singular cubes whenever T is a differentiable singular cube. Moreover, the operator G_e will continue to satisfy identities (f.1) to (f.4) of §VII.7. Thus, we can define a chain homotopy $\varphi_n : C_n^S(M) \rightarrow C_{n+1}^S(M)$ using the modified definition of G_e . From this point on, everything proceeds exactly as in §VII.7. The net result is that we can prove an analog of Theorem VII.6.3 for singular homology based on differentiable singular cubes, and the excision property (Theorem VII.6.2) holds for this kind of homology theory.

(f) Suppose that the differentiable manifold M is the union of two open subsets,

$$M = U \cup V.$$

Then we can obtain an exact Mayer–Vietoris sequence for this situation by the method described in §VIII.5.

(g) Finally, we note that an analog of Proposition VIII.6.1 must hold for homology groups based on differentiable singular cubes; this is practically obvious.

With these preparations out of the way, we can now prove Theorem 2.1. The pattern of proof is similar to Milnor's proof of the Poincaré duality theorem in §4 of Chapter XIV, only this proof is much easier. We prove the theorem for the easiest cases first, and then proceed to successively more general cases.

Case 1: M is a single point. This case is completely trivial.

Case 2: M is an open convex subset of Euclidean n -space, \mathbf{R}^n . This follows easily from case 1, since M is differentiably contractible to a point in this case.

Case 3: $M = U \cup V$, where U and V are open subsets of M , and the theorem is assumed to be true for U , V , and $U \cap V$. This case is proved by use of the Mayer–Vietoris sequence and the five-lemma.

Case 4: M is the union of a nested family of open sets, and the theorem is assumed to be true for each set of the family. Then the theorem is true for M . The proof is by an easy argument using direct limits, and Proposition VIII.6.1.

Case 5: M is an open subset of \mathbf{R}^n . Every open subset of \mathbf{R}^n is a countable union of convex open subsets,

$$M = \bigcup_{i=1}^{\infty} U_i.$$

For each U_i the theorem is true by case 2. For any finite union, $\bigcup_{i=1}^n U_i$ the theorem is true by induction on n , using case 3 and the basic properties of convex sets. Then one uses case 4 to prove the theorem for M .

Case 6: The general case. Any differentiable manifold can be covered by coordinate neighborhoods, each of which is diffeomorphic to an open subset of Euclidean space. Using case 4, case 5, and Zorn's lemma, we see that there must exist a nonempty open subset $U \subset M$ such that the theorem is true for U , and U is maximal among all open sets for which the theorem is true. If $U \neq M$, then we can find a coordinate neighborhood V such that V is not contained in U . By case 3, the theorem is true for $U \cup V$, contradicting the maximality of U . Hence $U = M$, and the proof is complete.

§3. Statement and Proof of De Rham's Theorem

For any differentiable manifold M , we will denote by $D^q(M)$ the set of C^∞ differential forms on M of degree q . $D^q(M)$ is a vector space over the field of real numbers. As usual, $d : D^q(M) \rightarrow D^{q+1}(M)$ will denote the exterior differential. Since $d^2 = 0$,

$$D^*(M) = \{D^q(M), d\}$$

is a cochain complex, which will be referred to as the *De Rham complex* of M .

If $f: M_1 \rightarrow M_2$ is a differentiable map (of class C^∞), then there is defined in a well-known way a homomorphism $f^*: D^q(M_2) \rightarrow D^q(M_1)$. The homomorphism f^* commutes with the exterior differential d , and hence it is a cochain map of $D^*(M_2)$ into $D^*(M_1)$.

Given any differentiable singular n -cube $T: I^n \rightarrow M$, and any differential form $\omega \in D^n(M)$, there is defined the integral of ω over T , denoted by

$$\int_T \omega$$

(cf. Spivak [6, p. 100ff]). The basic idea of the definition is quite simple: $T^*(\omega)$ is a differential form of degree n on the cube I^n ; hence, it can be written

$$T^*(\omega) = f dx_1 dx_2 \cdots dx_n$$

in terms of the usual coordinate system (x_1, x_2, \dots, x_n) in I^n . Then $\int_T \omega$ is defined to be the n -fold integral of the C^∞ real-valued function f over the cube I^n . Actually, the preceding definition only makes sense if $n > 0$; in case $n = 0$, ω is a real-valued function, and $I^n = I^0$ is a point. In this case $\int_T \omega$ is defined to be the value of the function ω at the point $T(I^0) \in M$.

More generally, if

$$u = \sum a_i T_i$$

is a linear combination of differentiable singular n -cubes, then we define

$$\int_u \omega = \sum a_i \int_{T_i} \omega.$$

With this notation, we can write the generalized Stokes's theorem as follows: For any $u \in Q_n^S(M)$ and any $\omega \in D^{n-1}(M)$,

$$\int_u d\omega = \int_{\partial u} \omega.$$

For the proof, see Spivak [6, p. 102–104].

At this stage, we should mention three formal properties of the integral of a differential form over a singular chain. The proofs are more or less obvious

(a) The integral $\int_u \omega$ is a bilinear function

$$Q_n^S(M) \times D^n(M) \rightarrow \mathbf{R}.$$

In other words, for each u it is a linear function of ω , and for each ω it is a linear function of u .

(b) Let $f: M_1 \rightarrow M_2$ be a differentiable map, $u \in Q_n^S(M_1)$, and $\omega \in D^n(M_2)$. Then

$$\int_u f^*(\omega) = \int_{f_*(u)} \omega.$$

(c) If u is a *degenerate* singular n -chain, i.e., $u \in D_n^S(M)$, then

$$\int_u \omega = 0$$

for any differential form ω of degree n .

In view of Property (a), we can define a homomorphism

$$\varphi : D^n(M) \rightarrow \text{Hom}(Q_n^S(S), \mathbf{R})$$

by the formula

$$\langle \varphi\omega, u \rangle = \int_u \omega$$

for any $\omega \in D^n(M)$ and any $u \in Q_n^S(M)$. The generalized Stokes's theorem now translates into the assertion that φ is a cochain map

$$D^*(M) \rightarrow \text{Hom}(Q^S(M), \mathbf{R})$$

and property (c) translates into the assertion that the image of φ is contained in the subcomplex $\text{Hom}(C^S(M), \mathbf{R}) = C_S^*(M; \mathbf{R})$; thus, we can (and will) look on φ as a cochain map

$$\varphi : D^*(M) \rightarrow C_S^*(M; \mathbf{R}).$$

Finally, property (b) is equivalent to the assertion that the cochain map φ is natural via a vis differentiable maps of manifolds.

Theorem 3.1. (De Rham's theorem). *For any paracompact differentiable manifold M , the cochain map φ induces a natural isomorphism $\varphi^* : H^n(D^*(M)) \approx H_S^n(M; \mathbf{R})$ of cohomology groups.*

If we combine this result with Corollary 2.2, we see that $H^n(D^*(M))$ is naturally isomorphic to $H^n(M; \mathbf{R})$ for any paracompact differentiable manifold M .

PROOF OF DE RHAM'S THEOREM. The proof proceeds according to the same basic pattern as Milnor's proof of the Poincaré duality theorem in Chapter XIV.

Case 1: M is an open, convex subset of Euclidean n -space, \mathbf{R}^n . In this case, we know from the results of §2 that

$$H_n^S(M; \mathbf{R}) = \begin{cases} \mathbf{R} & \text{if } n = 0 \\ \mathbf{0} & \text{if } n \neq 0. \end{cases}$$

Similarly,

$$H^n(D^*(M)) = \begin{cases} \mathbf{R} & \text{if } n = 0 \\ \mathbf{0} & \text{if } n \neq 0. \end{cases}$$

This is essentially the content of the so-called Poincaré lemma (see Spivak, [6, p. 94]). Thus, to prove the theorem in this case, we only have to worry about what happens in degree 0. This is made easier by the fact that in degree 0, every cohomology class contains exactly one cocycle. The details of the proof are simple, and may be left to the reader.

Case 2: M is the union of two open subsets, U and V , and De Rham's theorem is assumed to hold for U , V , and $U \cap V$. Then De Rham's theorem holds for M .

To prove the theorem in this case we use Mayer–Vietoris sequences. We already have a Mayer–Vietoris sequence for cohomology based on differentiable singular cubes; we will now derive such a sequence for the De Rham cohomology. Let $i: U \cap V \rightarrow U$, $j: U \cap V \rightarrow V$, $k: U \rightarrow M$, and $l: V \rightarrow M$ denote inclusion maps. Define cochain maps

$$\alpha: D^*(M) \rightarrow C^*(U) \oplus D^*(V),$$

$$\beta: D^*(U) \oplus D^*(V) \rightarrow D^*(U \cup V)$$

by

$$\alpha(\omega) = (k^*\omega, l^*\omega),$$

$$\beta(\omega_1, \omega_2) = i^*(\omega_1) - j^*(\omega_2).$$

We assert that the following sequence

$$0 \rightarrow D^*(M) \xrightarrow{\alpha} D^*(U) \oplus D^*(V) \xrightarrow{\beta} D^*(U \cap V) \rightarrow 0 \quad (\text{A.3.1})$$

is exact. The only part of this assertion which is not easy to prove is the fact that β is an epimorphism. This may be proved as follows. Let $\{g, h\}$ be a C^∞ partition of unity subordinate to the open covering $\{U, V\}$ of M . This means that g and h are C^∞ real-valued functions defined on M such that the following conditions hold: $g + h = 1$, $0 \leq g(x) \leq 1$ and $0 \leq h(x) \leq 1$ for any $x \in M$, the closure of the set $\{x \in M | g(x) \neq 0\}$ is contained in U , and the closure of the set $\{x \in M | h(x) \neq 0\}$ is contained in V . The hypothesis that M is paracompact implies the existence of such a partition of unity. The proof is given in many textbooks, e.g., De Rham [2, p. 4], Sternberg [8, Chapter II, §4], Auslander and Mackenzie [1, §5–6]. Now let ω be a differential form on $U \cap V$. Then $g\omega$ can be extended to C^∞ differential form ω_U on U by defining $\omega_U(x) = 0$ at any point $x \in U - (U \cap V)$. Similarly, $h\omega$ can be extended to a C^∞ differential form ω_V on V by defining $\omega_V(y) = 0$ at any point $y \in V - (U \cap V)$. Then it is easily verified that

$$\beta(\omega_U - \omega_V) = \omega$$

as desired.

On passage to cohomology, the short exact sequence (A.3.1) gives rise to a Mayer–Vietoris sequence for De Rham cohomology.

Similarly, the Mayer–Vietoris sequence for cohomology based on differentiable singular cubes is a consequence of the following short exact sequence

of cochain complexes (cf. §VIII.5):

$$0 \rightarrow C_S^*(M, \mathcal{U}) \xrightarrow{\alpha'} C_S^*(U) \oplus C_S^*(V) \xrightarrow{\beta'} C_S^*(U \cap V) \rightarrow 0. \quad (\text{A.3.2})$$

Here $\mathcal{U} = \{U, V\}$ is an open covering of M , and the definition of the cochain maps α' and β' is similar to that of α and β above.

Finally, we may put these two short exact sequences together in a commutative diagram as follows:

$$\begin{array}{ccccccc}
 0 & \longrightarrow & D^*(M) & \xrightarrow{\alpha} & D^*(U) \oplus D^*(V) & \xrightarrow{\beta} & D^*(U \cap V) \longrightarrow 0 \\
 & & \downarrow \varphi & & \downarrow \varphi & & \downarrow \varphi \\
 & & C_S^*(M) & & & & \\
 & & \downarrow a & & & & \\
 0 & \longrightarrow & C_S^*(M, \mathcal{U}) & \xrightarrow{\alpha'} & C_S^*(U) \oplus C_S^*(V) & \xrightarrow{\beta'} & C_S^*(U \cap V) \longrightarrow 0
 \end{array}$$

The cochain map labeled a is induced by the inclusion of the subcomplex $C^S(M, \mathcal{U})$ in $C^S(M)$; it induces an isomorphism on cohomology. Clearly, each square of this diagram is commutative. On passage to cohomology we obtain the diagram we need to prove this case of De Rham's theorem.

Case 3: $M = \bigcup_{i=1}^{\infty} U_i$, where $U_1 \subset U_2 \subset \dots \subset U_i \subset U_{i+1} \subset \dots$ is a nested sequence of open sets, and for each i , \bar{U}_i is compact. It is assumed that De Rham's theorem holds for each U_i ; we will show that it holds for M . To carry out the proof in this case, we need to make use of inverse limits. The reader can find all the required material on inverse limits in the appendix, pp. 381–410 of Massey [5].

First, for each index i there is a cochain map $D^*(M) \rightarrow D^*(U_i)$ induced by inclusion of U_i in M . This is a compatible family of maps, and $D^*(M)$ is the inverse limit of the inverse system of cochain complexes $\{D^*(U_i)\}$ (this is practically obvious from the definitions of inverse limit and differential form). Moreover, for each q , the inverse sequence or tower $\{D^q(U_i)\}$ satisfies the Mittag-Leffler condition; this is an easy consequence of the assumption that each \bar{U}_i is compact. It follows that the first derived functor

$$\lim^1 D^q(U_i) = 0$$

for all q . Hence, we can apply Theorem A.19 on pp. 407–408 of Massey [5] to conclude that there exists a natural short exact sequence

$$0 \rightarrow \lim^1 H^{q-1}(D^*(U_i)) \rightarrow H^q(D^*(M)) \rightarrow \lim \text{inv } H^q(D^*(U_i)) \rightarrow 0. \quad (\text{A.3.3})$$

Next, we will prove similar facts about the cochain complexes $C_S^*(U_i; \mathbf{R})$ and $C^*(M; \mathbf{R})$. We know that the chain complex $C^S(M)$ is the direct limit of the chain complexes $C^S(U_i)$,

$$C^S(M) = \text{dir lim } C^S(U_i).$$

Apply the functor $\text{Hom}(\ , \mathbf{R})$, we see that

$$\begin{aligned} C_S^*(M; \mathbf{R}) &= \text{Hom}(C^S(M); \mathbf{R}) \\ &= \text{inv lim Hom}(C^S(U_i); \mathbf{R}) \\ &= \text{inv lim } C_S^*(U_i; \mathbf{R}); \end{aligned}$$

(compare Exercise 2 on p. 297 of Massey [5]). Moreover, for each index i , the homomorphism

$$C_S^*(U_{i+1}; \mathbf{R}) \rightarrow C_S^*(U_i; \mathbf{R})$$

is obviously an epimorphism. Therefore, the Mittag–Leffler condition holds for the inverse sequence of cochain complexes $\{C_S^*(U_i; \mathbf{R})\}$. Applying Theorem A.19 of Massey [5] to this situation, we obtain the following natural short exact sequence:

$$0 \rightarrow \lim^1 H_S^{q-1}(U_i; \mathbf{R}) \rightarrow H_S^q(M; \mathbf{R}) \rightarrow \lim \text{inv } H_S^q(U_i; \mathbf{R}) \rightarrow 0. \quad (\text{A.3.4})$$

We may now apply the cochain map φ to obtain a homomorphism from Sequence (A.3.3) into the Sequence (A.3.4). This homomorphism enables one to easily complete the proof in this case.

Case 4: M is an open subset of Euclidean space. Every such M is obviously the union of a countable family of convex open subsets $\{U_i\}$ having the property that each \bar{U}_i is compact and $\bar{U}_i \subset M$. Then one proves that De Rham's theorem holds true for finite unions

$$\bigcup_{i=1}^n U_i$$

by an induction on n , using case 2 and the basic properties of convex sets. Next one passes to the limit as $n \rightarrow \infty$, using case 3.

Case 5: M is a connected paracompact manifold. It is known that any connected paracompact manifold has a countable basis of open sets (for a thorough discussion of the topology of paracompact manifolds, see the appendix to Volume I of Spivak [7]). It follows that M is the union of a countable family of open sets $\{U_i\}$ such that each U_i is a coordinate neighborhood (and hence diffeomorphic to an open subset of Euclidean space) and \bar{U}_i is compact. Let $V_n = U_1 \cup U_2 \cup \cdots \cup U_n$. Using case 2 and 4, we can prove by induction on n that De Rham's theorem is true for each V_n . Note that \bar{V}_n is compact, and $M = \bigcup_{n=1}^{\infty} V_n$. Hence, it follows from case 3 that De Rham's theorem holds for M .

Case 6: The general case. By case 5, De Rham's theorem is true for each component of M . It follows easily that it is true for M .

This completes the proof of De Rham's theorem. We conclude by pointing out two directions in which De Rham's theorem can be extended:

(a) One of the basic operations on differential forms is the product: if ω and θ are differential forms of degree p and q , respectively, then their product, $\omega \wedge \theta$, is a differential form of degree $p + q$. Moreover, the differential of such

a product is given by the standard formula:

$$d(\omega \wedge \theta) = (d\omega) \wedge \theta + (-1)^p \omega \wedge (d\theta).$$

It follows that this product in the De Rham complex $D^*(M)$ gives rise to a product in $H^*(M)$, just as the cup product in the cochain complex $C_S^*(M; \mathbf{R})$ gives rise to cup products in $H_S^*(M, \mathbf{R})$. It can then be proved that the De Rham isomorphism.

$$\varphi^* : H^*(D^*(M)) \rightarrow H_S^*(M; \mathbf{R})$$

preserves products. However, the proof is of necessity rather roundabout, since the cochain map $\varphi : D^*(M) \rightarrow C_S^*(M; \mathbf{R})$ definitely is *not* a ring homomorphism. For a discussion and proof of these matters in a context somewhat similar to that of this appendix, see V. Guillemin [4]. Guillemin's paper makes heavy use of the technique of acyclic models.

(b) Given any differential form ω on M , we define the *support* of ω to be the closure of the set $\{x \in M \mid \omega(x) \neq 0\}$. With this definition, it is readily seen that the set of all differential forms of degree p which have compact support is a vector subspace of $D^p(M)$, which we will denote by $D_c^p(M)$. Moreover, if the support of ω is compact, then so is the support of $d(\omega)$. Hence, $D_c^*(M) = \{D_c^p(M), d\}$ is a cochain subcomplex of $D^*(M)$.

Now consider the cochain map $\varphi : D^*(M) \rightarrow C_S^*(M; \mathbf{R})$. It is clear that if ω is a differential form with compact support, then $\varphi(\omega)$ is a cochain with compact support in accordance with the definition in §XIV.3 (be to precise, that definition has to be modified slightly because we are using cochains which are defined only on *differentiable* singular cubes). It can now be proved that φ induces an isomorphism of $H^q(D_c^*(M))$ onto the q -dimensional cohomology group of M with compact supports and real coefficients. The details are too lengthy to be included in this appendix. Such a theorem is usually proven in books on sheaf theory.

NOTE

Georges De Rham's famous theorem was contained in his thesis, which was published in 1931 in volume 10 of the *Journal de Mathématiques Pures et Appliquées*. At that time cohomology groups had not yet been introduced, so of course he did not state his theorem in the way that is customary today. Instead, he gave a logically equivalent statement involving Betti numbers, integration of closed differential forms over cycles, etc.

References

1. L. Auslander and R. Mackenzie, *Introduction to Differentiable Manifolds*, McGraw-Hill, New York, 1963.
2. G. De Rham, *Variétés Différentiable: Formes, Courants, Formes Harmoniques*. Hermann et Cie., Paris, 1955.

3. H. Flanders, *Differential Forms with Applications to the Physical Sciences*, Academic Press, New York, 1963 (especially Chapters I, II, III, and V).
4. V. Guillemin, On the multiplicative structure of De Rham theory. *J. Differential Geometry* **11** (1976), 309–314.
5. W. S. Massey, *Homology and Cohomology Theory: An Approach Based on Alexander–Spanier Cochains*, Marcel Dekker, Inc., New York, 1978.
6. M. Spivak, *Calculus on Manifolds*, W. A. Benjamin, Inc., Menlo Park, Calif., 1965 (especially Chapters 4 and 5).
7. M. Spivak, *A Comprehensive Introduction to Differential Geometry*, Vol. I, Publish or Perish, Inc., Boston, 1970.
8. S. Sternberg, *Lectures on Differential Geometry*, Prentice Hall, Englewood Cliffs, N.J., 1964.
9. F. W. Warner, *Foundations of Differentiable Manifolds and Lie Groups*, Scott and Foresman, Glenview, Ill., 1971.
10. H. Whitney, *Geometric Integration Theory*, Princeton University Press, Princeton, N.J., 1957 (especially Chapters II and III).
11. M. L. Curtis and J. Dugundji, A proof of De Rham's theorem, *Fund. Math.* **48** (1970), 265–268.

APPENDIX B

Permutation Groups or Transformation Groups

§1. Basic Definitions

The reader is undoubtedly familiar with the following fact from his previous study of group theory: If E is any set (finite or infinite), then the set of all permutations of E (i.e., function $E \rightarrow E$ which are one-to-one and onto) is a group under the operation of composition or superposition of permutations. He has undoubtedly considered examples of such a group (called the *symmetric* group of the set E), especially in the case where E is a finite set. Also, he has probably studied various subgroups of the symmetric group on a finite set.

If G is an arbitrary group, a homomorphism of G into the symmetric group on a set E is called a *representation of G by permutations of E* . If the homomorphism is an isomorphism, the representation is called *faithful*. It is an easily proved result that any group admits a faithful representation by permutations. We omit the proof because we have no need for this theorem in this book.

We now consider another approach to this same set of ideas which occurs frequently. At first sight, this approach seems quite different, but it leads to the same result.

Definition. Let E be a set and let G be a group. We say that E is a *left G -space* or that E admits G as a *group of operators on the left* if there is given a mapping $G \times E \rightarrow E$, denoted by $(g, x) \rightarrow g \cdot x$ for any $g \in G$ and $x \in E$, such that the following two properties hold:

- (1) For any $x \in E$, $1 \cdot x = x$.
- (2) For any $x \in E$ and $g_1, g_2 \in G$,

$$(g_1 g_2) \cdot x = g_1 \cdot (g_2 \cdot x).$$

For example, if G is a subgroup of the symmetric group of E , and the notation $g \cdot x$ denotes the effect of applying the permutation g to the element $x \in E$, then E is a left G -space.

Another simple example is the following: Let E denote ordinary Euclidean 3-space and let G denote the group of all rotations of E which leave the origin fixed. Let $g \cdot x$ denote the image of the point x under the rotation g . Then E is a left G -space.

Right G -spaces are defined in an analogous fashion. There is assumed given a map $E \times G \rightarrow E$, denoted by $(x, g) \rightarrow x \cdot g$, such that the following two conditions hold:

$$(1') \quad x \cdot 1 = x.$$

$$(2') \quad x \cdot (g_1 g_2) = (x \cdot g_1) \cdot g_2.$$

The essential difference between right and left G -spaces is not whether the elements of G are written on the right or left of those of E . The main point is the difference between condition (2) and condition (2'). If E is a left G -space, then the product $g_1 g_2$ operates on $x \in E$ in such a way that g_2 operates first and then g_1 operates on the result, whereas for right G -spaces, g_1 operates first, then g_2 .

EXERCISES

1.1. Assume that E is a left G -space. For any $x \in E$ and $g \in G$, define

$$x \cdot g = (g^{-1}) \cdot x.$$

With this definition, prove that E is a right G -space.

Theorem 1.1. *Let E be a left- G -space. For any $g \in G$, the map $E \rightarrow E$ defined by $x \rightarrow g \cdot x$ is a permutation of E .*

PROOF. Denote the map in question by $\varphi_g : E \rightarrow E$. Consider the map $\varphi_{g^{-1}}$. It readily follows from the axioms for a left G -space that the composed maps $\varphi_g \varphi_{g^{-1}}$ and $\varphi_{g^{-1}} \varphi_g$ are both the identity maps of E onto itself. Therefore, φ_g is one-to-one and onto, i.e., a permutation. Q.E.D.

This simple but important theorem shows that the notion of a left G -space is equivalent to the notion of a representation of G by permutations of the set E . We must not conclude, however, that such a representation is faithful; it can very well happen that there exists an element $g \neq 1$ in G such that $g \cdot x = x$ for all $x \in E$. In the case where no such element $g \in G$ exists, we say that G operates *effectively* on the set E .

If E_1 and E_2 are left G -spaces, a mapping $f : E_1 \rightarrow E_2$ is called *G -equivariant*, or simply a *mapping of left G -spaces*, in case

$$f(g \cdot x) = g \cdot (fx)$$

for any $g \in G$ and $x \in E_1$. A G -equivariant map $f: E_1 \rightarrow E_2$ is called an *isomorphism of left G -spaces* in case there exists another G -equivariant map $f': E_2 \rightarrow E_1$ such that $f'f$ is the identity map of E_1 and ff' is the identity map of E_2 . This is equivalent to the condition that f be one-to-one and onto. This definition of isomorphism is the natural one in this context. The reader should note that it is sometimes possible for a group G to operate in several different, nonisomorphic ways on a given set E . As usual, an automorphism of a G -space is a self-isomorphism.

§2. Homogeneous G -Spaces

Let E be a left G -space. We say that G operates *transitively* on E or that E is a *homogeneous* left G -space if the following condition holds: For any elements $x, y \in E$, there exists an element $g \in G$ such that

$$g \cdot x = y.$$

Homogeneous G -spaces are of frequent occurrence, and thus are important.

Examples

2.1. Let G be a group, and let H be an arbitrary subgroup of G . We denote by G/H the set of all cosets, $g \cdot H$, $g \in G$. It is readily seen that, if we multiply all the elements in a given coset on the left by any element $g \in G$, we obtain as a result elements all of which lie in the same coset. This defines a map $G \times G/H \rightarrow G/H$, and it is readily verified that the two conditions for a left G -space hold. It is also clear that G/H is a homogeneous left G -space.

We now show that any homogeneous left G -space is isomorphic to some coset space G/H . Let E be an arbitrary homogeneous left G -space. Choose an element $x_0 \in E$, and let

$$H = \{g \in G : g \cdot x_0 = x_0\}.$$

We easily check that H is a subgroup of G . It is called the *isotropy subgroup* corresponding to x_0 . Consider the map $G \rightarrow E$ defined by $g \rightarrow g \cdot x_0$. This map is onto because E is a homogeneous G -space. Under what condition do two elements $g_1, g_2 \in G$ both map onto the same element of E ? This is easily determined as follows:

$$\begin{aligned} g_1 x_0 = g_2 x_0 &\Leftrightarrow g_2^{-1} g_1 x_0 = x_0 \\ &\Leftrightarrow g_2^{-1} g_1 \in H. \end{aligned}$$

Hence, g_1 and g_2 map onto the same element of E if and only if g_1 and g_2 belong to the same coset of H . Therefore, the map $G \rightarrow E$ induces a map $f: G/H \rightarrow E$ which is one-to-one and onto; and it is easily checked that f is

G -equivariant. Thus, G/H and E are isomorphic left G -spaces, as was to be proved.

The isomorphism f and the subgroup H in the preceding argument depend on the choice of the point x_0 in E . A different choice of x_0 will give rise to a conjugate subgroup.

For the purposes of Chapter V, we need to know the structure of the group of automorphisms of a homogeneous G -space. To be consistent with the usage adopted in that chapter, we shall consider a homogeneous *right* G -space E . Let $\varphi : E \rightarrow E$ be an automorphism of E . Then, one verifies directly from the definitions that, for any point $x \in E$, the points x and $\varphi(x)$ have the same isotropy subgroup. Conversely, suppose x and y are points of E which have the same isotropy subgroup. We assert that there exists an automorphism φ of E such that $\varphi(x) = y$. We define φ in the following rather obvious way. Let $z \in E$. Then, there exists a $g \in G$ such that

$$z = x \cdot g.$$

Hence, we must have

$$\varphi(z) = \varphi(x \cdot g) = (\varphi x) \cdot g = y \cdot g.$$

Therefore, we *define* $\varphi(z) = y \cdot g$. Of course, we must check that this definition is independent of the choice of g ; i.e., if $x \cdot g = x \cdot g'$, then $y \cdot g = y \cdot g'$. But this is a consequence of the assumption that x and y have the same isotropy subgroup. We must also verify that the map thus defined is G -equivariant, and that it is one-to-one and onto. It is trivial to verify the first statement, and to verify the second, we construct by the same method an inverse of φ such that $\varphi^{-1}(y) = x$.

Next, we note that if φ_1 and φ_2 are automorphisms of the homogeneous right G -space E , and, for some point $x \in E$, $\varphi_1(x) = \varphi_2(x)$, then $\varphi_1 = \varphi_2$. This is a direct consequence of the fact that G acts transitively on E .

As a consequence of these considerations, we have the following lemma:

Lemma 2.1. *A group A of automorphisms of a homogeneous G -space E is the entire group of automorphisms if and only if for any two points $x, y \in E$ which have the same isotropy subgroup, there exists an automorphism $\varphi \in A$ such that $\varphi(x) = y$.*

Next, we determine the structure of the group of automorphisms of a homogeneous G -space. First, we need a definition. Let H be a subgroup of G and

$$N(H) = \{g \in G : gHg^{-1} = H\}.$$

$N(H)$ is a subgroup of G which contains H , and it is called the *normalizer* of H . It is the largest subgroup of G which contains H as a normal subgroup.

Theorem 2.2. *Let E be a homogeneous G -space, and let H be the isotropy subgroup of G corresponding to the point $x_0 \in E$. Then the group of automorphisms of E is isomorphic to $N(H)/H$.*

PROOF. Let S denote the set of all points $x \in E$ whose isotropy subgroup is H . In view of what we have proved above, we see that the automorphism group acts transitively on S .

Next, we assert that, if $x \in S$ and $g \in G$, then $x \cdot g \in S$ if and only if $g \in N(H)$. For, the condition $xg \in S$ is equivalent to the condition

$$\{h \in G : x \cdot g \cdot h = x \cdot g\} = H.$$

But $xgh = xg$ if and only if $xghg^{-1} = x$, i.e., if and only if $ghg^{-1} \in H$, or $h \in g^{-1}Hg$. Thus, the subgroup $N(H)$ acts transitively on the subspace S , and the elements of H leave each point of S fixed. Hence, the quotient group $N(H)/H$ acts transitively on the right on S without fixed points.

We now set up an isomorphism between the automorphism group and $N(H)/H$ as follows. Let φ be an automorphism; there exists a unique element $\alpha \in N(H)/H$ such that

$$x_0 \cdot \alpha = \varphi(x_0)$$

because $N(H)/H$ operates transitively on S without fixed points. Conversely, for any element $\alpha \in N(H)/H$ there exists a unique automorphism φ such that $\varphi(x_0) = x_0 \cdot \alpha$. Thus, the correspondence $\varphi \leftrightarrow \alpha$ is a one-to-one correspondence between the automorphism group and $N(H)/H$. We now check that this correspondence preserves products, as follows. Suppose that

$$\begin{aligned}\varphi(x_0) &= x_0 \cdot \alpha, \\ \psi(x_0) &= x_0 \cdot \beta.\end{aligned}$$

Then,

$$\begin{aligned}(\varphi\psi)(x_0) &= \varphi(\psi x_0) = \varphi(x_0\beta) \\ &= (\varphi x_0)\beta = (x_0\alpha)\beta = x_0(\alpha\beta);\end{aligned}$$

hence, $\varphi\psi$ and $\alpha\beta$ correspond. Therefore, the correspondence is an isomorphism. Q.E.D.

It should be emphasized that this isomorphism between $N(H)/H$ and the automorphism group is not natural; it depends on the choice of the point $x_0 \in E$. The student should investigate the effect of a different choice of the base point x_0 on the one-to-one correspondence which was set up.

Index

- Acyclic models, method of 288, 298
- Alexander duality theorem 374
- Alexander, J.W. 322, 349, 391
- Algebraic homotopy 167
- Algebraic mapping cone 258–59
- Almost exact sequence 387
- Almost simplicial complex 249
- Anticommutative product 343
- Arc 36
- Augmentation 161, 288
- Automorphisms of a covering space
130, 134–35
- Axiomatic approach to homology
theory 184

- Ball, n -dimensional xv, 188
- Basis for a free group 78
- Betti, E. 156
- Betti group 367
- Betti numbers of a space 224
- Bockstein operator 268, 309
- Borsuk-Ulam theorem 138–40, 397
- Boundaries, group of 160
- Boundary of a cell 239
- Boundary operator 160
of a pair 171
- Boy, W. 33
- Branched covering space 144–45

- Brouwer fixed point theorem 50, 188
- Brouwer, L.E.J. 186, 211

- Cap product 328, 332
in a product space 342–43
- Casson, A. 32
- Cayley projective plane 403
- Čech-Alexander-Spanier cohomology
371
- Čech, E. 322, 349
- Cell, n -dimensional 226
- Cellular map 232
induced homomorphism 236–37
- Chain complex 254
acyclic 288
augmented 265, 288
positive 288
- Chain groups of a CW-complex 233
- Chain homotopy 167, 256
- Chain map 255
- Characteristic map 236
- Classification theorem for compact
surfaces 9, 26
- Coboundaries 307
- Coboundary operator 306
- Cochain
complex 306
homotopy 306

- Cochain (*cont.*)
 map 306
 with compact support 358, 417
 Cocycles 307
 Coefficient homomorphism 267, 309
 Coherent orientations 250
 Cohomology group 307
 Cohomology sequence of a map 401
 Cohomology theory, development of 322
 Cokernel xvi
 Commutator 77
 Compact pair 211
 Complex, CW 228–32
 regular 243–44
 Connected sum 7–9, 32
 Connecting homomorphism 257
 Connectivity
 arcwise or pathwise 36
 local arcwise 36
 semilocal simple 142
 simple 45
 Contractible space 45, 168
 Convex set 46
 Covering space 117–146
 existence theorem for 142–44
 induced over a subspace 122
 of a topological group 129, 135
 Covering transformation 130
 Cross product 325, 330
 Crowell, R.H. 113
 Cup product 325, 331–32, 369
 in a product space 342
 in projective spaces 395–97
 CW-complex 228–232
 Cycles 160
- Defect of singular homology theory 335
 Deformation retract 45, 168
 Degenerate singular cube 159
 Degree of a map 189–190
 DeRham complex 411
 DeRham, G. 417
 DeRham's theorem 413
 Diagonal map 299, 328
 Differentiable singular chains 408
 Differentiable singular cube 408
- Dimension of a CW-complex 229
 Direct limit 359
 Direct product 60–61
 Disc, n -dimensional xv, 188
 Divisible group 311
- Edge of a graph 192
 Eilenberg, S. 184
 Eilenberg-Zilber theorem 284
 Elementary neighborhood 118
 Epimorphism xv
 Equivariant map 420–21
 Euler characteristic
 of a CW-complex 235–36
 of a graph 194
 of a surface 26–30
 Exact homology sequence of a chain map 259
 Exact homology sequence of a pair 171
 Exact sequence xvi
 of chain complexes 257
 Excision property 175
 Excisive couple 301
 Ext functor 311–313
- Face of a cell 243
 Faces of a singular cube 159
 Fibre bundles 145
 Fibre spaces 145
 Five lemma 184
 Fox, R.H. 145
 Free abelian group 63–70
 Free group 75–78
 Free product of groups 71–74
 with amalgamated subgroups 113
 Freedman, M. 32, 114
 Fundamental group 35–41, 86–113
 of a circle 47
 of a compact 4-manifold 114–115
 of a compact surface 96–103
 of the complement of a knot 103–108
 of a connected sum of manifolds 95
 of a covering space 126–27
 of a figure “8” curve 91–92
 of a product space 52–53

- of a punctured disc or plane 92–93
- of real projective n -space 137
- of a topological group 63
- of a union of circles 93
- relation to 1st homology group 217–19

- Generators of a group** 63–64
- Genus of a surface** 30
- Graded module** 344
- Graded ring** 343
- Graph** 192
- Group of a knot** 104
- Group of operators** 419

- Heegard, P.** 156
- History of algebraic topology** 156
- Homogeneous space** 421
 - automorphism group of a 422–23
- Homology group**
 - relative 170, 173–75
 - singular 160
- Homology sequence of a pair** 171
- Homomorphism**
 - induced by a continuous map 42, 163–64
 - of covering spaces 130
- Homotopic maps** 43
- Homotopy** 43
 - classes 166
 - differentiable 409
 - equivalence 57, 168
 - groups of a covering space 145–46
 - type 57, 168
 - type vs. topological type 114
- Hopf, H.** 405
- Hopf invariant** 402–404
- Hurewicz, W.** 58, 185

- Immersion** 32–33
- Incidence numbers** 240, 245, 247–48
- Induced homomorphism** 42, 163–164
- Injective group** 312
- Injective resolution** 313
- Inner product** 310, 324
- Invariance of domain theorem** 216

- Inverse limit** 415
- Isomorphism of groups** xv
- Isotropy subgroup** 421

- Jordan-Brouwer separation theorem** 215
- Jordan curve theorem** 146, 211

- Klein bottle** 7–8
- Knot** 103
- Kolmogoroff, A.N.** 322, 349
- Kunneth theorem** 285

- Lebesgue number** 48, 180
- Lefschetz-Poincaré duality theorem** 377, 379
- Lefschetz, S.** 349, 391–92
- Lifting**
 - of maps 127–29
 - of paths 123–25
- Local arcwise connectivity** 36
- Local homeomorphism** 122
- Local homology group** 191
- Local orientation** 351
- Loop** 41

- Magic formula** 287
- Manifold**
 - definition 2, 350
 - orientable vs. non-orientable 3–5, 352
 - with boundary 375
- Map of pairs** 173
 - homotopic 173–74
- Mapping cone** 399
- Mapping cylinder** 399
- Markov, A.A.** 33, 115
- Mayer-Vietoris sequence** 207–208, 266, 320–21
 - relative 338
 - with compact supports 361–62
- Möbius strip** 3–4
- Moise, E.** 32
- Monomorphism** xv
- Mysterious facts of life** 334

- n-dimensional manifold 2, 350
 - with boundary 375
- Noether, E. 224
- Normalizer of a subgroup 422
- Number of sheets of a covering space 125, 133

- Orientable manifold 3–5, 352
- Orientation of a cell 239, 247–48
- Orientation of a manifold 3, 351
- Orientation of a product complex 281
- Oriented edges 195

- Paths 36
 - closed 41
 - equivalence of 36–37
 - product of 37
- Permutation groups 419–23
- Poincaré, H. 58, 113–14, 156, 391
- Poincaré conjecture 113–14
- Poincaré duality theorem 350, 360, 365
- Poincaré groups 41
- Poincaré series 303
- Pontrjagin, L. 391
- Presentation of a group 78–81
- Product of groups:
 - direct 60–61
 - free 71–74
 - tensor 254
 - weak 61–63
- Projection 118
- Projective group 311
- Projective plane
 - Cayley 403
 - real 6–7
- Projective resolution 313
- Projective spaces 230–32
 - complex 231
 - cup products in 395–97
 - homology groups of 236, 399
 - quaternionic 232
 - real 230–31
- Proper map 359
- Properly discontinuous group 136
- Pseudomanifold 249
 - orientable 251

- Radó, T. 14, 32
- Ramified covering space 144–45
- Rank
 - of an abelian group 235–36
 - of a free abelian group 69
 - of a free group 78
- Reduced cohomology group 308
- Reduced homology group 161
- Reduced word 77
- Regular covering space 134
- Regular CW-complex 243–44
- Relative homology group 169–70
- Retract 44, 166
- Riemann, G.F.B. 156

- Seifert, H. 113
 - theorem of 87–90
- Sheets of a covering space 125, 133
- Simplex, singular 298
- Simplicial complex (see Almost simplicial complex)
- Simplicial singular chains 298
- Singular cube 158
- Singular cycle 155, 160
- Singular homology group 160
- Skeleton of a CW-complex 229
- Skew commutative product 343
- Slant product 327, 330
- Smale, S. 114
- Small of order \mathcal{U} 176
- Sphere, n -dimensional xv, 186
- Split exact sequence 263
- Splitting homomorphism 258, 263
- Steenrod, N.E. 184, 405
- Subcomplex of a CW-complex 232
- Subdivision operator 179, 410
- Support
 - compact 358
 - of a chain 317
 - of a cochain 318–19
 - of a differential form 417
- Surface 5
- Suspension
 - of a map 405
 - of a space 405
- Symmetric group 419

- Taut subspace 370

- Tensor product
 - of chain complexes 282
 - of graded rings 347–48
- Tor functor 270
- Torsion
 - coefficients of a group 70
 - coefficients of a space 224
 - subgroup 70
- Torus 5
 - knot 104–105
- Transformation group 419–23
- Triad 337
 - exact sequence of 337
- Triangulation
 - of a compact surface 14
 - of manifolds 32
- Triple 336
 - exact sequence of 336–37

- Unit n -cube 158

- Universal coefficient theorem
 - for cohomology 314
 - for homology 271–72
- Universal covering space 132
- Universal mapping problems 81–83

- Van der Waerden, B.L. 83
- Van Kampen, E.R. 113
- Van Kampen's theorem 87–90
- Vector field, tangent 189–90
- Vertices of a cube 179
- Vertices of a graph 192

- Weak product of groups 61–63
- Weak topology 226, 229
- Whitehead, J.H.C. 228
- Whitehead, G.W. 405
- Whitney, H. 322, 349

This book is intended to serve as a textbook for a course in algebraic topology at the beginning graduate level. The main topics covered are the classification of compact 2-manifolds, the fundamental group, covering spaces, singular homology theory, and singular cohomology theory. These topics are developed systematically, avoiding all unnecessary definitions, terminology, and technical machinery. Wherever possible, the geometric motivation behind the various concepts is emphasized. The text consists of material from the first five chapters of the author's earlier book, *Algebraic Topology: An Introduction* (GTM 56), together with almost all of the now out-of-print *Singular Homology Theory* (GTM 70). The material from the earlier books has been carefully revised, corrected, and brought up to date.

ISBN 0-387-07430-X
ISBN 3-540-07430-X



听雨尘心@含藏识

免费电子书下载

<http://realking1980.bokee.com>